



# 8Mb (512K x 16) Pseudo Static RAM

## Features

- Wide voltage range: **2.70V–3.30V**
- Access Time: 70ns
- Ultra-low active power
  - **Typical active current: 2.0mA @ f = 1 MHz**
  - **Typical active current: 11mA @ f = f<sub>max</sub>**
- Ultra low standby power
- Easy memory expansion with  $\overline{CE}$ , CE<sub>2</sub>, and  $\overline{OE}$  features
- Automatic power-down when deselected
- CMOS for optimum speed/power
- Offered in a 48 Ball BGA Package

## Functional Description<sup>[1]</sup>

The WCMC8016V9X is a high-performance CMOS pseudo static RAM organized as 512K words by 16 bits that supports an asynchronous memory interface. This device features advanced circuit design to provide ultra-low active current.

This is ideal for providing More Battery Life<sup>®</sup> (MoBL<sup>®</sup>) in portable applications such as cellular telephones. The device can be put into standby mode reducing power consumption by more than 99% when deselected using CE LOW, CE<sub>2</sub> HIGH or both BHE and BLE are HIGH. The input/output pins (I/O<sub>0</sub> through I/O<sub>15</sub>) are placed in a high-impedance state when: deselected (CE HIGH, CE<sub>2</sub> LOW OE is deasserted HIGH), or during a write operation (Chip Enabled and Write Enable WE LOW). The device also has an automatic power-down feature that significantly reduces power consumption by 99% when addresses are not toggling even when the chip is selected (Chip Enable  $\overline{CE}$  LOW, CE<sub>2</sub> HIGH and both BHE and BLE are LOW). Reading from the device is accomplished by asserting the Chip Enables (CE LOW and CE<sub>2</sub> HIGH) and Output Enable (OE) LOW while forcing the Write Enable (WE) HIGH. If Byte Low Enable (BLE) is LOW, then data from the memory location specified by the address pins will appear on I/O<sub>0</sub> to I/O<sub>7</sub>. If Byte High Enable (BHE) is LOW, then data from memory will appear on I/O<sub>8</sub> to I/O<sub>15</sub>. See the Truth Table for a complete description of read and write modes

## Logic Block Diagram

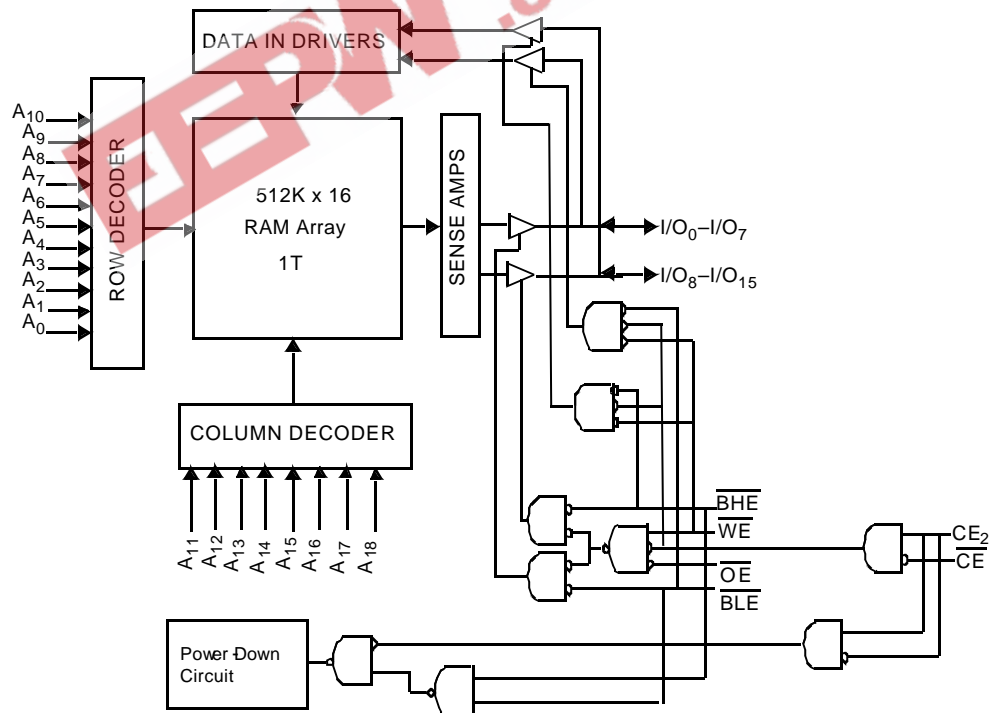

**Note:**

1. For best-practice recommendations, please refer to the Cypress application note "System Design Guidelines" on <http://www.cypress.com>.

**Pin Configuration**<sup>[2, 3, 4]</sup>

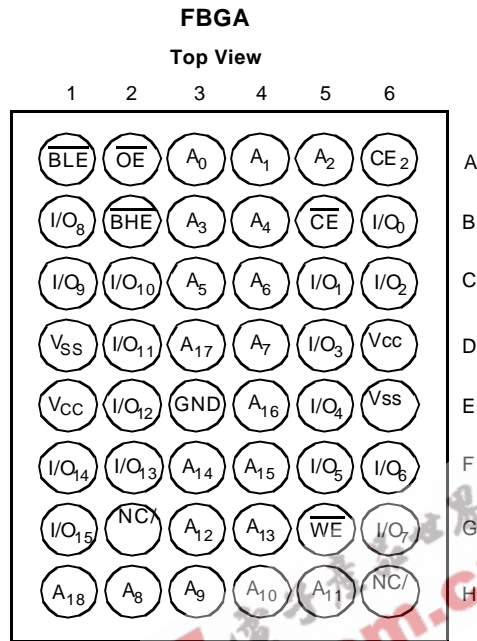

**Note:**

2. NC "no connect" - not connected internally to the die.
3. DNU pins are to be left floating or tied to V<sub>SS</sub>.
4. Ball G2 and H6 are the expansion pins for the 16Mb and 32Mb density resectively.



## ADVANCE INFORMATION

## WCMC8016V9X

### Maximum Ratings

(Above which the useful life may be impaired. For user guidelines, not tested.)

Storage Temperature .....	-65°C to + 150°C
Ambient Temperature with Power Applied .....	-55°C to + 85°C
Supply Voltage to Ground Potential .....	-0.4V to 4.6V

DC Voltage Applied to Outputs in High Z State <sup>[5, 6, 7]</sup> .....	-0.2V to 3.3V
DC Input Voltage <sup>[5, 6, 7]</sup> .....	-0.2V to 3.3V
Output Current into Outputs (LOW).....	20 mA
Static Discharge Voltage .....	>2001V (per MIL-STD-883, Method 3015)
Latch-Up Current .....	>200 mA

### Operating Range<sup>[9]</sup>

Device	Range	Ambient Temperature	V <sub>CC</sub>
WCMC8016V9X	Industrial	-25°C to +85°C	2.70V to 3.30V

### Product Portfolio

Product	V <sub>CC</sub> Range (V)			Speed (ns)	Power Dissipation					
					Operating I <sub>CC</sub> (mA)				Standby I <sub>SB2</sub> (μA)	
					f = 1MHz		f = f <sub>max</sub>			
Min.	Typ. <sup>[8]</sup>	Max.	Typ. <sup>[8]</sup>	Max.	Typ. <sup>[8]</sup>	Max.	Typ. <sup>[8]</sup>	Max.		
WCMC8016V9X-FI70	2.70	3.0	3.30	70	2	3.5	11	17	55	80

**Notes:**

5. V<sub>IH(MAX)</sub> = V<sub>CC</sub> + 0.5V for pulse durations less than 20ns.
6. V<sub>IL(MIN)</sub> = -0.5V for pulse durations less than 20ns.
7. Overshoot and undershoot specifications are characterized and are not 100% tested.
8. Typical values are included for reference only and are not guaranteed or tested. Typical values are measured at V<sub>CC</sub> = V<sub>CC</sub> (typ) and T<sub>A</sub> = 25°C
9. V<sub>CC</sub> must be at minimal operational levels before inputs are turned ON.

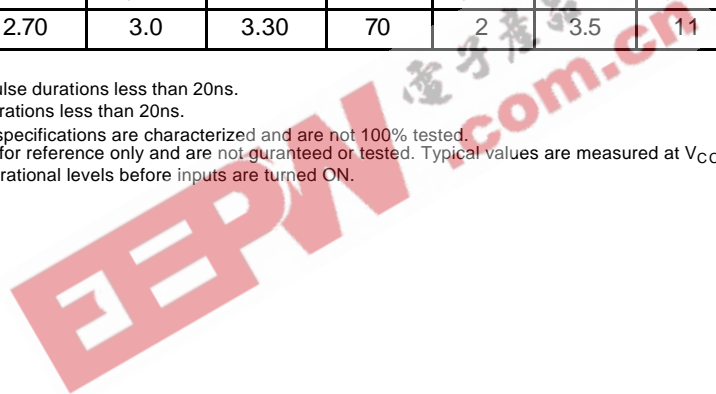



**Electrical Characteristics** Over the Operating Range

Parameter	Description	Test Conditions	WCMC8016V9X-70			Unit
			Min.	Typ. <sup>[8]</sup>	Max.	
V <sub>CC</sub>	Supply Voltage		2.7		3.3	V
V <sub>OH</sub>	Output HIGH Voltage	I <sub>OH</sub> = -1.0 mA V <sub>CC</sub> = 2.70V	2.4			V
V <sub>OL</sub>	Output LOW Voltage	I <sub>OL</sub> = 2.0mA V <sub>CC</sub> = 2.70V			0.4	V
V <sub>IH</sub>	Input HIGH Voltage	V <sub>CC</sub> = 2.7V to 3.3V	0.8*V <sub>CC</sub>		V <sub>CC</sub> +0.3V	V
V <sub>IL</sub>	Input LOW Voltage	V <sub>CC</sub> = 2.7V to 3.3V(F = 0)	-0.3		0.4	V
I <sub>IX</sub>	Input Leakage Current	GND ≤ V <sub>I</sub> ≤ V <sub>CC</sub>	-1		+1	μA
I <sub>OZ</sub>	Output Leakage Current	GND ≤ V <sub>O</sub> ≤ V <sub>CC</sub> , Output Disabled	-1		+1	μA
I <sub>CC</sub>	V <sub>CC</sub> Operating Supply Current	f = f <sub>MAX</sub> = 1/t <sub>RC</sub> f = 1 MHz		11	17	mA
		V <sub>CC</sub> = V <sub>CCmax</sub> I <sub>OUT</sub> = 0 mA CMOS levels		2.0	3.5	mA
I <sub>SB1</sub>	Automatic $\overline{CE}$ Power-Down Current — CMOS Inputs	$\overline{CE} \geq V_{CC} - 0.2V$ or $CE_2 \leq 0.2V$ $V_{IN} \geq V_{CC} - 0.2V$ , $V_{IN} \leq 0.2V$ f = f <sub>MAX</sub> (Address and Data Only) f = 0 ( $\overline{OE}$ , $\overline{WE}$ , $\overline{BHE}$ and $\overline{BLE}$ ), V <sub>CC</sub> = 3.30V			400	μA
I <sub>SB2</sub>	Automatic CE Power-Down Current — CMOS Inputs	CE ≥ V <sub>CC</sub> - 0.2V or CE <sub>2</sub> ≤ 0.2V, V <sub>IN</sub> ≥ V <sub>CC</sub> - 0.2V or V <sub>IN</sub> ≤ 0.2V, f = 0, V <sub>CC</sub> = 3.30V	V <sub>CC</sub> = 3.3V	55	80	μA
			V <sub>CC</sub> = 3.0V	50	70	μA
			V <sub>CC</sub> = 2.8V	45	60	μA

**Capacitance<sup>[10]</sup>**

Parameter	Description	Test Conditions	Max.	Unit
C <sub>IN</sub>	Input Capacitance	T <sub>A</sub> = 25°C, f = 1 MHz, V <sub>CC</sub> = V <sub>CC(typ)</sub>	6	pF
C <sub>OUT</sub>	Output Capacitance		8	pF

**Thermal Resistance<sup>[10]</sup>**

Description	Test Conditions	Symbol	BGA	Unit
Thermal Resistance (Junction to Ambient)	Still Air, soldered on a 3 × 4.5 inch, two-layer printed circuit board	θ <sub>JA</sub>	55	°C/W
Thermal Resistance (Junction to Case)		θ <sub>JC</sub>	16	°C/W

**Note:**

10. Tested initially and after any design or process changes that may affect these parameters.

**AC Test Loads and Waveforms**

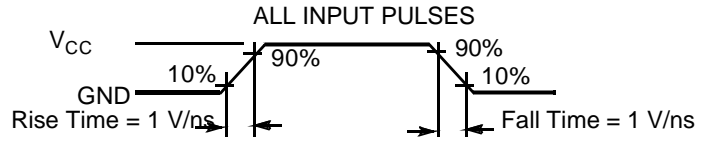
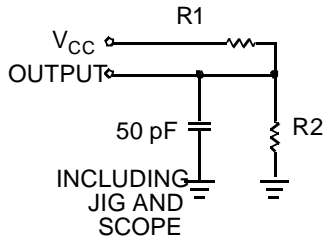

Equivalent to: THEVENINEQUIVALENT

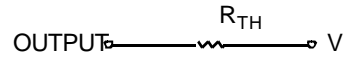

Parameters	3.0V V <sub>CC</sub>	Unit
R1	1179	Ω
R2	1941	Ω
R <sub>TH</sub>	733	Ω
V <sub>TH</sub>	1.87	V

EEPW 电子产品世界 .com.cn



Switching Characteristics Over the Operating Range<sup>[11]</sup>

Parameter	Description	70 ns		Unit
		Min.	Max.	
<b>READ CYCLE</b>				
t <sub>RC</sub>	Read Cycle Time	70		ns
t <sub>AA</sub>	Address to Data Valid		70	ns
t <sub>OHA</sub>	Data Hold from Address Change	10		ns
t <sub>ACE</sub>	CE LOW and CE <sub>2</sub> HIGH to Data Valid		70	ns
t <sub>DOE</sub>	OE LOW to Data Valid		35	ns
t <sub>LZOE</sub>	OE LOW to Low Z <sup>[12, 14]</sup>	5		ns
t <sub>HZOE</sub>	OE HIGH to High Z <sup>[12, 14]</sup>		25	ns
t <sub>LZCE</sub>	CE LOW and CE <sub>2</sub> HIGH to Low Z <sup>[12, 14]</sup>	5		ns
t <sub>HZCE</sub>	CE HIGH and CE <sub>2</sub> LOW to High Z <sup>[12, 14]</sup>		25	ns
t <sub>DBE</sub>	BLE / BHE LOW to Data Valid		70	ns
t <sub>LZBE</sub>	BLE / BHE LOW to Low Z <sup>[12, 14]</sup>	5		ns
t <sub>HZBE</sub>	BLE / BHE HIGH to High Z <sup>[12, 14]</sup>		25	ns
t <sub>SK</sub>	Address Skew		10	ns
<b>WRITE CYCLE<sup>[13]</sup></b>				
t <sub>WC</sub>	Write Cycle Time	70		ns
t <sub>SCE</sub>	CE LOW and CE <sub>2</sub> HIGH to Write End	60		ns
t <sub>AW</sub>	Address Set-Up to Write End	60		ns
t <sub>HA</sub>	Address Hold from Write End	0		ns
t <sub>SA</sub>	Address Set-Up to Write Start	0		ns
t <sub>PWE</sub>	WE Pulse Width	45		ns
t <sub>BW</sub>	BLE / BHE LOW to Write End	60		ns
t <sub>SD</sub>	Data Set-Up to Write End	45		ns
t <sub>HD</sub>	Data Hold from Write End	0		ns
t <sub>HZWE</sub>	WE LOW to High-Z <sup>[12, 14]</sup>		25	ns
t <sub>LZWE</sub>	WE HIGH to Low-Z <sup>[12, 14]</sup>	5		ns

Notes:

11. Test conditions for all parameters other than tri-state parameters assume signal transition time of 1ns/V, timing reference levels of V<sub>CC(typ)</sub>/2, input pulse levels of 0 to V<sub>CC(typ)</sub>, and output loading of the specified I<sub>OL</sub>/I<sub>OH</sub> as shown in the "AC Test Loads and Waveforms" section.
12. t<sub>LZOE</sub>, t<sub>HZOE</sub>, t<sub>LZBE</sub>, and t<sub>HZBE</sub> transitions are measured when the outputs enter a high impedance state.
13. The internal Write time of the memory is defined by the overlap of WE, CE = V<sub>IL</sub>, BHE and/or BLE = V<sub>IL</sub>, and CE<sub>2</sub> = V<sub>IH</sub>. All signals must be ACTIVE to initiate a write and any of these signals can terminate a write by going INACTIVE. The data input set-up and hold timing should be referenced to the edge of the signal that terminates the write.
14. High-Z and Low-Z parameters are characterized and are not 100% tested.

**Switching Waveforms**

**Read Cycle 1 (Address Transition Controlled)<sup>[15]</sup>**

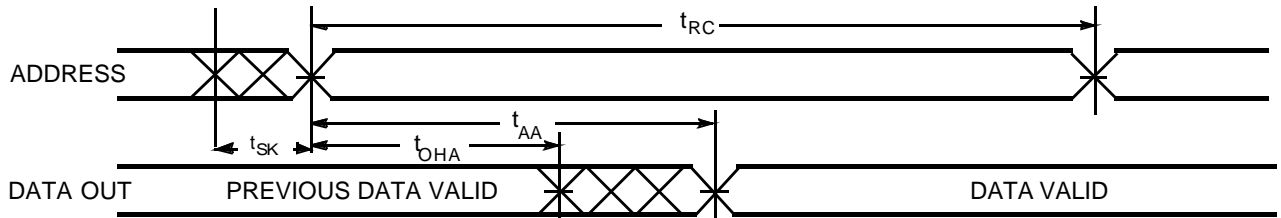

**Read Cycle 2 ( $\overline{OE}$  Controlled)<sup>[15]</sup>**

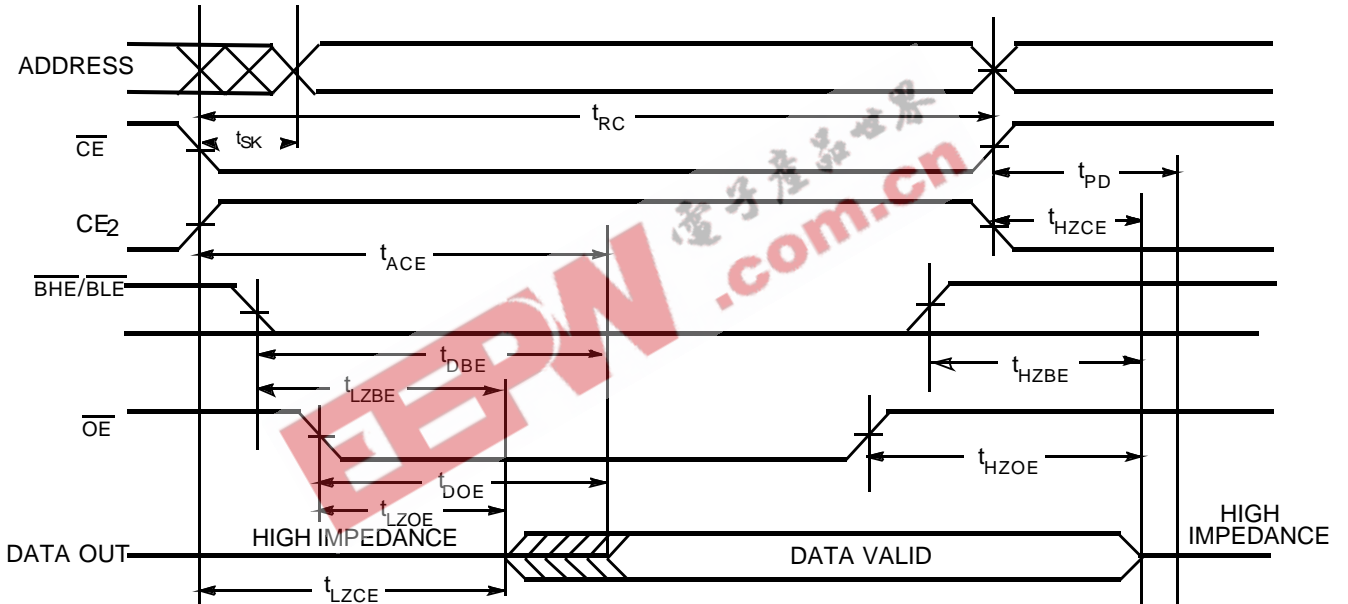

**Note:**  
15.  $\overline{WE}$  is HIGH for read cycle.

Switching Waveforms (continued)

Write Cycle 1 ( $\overline{WE}$  Controlled) [13, 14, 16, 17, 18]

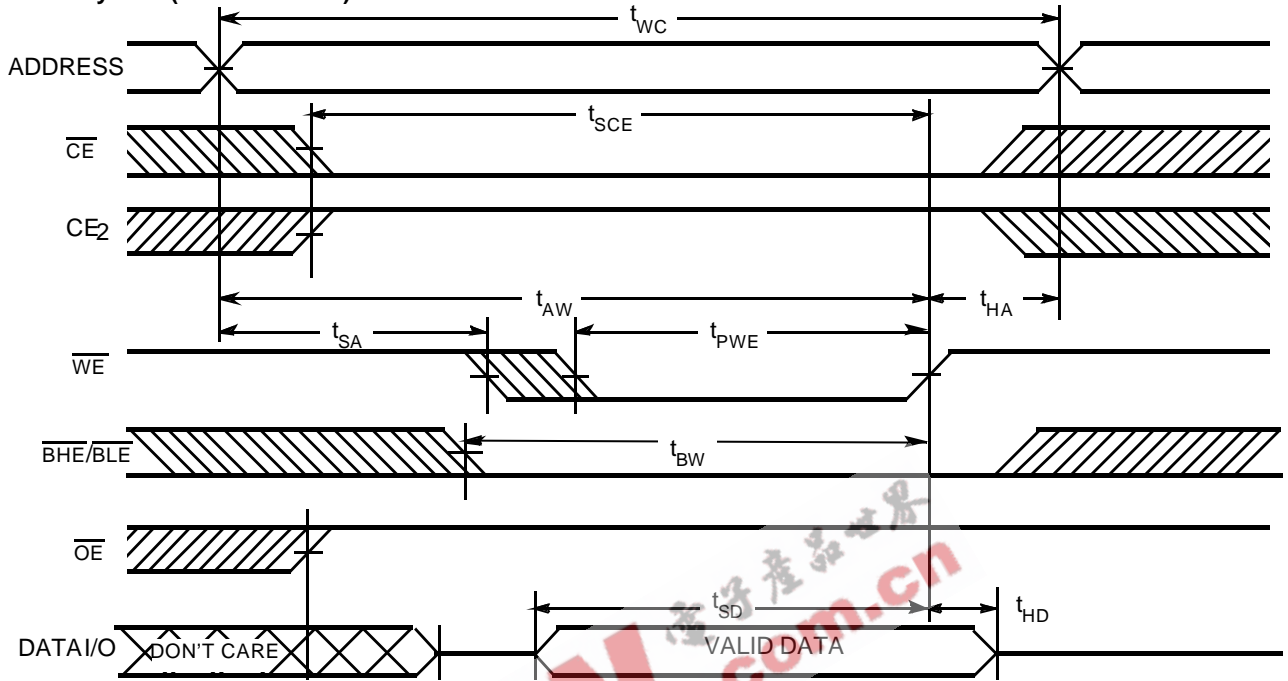

Write Cycle 2 ( $\overline{CE}$  or  $CE_2$  Controlled) [13, 14, 16, 17, 18]

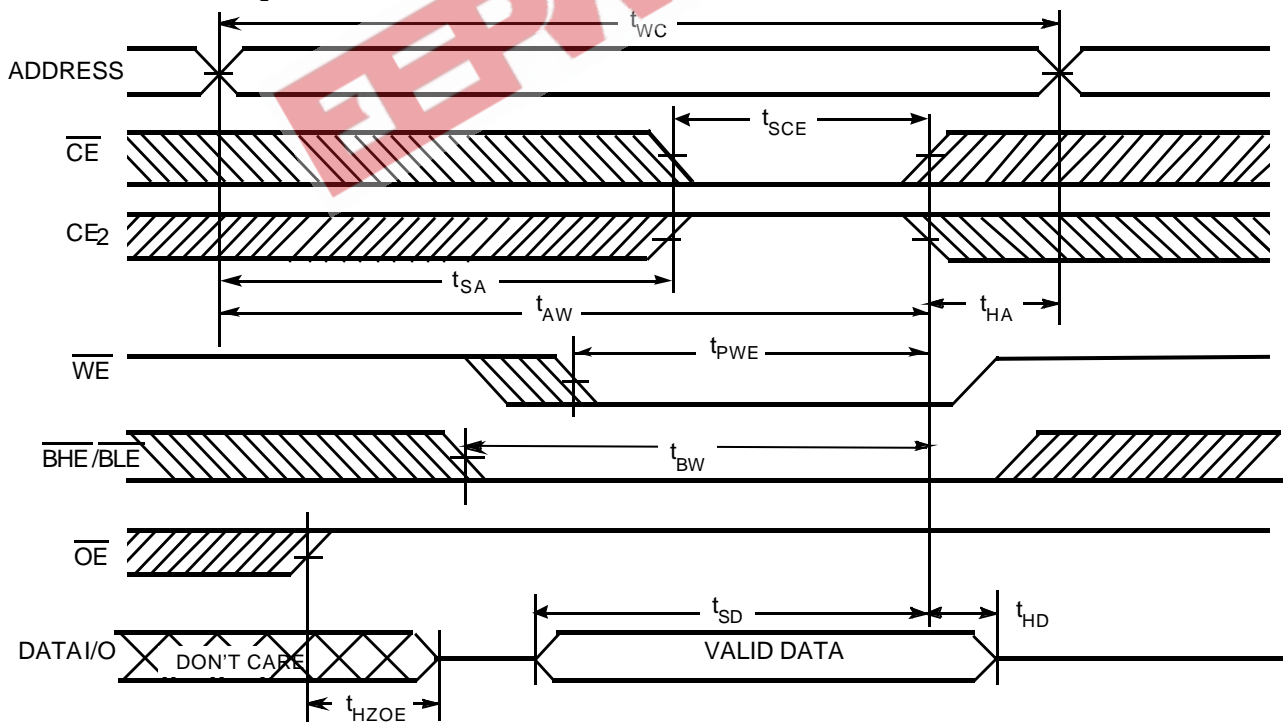

Notes:

- 16. Data I/O is high impedance if  $\overline{OE} = V_{IH}$ .
- 17. If Chip Enable goes INACTIVE and  $CE_2$  goes LOW simultaneously with  $\overline{WE} = V_{IH}$ , the output remains in a high-impedance state.
- 18. During the DON'T CARE period in the DATA I/O waveform, the I/Os are in output state and input signals should not be applied.



**Switching Waveforms (continued)**

**Write Cycle 3 (WE Controlled, OE LOW)<sup>[17, 18]</sup>**

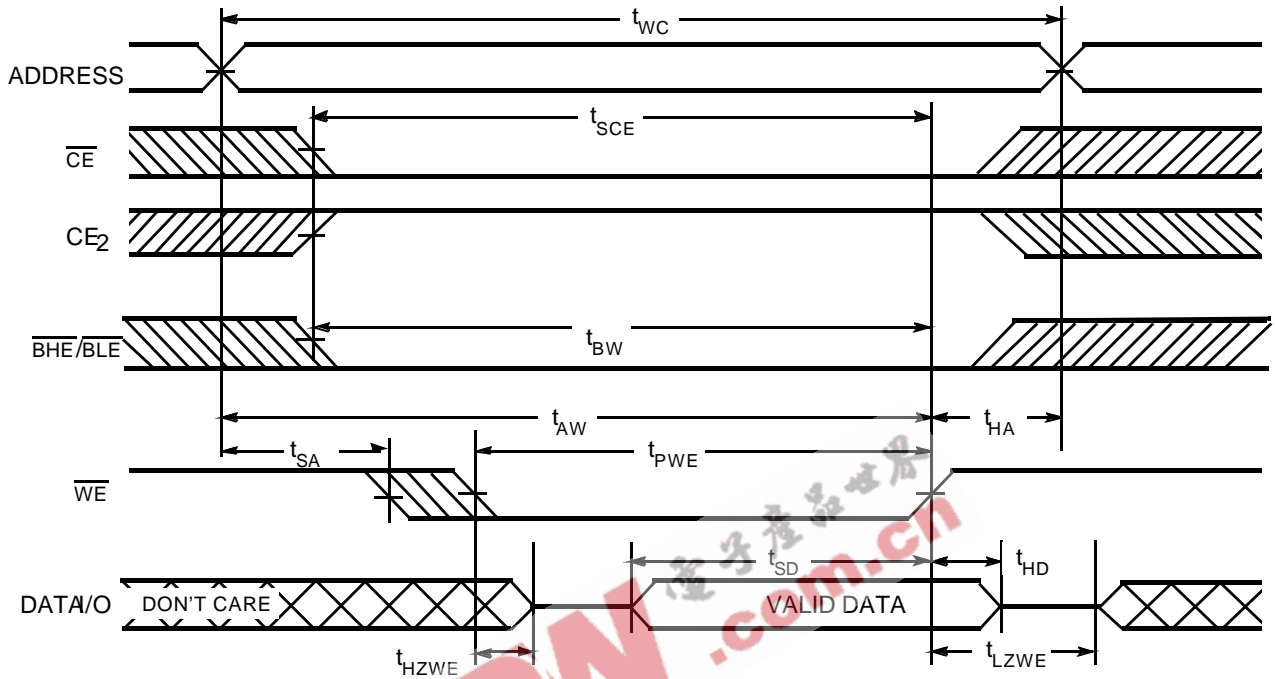

**Write Cycle 4 (BHE/BLER Controlled, OE LOW)<sup>[17, 18]</sup>**

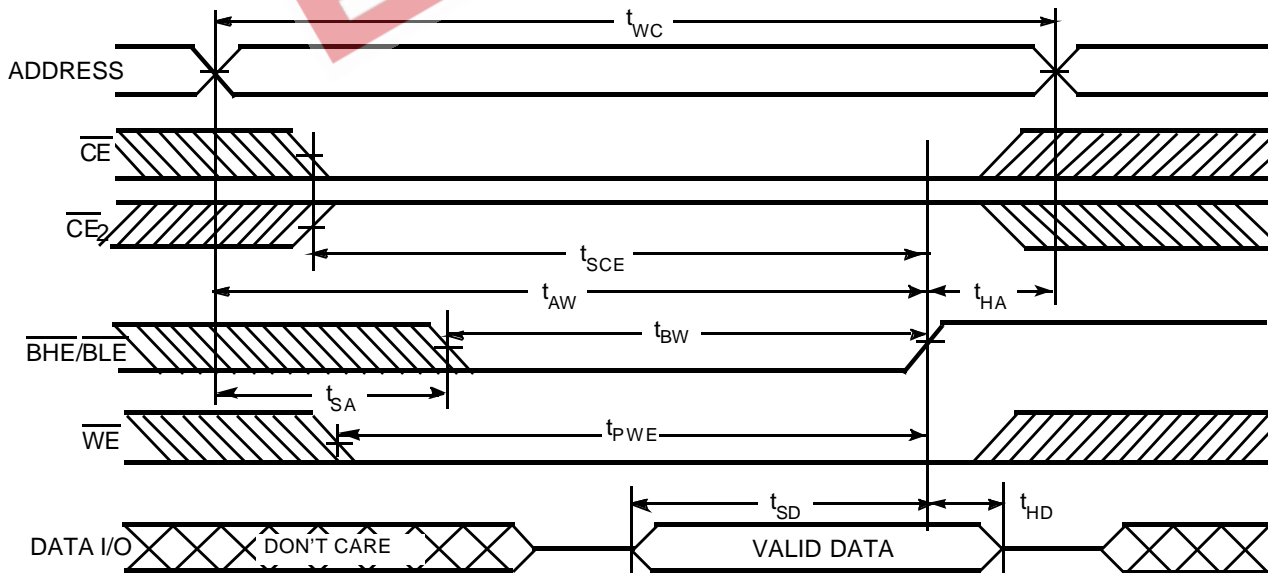



**Truth Table<sup>[19]</sup>**

$\overline{CE}$	$CE_2$	$\overline{WE}$	$\overline{OE}$	$\overline{BHE}$	$\overline{BLE}$	Inputs/Outputs	Mode	Power
H	X	X	X	X	X	High Z	Deselect/Power-Down	Standby ( $I_{SB}$ )
X	L	X	X	X	X	High Z	Deselect/Power-Down	Standby ( $I_{SB}$ )
X	X	X	X	H	H	High Z	Deselect/Power-Down	Standby ( $I_{SB}$ )
L	H	H	L	L	L	Data Out (I/O0 – I/O15)	Read	Active ( $I_{CC}$ )
L	H	H	L	H	L	Data Out (I/O0 – I/O7); High Z (I/O8 – I/O15)	Read	Active ( $I_{CC}$ )
L	H	H	L	L	H	High Z (I/O0 – I/O7); Data Out (I/O8 – I/O15)	Read	Active ( $I_{CC}$ )
L	H	H	H	L	H	High Z	Output Disabled	Active ( $I_{CC}$ )
L	H	H	H	H	L	High Z	Output Disabled	Active ( $I_{CC}$ )
L	H	H	H	L	L	High Z	Output Disabled	Active ( $I_{CC}$ )
L	H	L	X	L	L	Data In (I/O0 – I/O15)	Write	Active ( $I_{CC}$ )
L	H	L	X	H	L	Data In (I/O0 – I/O7); High Z (I/O8 – I/O15)	Write	Active ( $I_{CC}$ )
L	H	L	X	L	H	High Z (I/O0 – I/O7); Data In (I/O8 – I/O15)	Write	Active ( $I_{CC}$ )

Note:

19. H =  $V_{IH}$ , L =  $V_{IL}$ , X = Don't Care

**Ordering Information**

Speed (ns)	Ordering Code	Package Name	Package Type	Operating Range
70	WCMC8016V9X-FI70	BA48K	48-ball Fine Pitch BGA (6 mm × 8mm × 1.2 mm)	Industrial

Package

48-Ball (6 mm x 8mm x 1.2 mm) FBGA BA48K

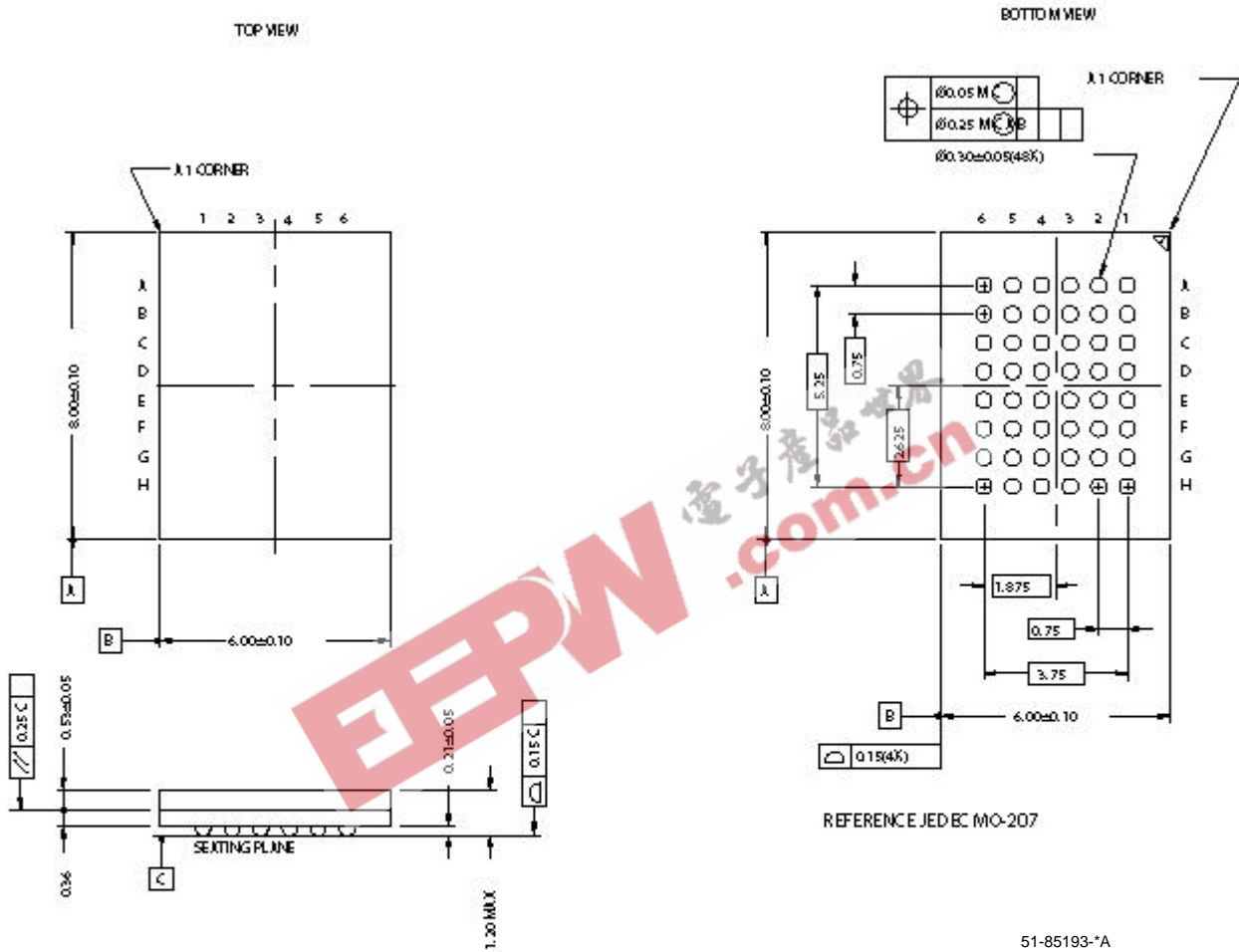

MoBL and More Battery Life are trademarks of Cypress Semiconductor Corporation. All product and company names mentioned in this document may be the trademarks of their respective holders



**ADVANCE INFORMATION**

**WCMC8016V9X**

<b>Document Title: WCMC8016V9X MoBL3<sup>®</sup> 8Mb (512K x 16) Pseudo Static RAM</b> <b>Document Number: 38-14026</b>				
<b>REV.</b>	<b>ECN NO.</b>	<b>Issue Date</b>	<b>Orig. of Change</b>	<b>Description of Change</b>
**	130543	10/16/03	MPR	New Datasheet

**EEPW** 电子產品世界  
**.com.cn**