



256MB- 32Mx64 SDRAM UNBUFFERED

FEATURES

- PC100 and PC133 compatible
- Burst Mode Operation
- Auto and Self Refresh capability
- LVTTTL compatible inputs and outputs
- Serial Presence Detect with EEPROM
- Fully synchronous: All signals are registered on the positive edge of the system clock
- Programmable Burst Lengths: 1, 2, 4, 8 or Full Page
- 3.3V ± 0.3V Power Supply
- 168 pin DIMM JEDEC

DESCRIPTION

The W3DG6432V is a 32Mx64 synchronous DRAM module which consists of eight 16Mx16 SDRAM components in TSOP II package and one 2K EEPROM in an 8 pin TSSOP package for Serial Presence Detect which are mounted on a 168 pin DIMM multilayer FR4 Substrate.

PIN CONFIGURATIONS (FRONT SIDE/BACK SIDE)

Pin	Front	Pin	Front	Pin	Front	Pin	Back	Pin	Back	Pin	Back
1	Vss	29	DQM1	57	DQ18	85	Vss	113	DQM5	141	DQ50
2	DQ0	30	CS0#	58	DQ19	86	DQ32	114	CS1#	142	DQ51
3	DQ1	31	DNU	59	Vcc	87	DQ33	115	RAS#	143	Vcc
4	DQ2	32	Vss	60	DQ20	88	DQ34	116	Vss	144	DQ52
5	DQ3	33	A0	61	NC	89	DQ35	117	A1	145	NC
6	Vcc	34	A2	62	NC	90	Vcc	118	A3	146	NC
7	DQ4	35	A4	63	CKE1	91	DQ36	119	A5	147	DNU
8	DQ5	36	A6	64	Vss	92	DQ37	120	A7	148	Vss
9	DQ6	37	A8	65	DQ21	93	DQ38	121	A9	149	DQ53
10	DQ7	38	A10/AP	66	DQ22	94	DQ39	122	BA0	150	DQ54
11	DQ8	39	BA1	67	DQ23	95	DQ40	123	A11	151	DQ55
12	Vss	40	Vcc	68	Vss	96	Vss	124	Vcc	152	Vss
13	DQ9	41	Vcc	69	DQ24	97	DQ41	125	NC	153	DQ56
14	DQ10	42	CK0	70	DQ25	98	DQ42	126	A12	154	DQ57
15	DQ11	43	Vss	71	DQ26	99	DQ43	127	Vss	155	DQ58
16	DQ12	44	DNU	72	DQ27	100	DQ44	128	CKE0	156	DQ59
17	DQ13	45	CS2#	73	Vcc	101	DQ45	129	CS3#	157	Vcc
18	Vcc	46	DQM2	74	DQ28	102	Vcc	130	DQM6	158	DQ60
19	DQ14	47	DQM3	75	DQ29	103	DQ46	131	DQM7	159	DQ61
20	DQ15	48	DNU	76	DQ30	104	DQ47	132	NC	160	DQ62
21	NC	49	Vcc	77	DQ31	105	NC	133	Vcc	161	DQ63
22	NC	50	NC	78	Vss	106	NC	134	NC	162	Vss
23	Vss	51	NC	79	CK2	107	Vss	135	NC	163	NC
24	NC	52	NC	80	NC	108	NC	136	NC	164	NC
25	NC	53	NC	81	*WP	109	NC	137	NC	165	**SA0
26	Vcc	54	Vss	82	**SDA	110	Vcc	138	Vss	166	**SA1
27	WE#	55	DQ16	83	**SCL	111	CAS#	139	DQ48	167	**SA2
28	DQM0	56	DQ17	84	Vcc	112	DQM4	140	DQ49	168	Vcc

PIN NAMES

A0 – A12	Address input (Multiplexed)
BA0-1	Select Bank
DQ0-63	Data Input/Output
CK0,CK2	Clock input
CKE0,CKE1	Clock Enable input
CS0#-CS3#	Chip select Input
RAS#	Row Address Strobe
CAS#	Column Address Strobe
WE#	Write Enable
DQM0-7	DQM
Vcc	Power Supply (3.3V)
Vss	Ground
SDA	Serial data I/O
SCL	Serial clock
DNU	Do not use
NC	No Connect

* WP (write protect) option available on pin 81, see ordering information on page 5.
 ** These pins should be NC in the system which does not support SPD.



FUNCTIONAL BLOCK DIAGRAM

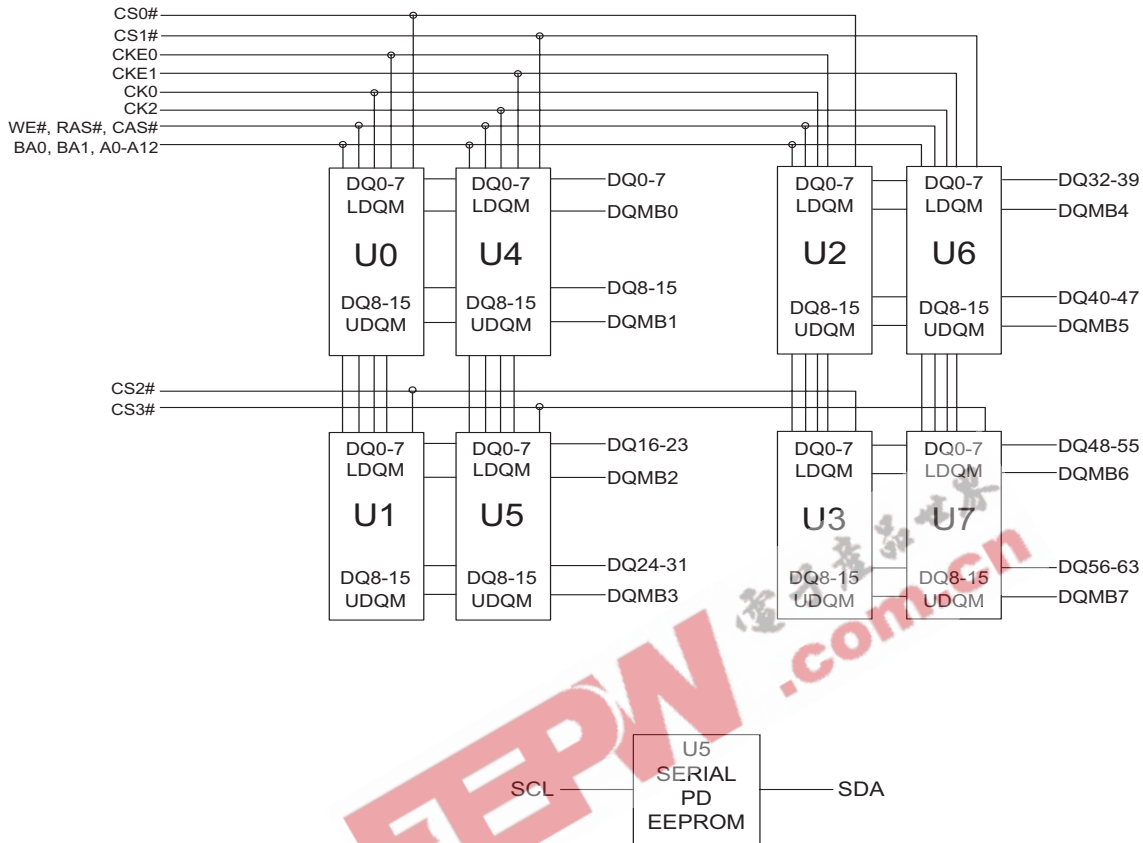



Absolute Maximum Ratings

Parameter	Symbol	Value	Units
Voltage on any pin relative to V _{ss}	V _{IN} , V _{OUT}	-1.0 ~ 4.6	V
Voltage on V _{cc} supply relative to V _{ss}	V _{cc} , V _{ccq}	-1.0 ~ 4.6	V
Storage Temperature	T _{STG}	-55 ~ +150	°C
Power Dissipation	P _D	8	W
Short Circuit Current	I _{OS}	50	mA

Note: Permanent device damage may occur if "ABSOLUTE MAXIMUM RATINGS" are exceeded.
 Functional operation should be restricted to recommended operating condition.
 Exposure to higher than recommended voltage for extended periods of time could affect device reliability.

RECOMMENDED DC OPERATING CONDITIONS

(Voltage Referenced to: V_{ss} = 0V, 0°C ≤ T_A ≤ 70°C)

Parameter	Symbol	Min	Typ	Max	Unit	Note
Supply Voltage	V _{cc}	3.0	3.3	3.6	V	
Input High Voltage	V _{IH}	2.0	3.0	V _{ccq} +0.3	V	1
Input Low Voltage	V _{IL}	-0.3	—	0.8	V	2
Output High Voltage	V _{OH}	2.4	—	—	V	I _{OH} = -2mA
Output Low Voltage	V _{OL}	—	—	0.4	V	I _{OL} = -2mA
Input Leakage Current	I _{LI}	-10	—	10	A	3

Note: 1. V_{IH} (max) = 5.6V AC. The overshoot voltage duration is ≤ 3ns.
 2. V_{IL} (min) = -2.0V AC. The undershoot voltage duration is ≤ 3ns.
 3. Any input 0V ≤ V_{IN} ≤ V_{ccq}
 Input leakage currents include Hi-Z output leakage for all bi-directional buffers with Tri-State outputs.

Capacitance

(T_A = 23°C, f = 1MHz, V_{cc} = 3.3V, V_{REF} = 1.4V ± 200mV)

Parameter	Symbol	Min	Max	Unit
Input Capacitance (A0-A12)	C _{IN1}	-	45	pF
Input Capacitance (RAS#,CAS#,WE#)	C _{IN2}	-	45	pF
Input Capacitance (CKE0)	C _{IN3}	-	25	pF
Input Capacitance (CK0,CK2)	C _{IN4}	-	13	pF
Input Capacitance (CS0#,CS2#)	C _{IN5}	-	15	pF
Input Capacitance (DQM0-DQM7)	C _{IN6}	-	10	pF
Input Capacitance (BA0-BA1)	C _{IN7}	-	45	pF
Data input/output capacitance (DQ0-DQ63)	C _{OUT}	-	12	pF



OPERATING CURRENT CHARACTERISTICS
($V_{CC} = 3.3V, 0^{\circ}C \leq T_A \leq 70^{\circ}C$)

Parameters	Symbol	Conditions	Versions		Units	Note
			133	100		
Operating Current (One bank active)	I _{CC1}	Burst Length = 1 $t_{RC} \geq t_{RC(min)}$ $I_{OL} = 0mA$	740	700	mA	1
Precharge Standby Current in Power Down Mode	I _{CC2P}	$CKE \leq V_{IL(max)}, t_{CC} = 10ns$	20		mA	
	I _{CC2PS}	$CKE \& CK \leq V_{IL(max)}, t_{CC} = \infty$	20		mA	
Precharge Standby Current in Non-Power Down Mode	I _{CC2N}	$CKE \geq V_{IH(min)}, CS \geq V_{IH(min)}, t_{CC} = 10ns$ Input signals are charged one time during 20	130		mA	
	I _{CC2NS}	$CKE \geq V_{IH(min)}, CK \leq V_{IL(max)}, t_{CC} = \infty$ Input signals are stable	115		mA	
Active standby current in power- down mode	I _{CC3P}	$CKE \geq V_{IL(max)}, t_{CC} = 10ns$	50		mA	
	I _{CC3PS}	$CKE \& CK \leq V_{IL(max)}, t_{CC} = \infty$	50			
Active standby in current non power-down mode	I _{CC3N}	$CKE \geq V_{IH(min)}, CS \geq V_{IH(min)}, t_{CC} = 10ns$ Input signals are charged one time during 20ns	280		mA	
	I _{CC3NS}	$CKE \geq V_{IH(min)}, CK \leq V_{IL(max)}, t_{CC} = \infty$ input signals are stable	240		mA	
Operating current (Burst mode)	I _{CC4}	$I_O = mA$ Page burst 4 Banks activated $t_{CCD} = 2CK$	860	720	mA	1
Refresh current	I _{CC5}	$t_{RC} \geq t_{RC(min)}$	980	940	mA	2
Self refresh current	I _{CC6}	$CKE \leq 0.2V$	40		mA	

Notes: 1. Measured with outputs open.
2. Refresh period is 64ms.
3. Unless otherwise noticed, input swing level is CMOS ($V_{IH}/V_{IL} = V_{CC}/V_{SS0}$)



ORDERING INFORMATION

Part Number	Speed	CAS Latency
W3DG6432V10D2	100MHz	CL=2
W3DG6432V7D2	133MHz	CL=2
W3DG6432V75D2	133MHz	CL=3

Note: Modules are available in industrial temperature - 40°C to 85°C. Add an "I" to the end of the part number.

Part Number	Speed	CAS Latency
WED3DG6332V10D2	100MHz	CL=2
WED3DG6332V7D2	133MHz	CL=2
WED3DG6332V75D2	133MHz	CL=3

Note: Available with WP (write protect) on pin 81.

PACKAGE DIMENSIONS

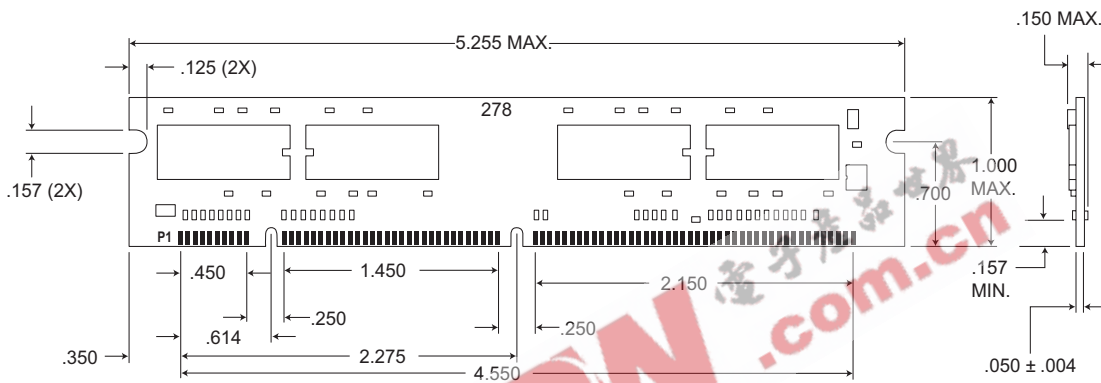

ALL DIMENSIONS ARE IN INCHES