

## W91590 SERIES



# 24-MEMORY TONE/PULSE SWITCHABLE DIALER WITH HANDFREE, HOLD AND LOCK FUNCTIONS

## GENERAL DESCRIPTION

The W91590 series dialers Si-gate CMOS IC tone/pulse switchable dialers with a 24-channel automatic dialing memory, including a 16-digit  $\times$  3 emergency dialing memory, a 16-digit  $\times$  20 channel repertory memory that provides one-touch and three-touch dialing, and a 32-digit mercury memory. These dialers also provide flash, clear, hold, and one-key redial functions.

## FEATURES

- DTMF/Pulse switchable dialer
- 32-digit LNB (last number buffer) memory (both tone and pulse mode)
- 32-digit mercury memory (tone/pulse mode)
- 16-digit  $\times$  3 one-touch direct repertory memory (tone/pulse mode)
- 16-digit  $\times$  20 direct or indirect repertory memory (tone/pulse mode)
- Uses 9  $\times$  5 keyboard
- Flash time: 98 mS, 305 mS, or 600 mS (selectable by keypad option)
- Pause time: 3.6 sec.
- Pause P $\rightarrow$ T (pulse-to-tone) can be stored as a digit in memory
- Minimum tone output duration: 93 mS
- Minimum intertone pause: 93 mS
- On-chip power-on reset
- Uses 3.579545 MHz crystal or ceramic resonator
- Packaged in 22, 24 or 28-pin plastic DIP
- The different dialers in the W91590 series are shown in the following table:

TYPE NO.	PULSE (ppS)	MEMORY	MERCURY MEMORY	HOLD	HANDFREE	LOCK FUNCTION	PACKAGE
W91590	10	20	-	-	-	-	22
W91590L	10	20	-	-	-	Yes	22
W91590A	10	20	-	-	Yes	-	24
W91590AL	10	20	-	-	Yes	Yes	24
W91590B	10/20	24	Yes	Yes	Yes	-	28
W91590BL	10/20	24	Yes	Yes	Yes	Yes	28
W91590C	10/20	24	Save Memory	Yes	Yes	-	28
W91590CL	10/20	24	Save Memory	Yes	Yes	Yes	28

# W91590 SERIES



## PIN CONFIGURATIONS

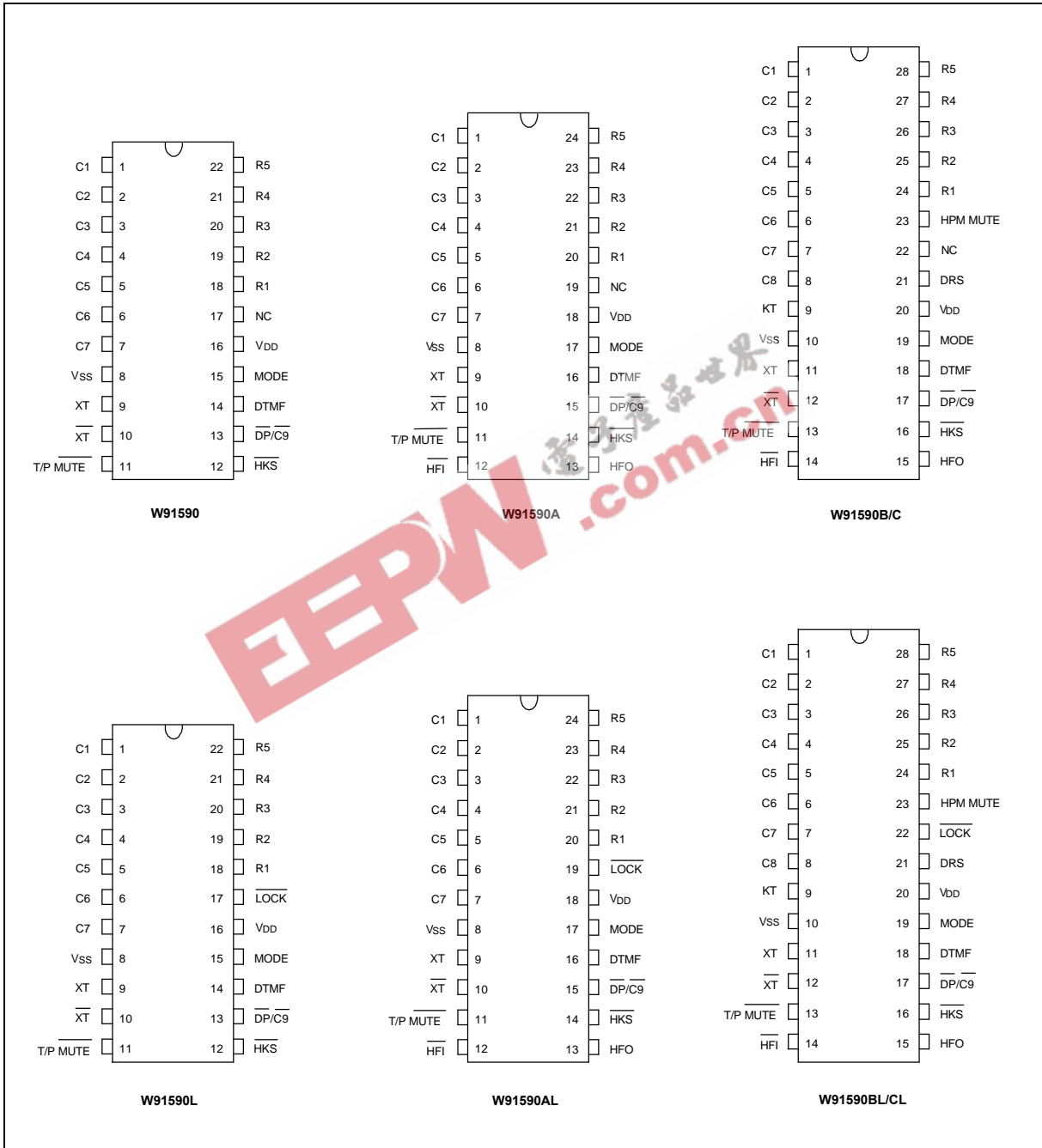

# W91590 SERIES



## PIN DESCRIPTION

SYMBOL	22-PIN	24-PIN	28-PIN	I/O	FUNCTION
Column-Row Inputs	1-7 & 18-22	1-7 & 20-24	1-8 & 24-28	I	The keyboard input may be from either the standard 9 × 5 keyboard or an inexpensive single contact (form A) keyboard. Electronic input from a $\mu$ C can also be used. A valid key entry is defined by a single row being connected to a single column.
XT, $\overline{\text{XT}}$	9, 10	9, 10	11, 12	I, O	A built-in inverter provides oscillation with an inexpensive 3.579545 MHz crystal or ceramic resonator.
$\overline{\text{T/P MUTE}}$	11	11	13	O	The $\overline{\text{T/P MUTE}}$ is a conventional CMOS N-channel open drain output. The output transistor is switched on during pulse and tone mode dialing sequence and flash break. Otherwise, it is switched off.
HPM MUTE	-	-	23	O	The HPM MUTE is a conventional inverter output. During pulse dialing, flash, hold, and mercury mute functions, this pin will output an active high. It remains in a low state at all other times.
MODE	15	17	19	I	Pulling mode pin to V <sub>SS</sub> places the dialer in tone mode. Pulling mode pin to V <sub>DD</sub> places the dialer in pulse mode (M/B = 2:3). Leaving mode pin floating places the dialer in pulse mode (M/B = 1:2).
$\overline{\text{HKS}}$	12	14	16	I	Hook switch input. $\overline{\text{HKS}} = 1$ : On-hook state. Chip in sleeping mode, no operation. $\overline{\text{HKS}} = 0$ : Off-hook state. Chip enabled for normal operation. $\overline{\text{HKS}}$ pin is pulled to V <sub>DD</sub> by internal resistor.
$\overline{\text{DP/C9}}$	13	15	17	O	N-channel open drain dialing pulse output (Figure 1). Flash key causes $\overline{\text{DP}}$ to go active when in pulse mode and tone mode.
NC	17 (W91590)	19 (W91590A)	22 (W91590B/C)	-	No connection.

# W91590 SERIES



Pin Description, continued

SYMBOL	22-PIN	24-PIN	28-PIN	I/O	FUNCTION																																								
$\overline{\text{LOCK}}$	17 (For W91590L)	19 (For W91590AL)	22 (For W91590BL/CL)	I	<p>The function of this pin is as follows:</p> <table border="1"> <thead> <tr> <th><math>\overline{\text{LOCK}}</math> PIN</th> <th>FUNCTION</th> </tr> </thead> <tbody> <tr> <td>V<sub>DD</sub></td> <td>"0", "9" dialing inhibited</td> </tr> <tr> <td>Floating</td> <td>Normal dialing</td> </tr> <tr> <td>V<sub>SS</sub></td> <td>"0" dialing inhibited</td> </tr> </tbody> </table>	$\overline{\text{LOCK}}$ PIN	FUNCTION	V <sub>DD</sub>	"0", "9" dialing inhibited	Floating	Normal dialing	V <sub>SS</sub>	"0" dialing inhibited																																
$\overline{\text{LOCK}}$ PIN	FUNCTION																																												
V <sub>DD</sub>	"0", "9" dialing inhibited																																												
Floating	Normal dialing																																												
V <sub>SS</sub>	"0" dialing inhibited																																												
DTMF	14	16	18	O	<p>In pulse mode, remains in low state at all times. In tone mode, outputs a dual or single tone. Detailed timing diagram for tone mode is shown in Figure 2.</p> <table border="1"> <thead> <tr> <th colspan="4">OUTPUT FREQUENCY</th> </tr> <tr> <th></th> <th>Specified</th> <th>Actual</th> <th>Error%</th> </tr> </thead> <tbody> <tr> <td>R1</td> <td>697</td> <td>699</td> <td>+0.28</td> </tr> <tr> <td>R2</td> <td>770</td> <td>766</td> <td>-0.52</td> </tr> <tr> <td>R3</td> <td>852</td> <td>848</td> <td>-0.47</td> </tr> <tr> <td>R4</td> <td>941</td> <td>948</td> <td>+0.74</td> </tr> <tr> <td>C1</td> <td>1209</td> <td>1216</td> <td>+0.57</td> </tr> <tr> <td>C2</td> <td>1336</td> <td>1332</td> <td>-0.30</td> </tr> <tr> <td>C3</td> <td>1477</td> <td>1472</td> <td>-0.34</td> </tr> </tbody> </table>	OUTPUT FREQUENCY					Specified	Actual	Error%	R1	697	699	+0.28	R2	770	766	-0.52	R3	852	848	-0.47	R4	941	948	+0.74	C1	1209	1216	+0.57	C2	1336	1332	-0.30	C3	1477	1472	-0.34				
OUTPUT FREQUENCY																																													
	Specified	Actual	Error%																																										
R1	697	699	+0.28																																										
R2	770	766	-0.52																																										
R3	852	848	-0.47																																										
R4	941	948	+0.74																																										
C1	1209	1216	+0.57																																										
C2	1336	1332	-0.30																																										
C3	1477	1472	-0.34																																										
V <sub>DD</sub> , V <sub>SS</sub>	16, 8	18, 8	20, 10	I	Power input pins.																																								
HFI, HFO	-	12, 13	14, 15	I, O	<p>Handfree control pins. A low pulse on the HFI input pin toggles the handfree control state. Status of the handfree control state is listed in the following table:</p> <table border="1"> <thead> <tr> <th colspan="2">CURRENT STATE</th> <th colspan="3">NEXT STATE</th> </tr> <tr> <th>Hook SW.</th> <th>HFO</th> <th>Input</th> <th>HFO</th> <th>Dialing</th> </tr> </thead> <tbody> <tr> <td>-</td> <td>Low</td> <td><math>\overline{\text{HFI}} \downarrow</math></td> <td>High</td> <td>Yes</td> </tr> <tr> <td>On Hook</td> <td>High</td> <td><math>\overline{\text{HFI}} \downarrow</math></td> <td>Low</td> <td>No</td> </tr> <tr> <td>Off Hook</td> <td>High</td> <td><math>\overline{\text{HFI}} \downarrow</math></td> <td>Low</td> <td>Yes</td> </tr> <tr> <td>On Hook</td> <td>-</td> <td>Off Hook</td> <td>Low</td> <td>Yes</td> </tr> <tr> <td>Off Hook</td> <td>Low</td> <td>On Hook</td> <td>Low</td> <td>No</td> </tr> <tr> <td>Off Hook</td> <td>High</td> <td>On Hook</td> <td>High</td> <td>Yes</td> </tr> </tbody> </table> <p>HFI pin is pulled to V<sub>DD</sub> by internal resistor. The detailed timing is shown in Fig 3.</p>	CURRENT STATE		NEXT STATE			Hook SW.	HFO	Input	HFO	Dialing	-	Low	$\overline{\text{HFI}} \downarrow$	High	Yes	On Hook	High	$\overline{\text{HFI}} \downarrow$	Low	No	Off Hook	High	$\overline{\text{HFI}} \downarrow$	Low	Yes	On Hook	-	Off Hook	Low	Yes	Off Hook	Low	On Hook	Low	No	Off Hook	High	On Hook	High	Yes
CURRENT STATE		NEXT STATE																																											
Hook SW.	HFO	Input	HFO	Dialing																																									
-	Low	$\overline{\text{HFI}} \downarrow$	High	Yes																																									
On Hook	High	$\overline{\text{HFI}} \downarrow$	Low	No																																									
Off Hook	High	$\overline{\text{HFI}} \downarrow$	Low	Yes																																									
On Hook	-	Off Hook	Low	Yes																																									
Off Hook	Low	On Hook	Low	No																																									
Off Hook	High	On Hook	High	Yes																																									
KT	-	-	9	O	<p>Key tone signal output. A key tone will be generated whenever a valid keys is pressed. Frequency is 600 Hz and duration is 35 mS.</p>																																								

# W91590 SERIES



Pin Description, continued

SYMBOL	22-PIN	24-PIN	28-PIN	I/O	FUNCTION																															
DRS	-	-	21	I	<p>Dial rate selection. This pin is pulled to V<sub>DD</sub> by an internal resistor.</p> <table border="1"> <thead> <tr> <th>DRS</th> <th>MODE PIN</th> <th>TONE/PULSE</th> <th>DIAL RATE</th> <th>M/B</th> </tr> </thead> <tbody> <tr> <td rowspan="3">1</td> <td>V<sub>DD</sub></td> <td>Pulse</td> <td>10 ppS</td> <td>2:3</td> </tr> <tr> <td>Floating</td> <td>Pulse</td> <td>10 ppS</td> <td>1:2</td> </tr> <tr> <td>V<sub>SS</sub></td> <td>Tone</td> <td>—</td> <td>—</td> </tr> <tr> <td rowspan="3">2</td> <td>V<sub>DD</sub></td> <td>Pulse</td> <td>10 ppS</td> <td>1:2</td> </tr> <tr> <td>Floating</td> <td>Pulse</td> <td>20 ppS</td> <td>1:2</td> </tr> <tr> <td>V<sub>SS</sub></td> <td>Tone</td> <td>—</td> <td>—</td> </tr> </tbody> </table>	DRS	MODE PIN	TONE/PULSE	DIAL RATE	M/B	1	V <sub>DD</sub>	Pulse	10 ppS	2:3	Floating	Pulse	10 ppS	1:2	V <sub>SS</sub>	Tone	—	—	2	V <sub>DD</sub>	Pulse	10 ppS	1:2	Floating	Pulse	20 ppS	1:2	V <sub>SS</sub>	Tone	—	—
DRS	MODE PIN	TONE/PULSE	DIAL RATE	M/B																																
1	V <sub>DD</sub>	Pulse	10 ppS	2:3																																
	Floating	Pulse	10 ppS	1:2																																
	V <sub>SS</sub>	Tone	—	—																																
2	V <sub>DD</sub>	Pulse	10 ppS	1:2																																
	Floating	Pulse	20 ppS	1:2																																
	V <sub>SS</sub>	Tone	—	—																																

## BLOCK DIAGRAM

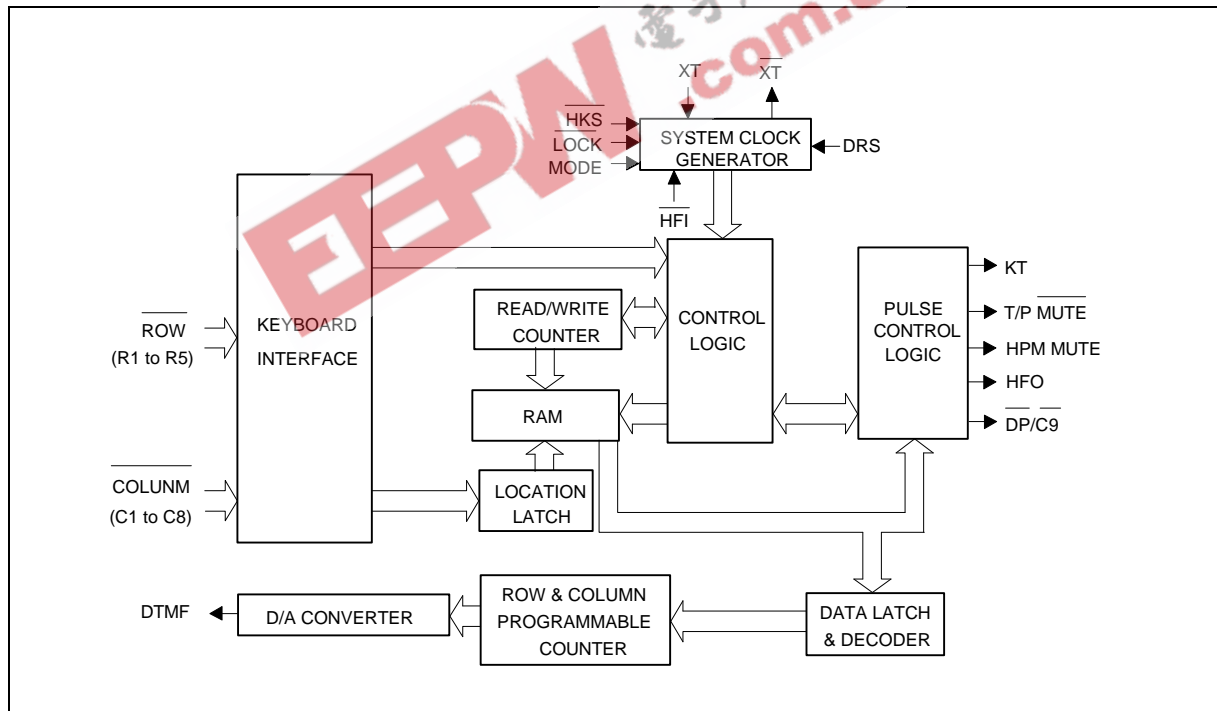

# W91590 SERIES



## FUNCTIONAL DESCRIPTION

### Keyboard Operation

C1	C2	C3	C4	C5	C6	C7	$\overline{DP/C9}$	C8	
1	2	3	S	M00	M05	M10	M15	EM1	R1
4	5	6	MEMO	M01	M06	M11	M16	EM2	R2
7	8	9	CLR	M02	M07	M12	M17	EM3	R3
*/T	0	#	R/P	M03	M08	M13	M18	H	R4
F1	F2	F3	R	M04	M09	M14	M19	*MER	R5

**MER** location in W91590C/CL is SAVE memory.

- S: Store function key
- F1, F2, F3: Flash keys
- R: One-key redial
- H: Hold function key
- $\overline{C9}$ : This key is connected to pin  $\overline{DP/C9}$  via a bipolar switching transistor and a diode
- M0j: Direct or indirect (MEMO + M0j = M1j) repertory memory
- M1j: Direct repertory dialing
- EMi: One-touch memory for emergency call
- \*/T: \* & P→T
- CLR: Clear key
- R/P: Redial and pause function key
- MER: One-touch memory for mercury code dialing
- MEMO: Indirect repertory dialing function key

Note: Dn = 0 to 9, \*, #, Mij = M00 to M19 (i = 0, 1; j = 0 to 9).

### Normal Dialing

**OFF HOOK** (or **ON HOOK** &  **$\overline{HFI}$** ), **D1**, **D2**, ..., **Dn**

1. D1, D2, ..., Dn will be dialed out.
2. Dialing length is unlimited, but redial is inhibited if length oversteps 32 digits.



## Redialing

- OFF HOOK , D1 , D2 , ..., Dn BUSY, Come ON HOOK , OFF HOOK  
 (or ON HOOK &  $\overline{\text{HFI}} \downarrow$  ), R/P  
 or ON HOOK &  $\overline{\text{HFI}} \downarrow$  , D1 , D2 , ..., Dn , BUSY,  $\overline{\text{HFI}} \downarrow$  Come  
 $\overline{\text{HFI}} \downarrow$  , R/P

The R/P key can execute redial function only as first key-in after off-hook. Otherwise, it will execute pause function.

- OFF HOOK (or ON HOOK &  $\overline{\text{HFI}} \downarrow$  ), D1 , D2 , ..., Dn , R

  - The one-key redial function timing diagram is shown in Figure 4.
  - If dialing D1 to Dn is completed, pressing the R key will cause the pulse output of pin to go low for 2.2 seconds. Break time and a 600 mS pause will automatically be added.
  - If the pulses of the dialed D1 to Dn have not finished, R will be ignored.

## Number Store

- OFF HOOK (or ON HOOK &  $\overline{\text{HFI}} \downarrow$  ), S , D1 , D2 , ..., Dn  
 S , Mij , EMi or MER

D1, D2, ..., Dn will be stored in memory location but will not be dialed out.

R/P and \*/T keys can be stored as a digit in memory. In store mode, R/P is the pause function key.

The store mode can be released after the store function is executed or the state of the hook switch is changed.

- S , D1 , D2 , ..., Dn , S , i , j

D1, D2, ..., Dn will be stored in memory location Mij and will not be dialed out.

- S , D1 , D2 , ..., Dn , S , MEMO , M0j

a. D1, D2, ..., Dn will be stored in memory location M10 to M19 and will not be dialed out.

b. MEMO + M0j = M1j.

# W91590 SERIES



4.  (or  &  ),  ,  , ...,  ,  ,  ,  or

- a. D1, D2, ..., Dn will be stored in memory location and will be dialed out.
- b. The  key must be pressed after completion of the dialing sequence.

5.  ,  , ...,  ,  ,  ,  ,

D1, D2, ..., Dn will be stored in memory location Mij and will be dialed out.

6.  ,  , ...,  ,  ,  ,  ,

- a. D1, D2, ..., Dn will be stored in memory location M10 to M19 and will be dialed out.
- b. MEMO + M0j = M1j.

## Repertory Dialing

1.  (or  &  ),  or  or
2.  (or  &  ),  ,  ,
3.  (or  &  ),  ,

## Access Pause

- (or  &  ),  ,  ,  ,  , ...,

1. The pause function can be stored in memory.
2. The pause function is executed in normal dialing, redialing, or memory dialing.
3. The pause function timing diagram is shown in Figure 5.

## Pulse-to-Tone (\* / T)

- (or  &  ),  ,  , ...,  ,

- ,  ,  , ...,

1. If the mode switch is set to pulse mode, then the output signal will be:  
 D1, D2, ..., Dn, Pause (3.6s), D1', D2', ..., Dn'  
 (Pulse) (Tone)
2. If the mode switch is set to tone mode, then the output signal will be:  
 D1, D2, ..., Dn, \* , D1', D2', ..., Dn'  
 (Tone) (Tone) (Tone)



## W91590 SERIES



3. The dialer remains in tone mode when the digits have been dialed out and can be reset to pulse mode only by going on-hook.
4. The P→T function timing diagram is shown in Figure 6.
5. \*/ T key can be stored as a digit in memory

### Flash (F = F1, F2, F3)

OFF HOOK (or  ON HOOK &   $\overline{\text{HFI}}\downarrow$ ),  F

1. Flash key cannot be stored as a digit in memory, and has first priority among keyboard functions.
2. The system will return to the initial state after the break time is finished.
3. The flash function timing diagram is shown in Figure 7.

### Clear key

1.  CLR,  R/P (or  R)

Redial and one-key redial buffer will be cleared.

2.  CLR,  Mij

Location Mij buffer content will be cleared.

3.  CLR,  i,  j

Location Mij buffer content will be cleared.

4.  CLR,  MEMO,  MOj

Location Mij buffer content will be cleared.

### Save

1.  OFF HOOK (or  ON HOOK &   $\overline{\text{HFI}}\downarrow$ ), D1, D2, ..., Dn,  S,  S,  SAVE

D1, D2, ..., Dn will be stored in save memory and dialed out.

2.  OFF HOOK (or  ON HOOK &   $\overline{\text{HFI}}\downarrow$ ),  SAVE

D1, D2, ..., Dn will be stored in save memory but will not be dialed out.

3.  OFF HOOK (or  ON HOOK &   $\overline{\text{HFI}}\downarrow$ ), D1, D2, ..., Dn,  S,  S,  SAVE

D1, D2, ..., Dn will be stored in save memory and dialed out.



## CHAIN DIALING

Relationship between the memory and the chain dialing buffer:

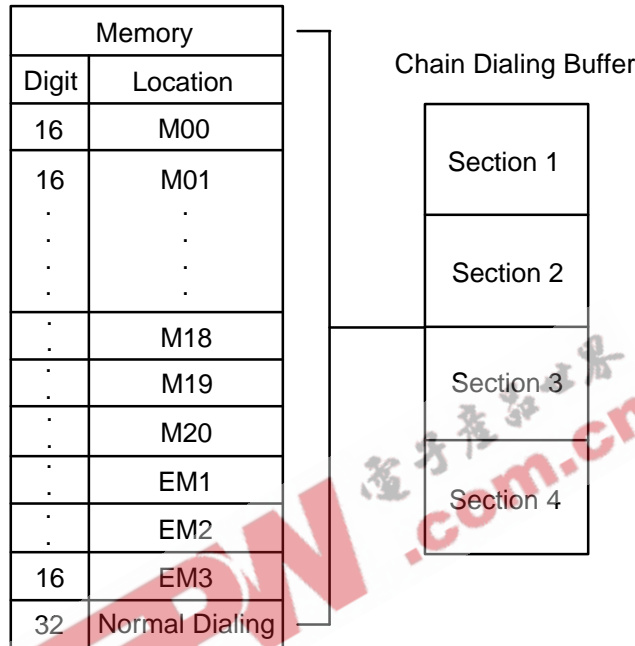

The chain dialing buffer may be divided into four sections, allowing up to four numbers to be dialed out in sequence. For example, if the user enters M01, M03, EM1, and normal dialing (manual dialing), the content of sections 1 to 4 will be M01, M03, EM1, and normal dialing (manual dialing). When numbers are entered into the chain dialing buffer, there is no need to wait until the previous dialing sequence has been completed. Numbers may be entered directly, one after the other, even while previous numbers are being dialed out.

1. Manual Dialing + Repertory Dialing  
Redial buffer content = Manual dialing + Repertory dialing
2. Repertory Dialing + Manual Dialing  
Redial buffer content = Repertory dialing + Manual dialing
3. Repertory Dialing + Repertory Dialing  
Redial buffer content = Repertory dialing + Repertory dialing
4. Redialing + Manual Dialing  
Redial buffer content = Redialing + Manual dialing

The primary redial content may not be manual dialing, or else the last redial content will be overwritten.

5. Redialing + Repertory Dialing

# W91590 SERIES



Redial buffer content = Redialing + Repertory dialing

Redialing is valid only as the first key-in after off-hook or after the handfree dialing function is toggled on.

The second sequence should not be performed until the first sequence is completely dialed out.

6.  +

Redial buffer content = Manual dialing

The One-key redial may only be used after dialing out of a manual dialing sequence is completed.

7.  +  +  
 +

or

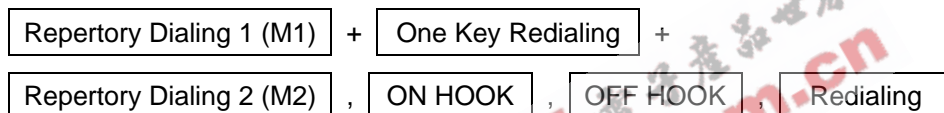

M1 and M2 represent any of the repertory dialing memories.

The first redialing will dial out M1; the second will dial out M1, M2.

If dialing out of the repertory dialing memories has not been completed, the one-key redial key will be ignored.

Dialing of the second repertory dialing memory (M2) should not be performed until the one-key redialing operation is completed.

## Notes:

1. Chain dialing (cascaded dialing) allows for memory or manual dialing while a previous dialing sequence is still being dialed out.
2. More than one sequence of manual dialing is not permitted.  
Entering more than one manual dialing sequence will inhibit redialing.  
Chain dialing of more than four sections is not permitted.

+  +  (two sections of manual dialing)

3. If more than four sections are entered, all sections after the fourth section will be ignored and redialing will be inhibited.

+  +  +  +  (over 4 sections, ignore  and inhibit redial)

4. There is a 2.0 sec. inter-chain dialing pause for cascaded dialing.



## MERCURY DIALING

1. Up to 32 digits may be stored.
2. Mercury dialing is activated only as the first key-in after off-hook or handfree dialing is activated.
3. The timing diagram for the mercury memory function is given below.

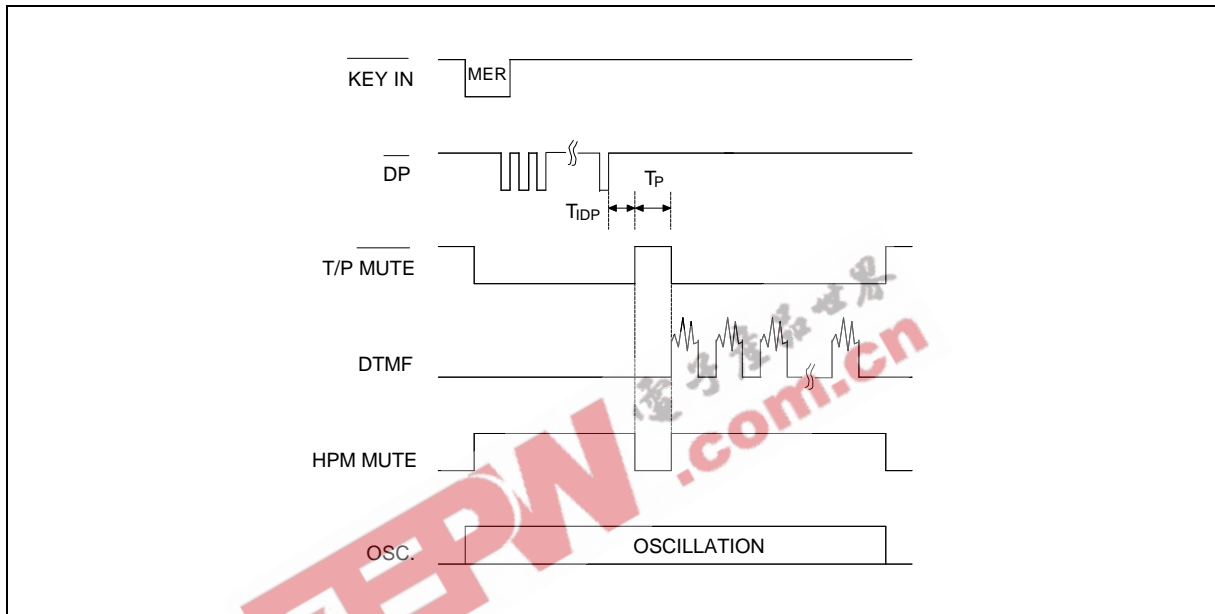

Mercury Function Timing Diagram

## ABSOLUTE MAXIMUM RATINGS

PARAMETER	SYMBOL	RATING	UNIT
DC Supply Voltage	VDD-VSS	-0.3 to +7.0	V
Input/Output Voltage	VIL	VSS -0.3	V
	VIH	VDD +0.3	V
	VOL	VSS -0.3	V
	VOH	VDD +0.3	V
Power Dissipation	PD	120	mW
Operating Temperature	TOPR	-20 to +70	°C
Storage Temperature	TSTG	-55 to +125	°C

Note: Exposure to conditions beyond those listed under Absolute Maximum Ratings may adversely affect the life and reliability of the device.

# W91590 SERIES



## DC CHARACTERISTICS

(V<sub>DD</sub>-V<sub>SS</sub> = 2.5V, F<sub>osc</sub> = 3.58 MHz, T<sub>a</sub> = 25° C, all outputs unloaded)

PARAMETER	SYM.	CONDITIONS	MIN.	TYP.	MAX.	UNIT
Operating Voltage	V <sub>DD</sub>		2.0	-	5.5	V
Operating Current	I <sub>OP</sub>	Tone	-	0.3	0.5	mA
		Pulse	-	0.15	0.3	
Standby Current	I <sub>SB</sub>	$\overline{\text{HKS}} = 0$ , No load & No key entry	-	-	15	μA
Memory Retention Current	I <sub>MR</sub>	$\overline{\text{HKS}} = 1$ , V <sub>DD</sub> = 1.0V	-	-	0.2	μA
DTMF Output Voltage	V <sub>TO</sub>	Row group, R <sub>L</sub> = 5K	130	150	170	V <sub>rmS</sub>
Pre-emphasis	-	Col/Row, V <sub>DD</sub> = 2.0 to 5.5V	1	2	3	dB
DTMF Distortion	THD	R <sub>L</sub> = 5 KΩ, V <sub>DD</sub> = 2.0 to 5.5V	-	-30	-23	dB
DTMF Output DC Level	V <sub>TDC</sub>	R <sub>L</sub> = 5 KΩ, V <sub>DD</sub> = 2.0 to 5.5V	1.0	-	3.0	V
DTMF Output Sink Current	I <sub>TL</sub>	V <sub>TO</sub> = 0.5V	0.2	-	-	mA
$\overline{\text{DP}}$ Output Sink Current	I <sub>PL</sub>	V <sub>PO</sub> = 0.5V	0.5	-	-	mA
T/P $\overline{\text{MUTE}}$ Output Sink Current	I <sub>ML</sub>	V <sub>MO</sub> = 0.5V	0.5	-	-	mA
HPM MUTE Output Sink Current	I <sub>HPML</sub>	V <sub>TO</sub> = 0.5V	0.5	-	-	mA
HPM MUTE Output drive Current	I <sub>HPMH</sub>	V <sub>TH</sub> = 2.0V	0.5	-	-	mA
$\overline{\text{HKS}}$ I/P Pull High Resistor	R <sub>KH</sub>		-	300	500	KΩ
Key Tone Output Current	I <sub>KTH</sub>	V <sub>KTH</sub> = 2.0V	0.5	-	-	mA
	I <sub>KTL</sub>	V <sub>KTH</sub> = 0.5V	0.5	-	-	
HFO Drive/Sink Current	I <sub>HFH</sub>	V <sub>HFH</sub> = 2.0V	0.5	-	-	mA
	I <sub>HFL</sub>	V <sub>HFL</sub> = 0.5V	0.5	-	-	
Keypad Input Drive Current	I <sub>KD</sub>	V <sub>I</sub> = 0V	30	-	-	μA
Keypad Input Sink Current	I <sub>KS</sub>	V <sub>I</sub> = 2.5V	200	400	-	μA
Keypad Resistance			-	-	5.0	KΩ

# W91590 SERIES



## AC CHARACTERISTICS

PARAMETER	SYM.	CONDITIONS	MIN.	TYP.	MAX.	UNIT
Keypad Active in Debounce	TKID	-	-	20	-	mS
Key Release Debounce	TKRD	-	-	20	-	mS
Pre-digit Pause <sup>1</sup>	TPDP1	MODE Pin = 1	-	40	-	mS
		MODE Pin = Floating	-	33.3	-	
Pre-digit Pause <sup>2</sup>	TPDP2	MODE Pin = 1	-	20	-	mS
		MODE Pin = Floating	-	16.7	-	
Interdigit Pause (Auto dialing)	TIDP	10 ppS	-	800	-	mS
		20 ppS	-	500	-	
Make/Break Ratio	M/B	MODE Pin = 1	-	40:60	-	%
		MODE Pin = Floating	-	33:67	-	
Tone Output Duration	TTD	Auto Dialing	-	93	-	mS
Intertone Pause	TITP	Auto Dialing	-	93	-	mS
Flash Break Time	TFB	-	-	98	-	mS
			-	305	-	
			-	600	-	
Pause Time	TP	-	-	3.6	-	S
Key Tone Frequency	FKT	-	-	600	-	Hz
Key Tone Duration	TKTD	-	-	35	-	mS
One-key Redialing Pause Time	TPR	-	-	600	-	mS
One-key Redialing Break Time	TRB	-	-	2.2	-	S
First Key-in Pause Time	TFKP	-	-	600	-	mS

Notes:

- Crystal parameters suggested for proper operation are  $R_s < 100 \Omega$ ,  $L_m = 96 \text{ mH}$ ,  $C_m = 0.02 \text{ pF}$ ,  $C_n = 5 \text{ pF}$ ,  $C_l = 18 \text{ pF}$ ,  $F_{osc.} = 3.579545 \text{ MHz} \pm 0.02\%$ .
- Crystal oscillator accuracy directly affects these times.

## TIMING WAVEFORMS

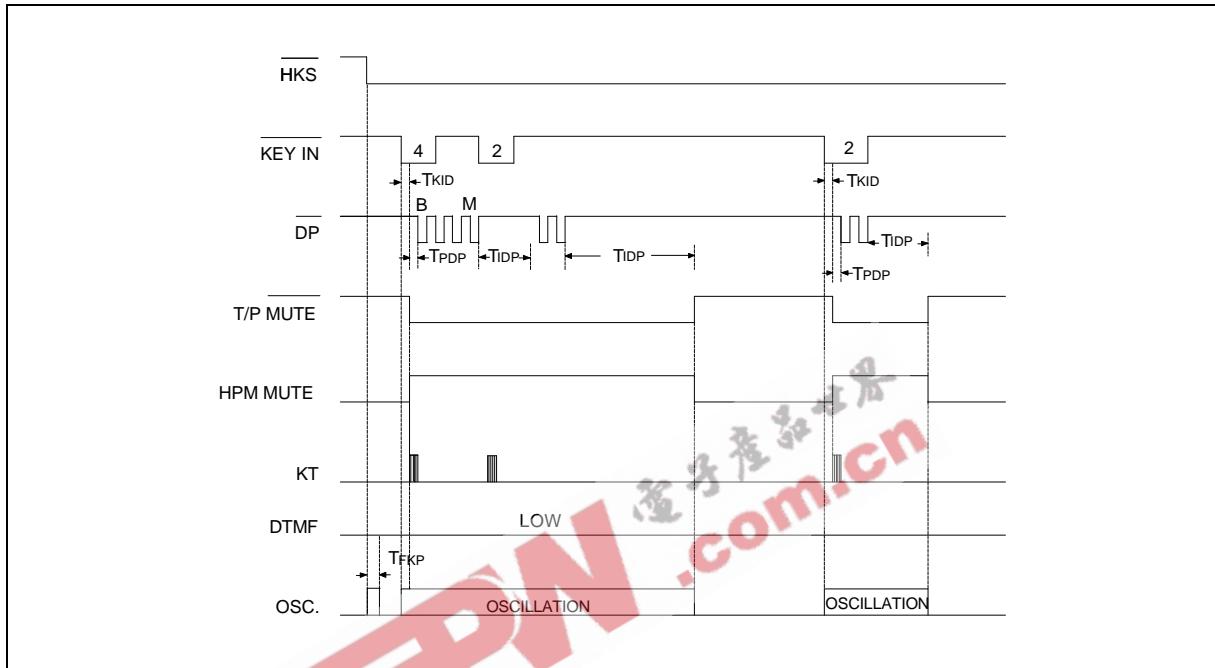

Figure 1. Pulse Mode Diagram (Normal Dialing)

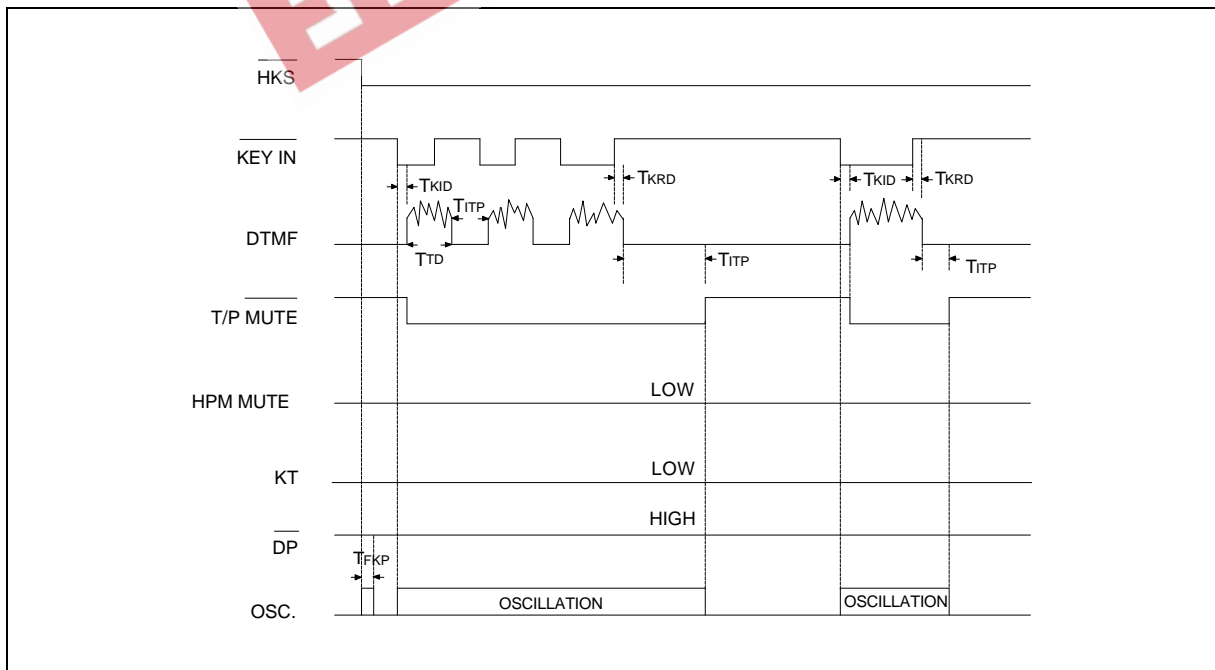

Figure 2. Tone Mode Diagram (Normal Dialing)

# W91590 SERIES



Timing Waveforms, continued

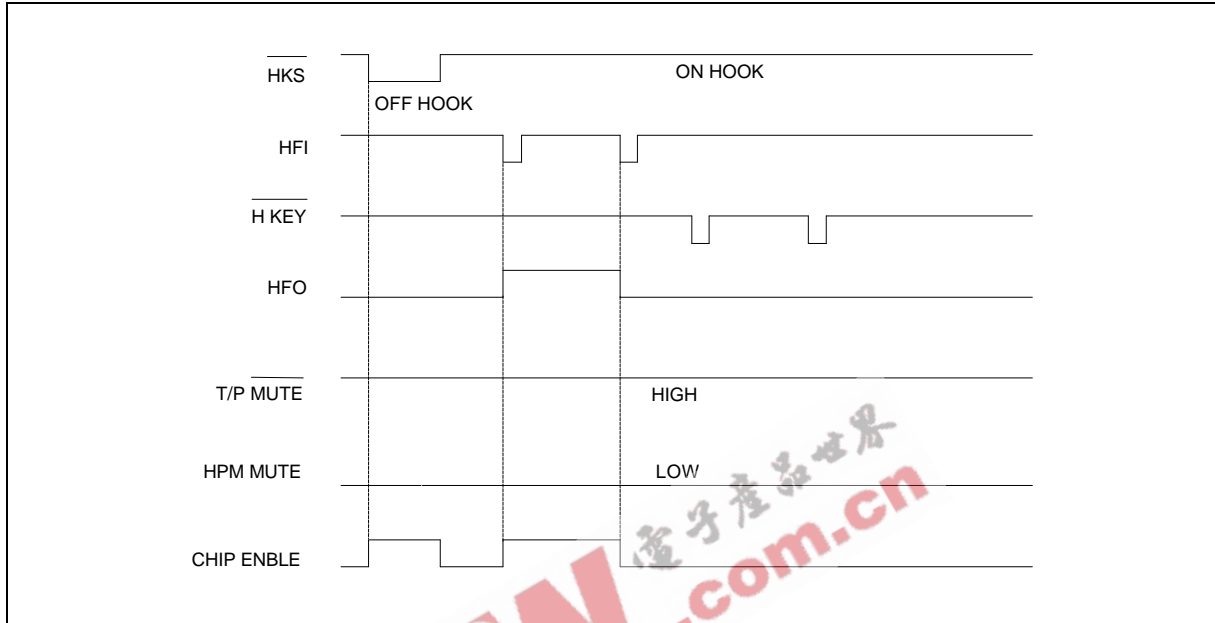

Figure 3(a).

Note: The H KEY cannot be enabled when chip is disabled.

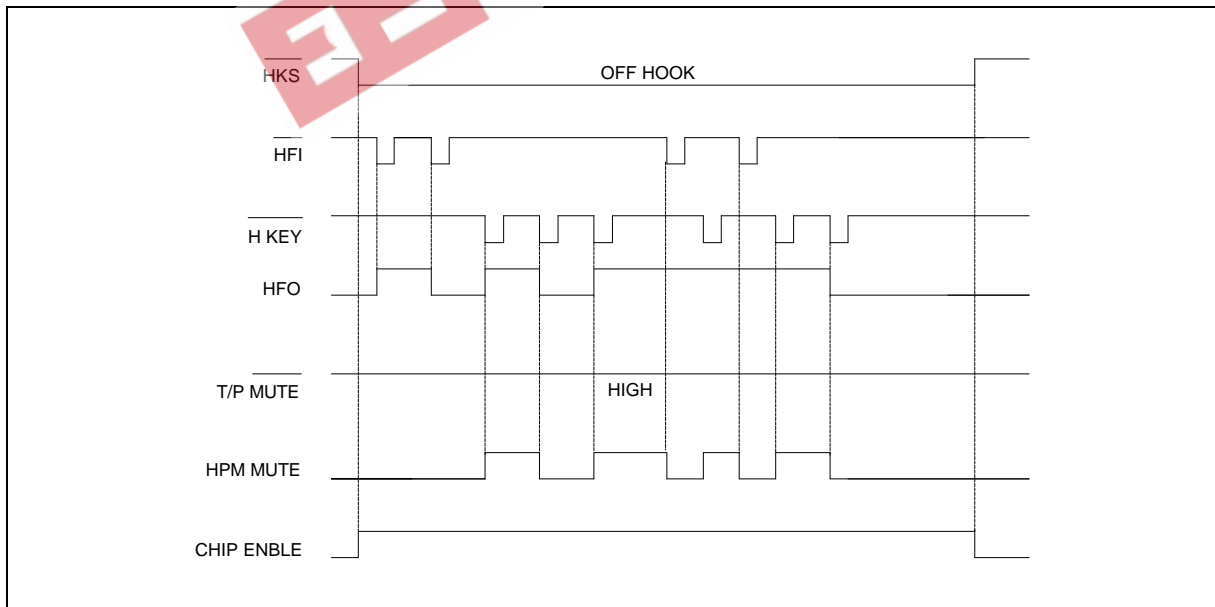

Figure 3(b).

Note: The HFI and HFI inputs will toggle the HFO signal; as soon as either HFI or H KEY is activated the HFO signal will go high and previous inputs will be ignored.



# W91590 SERIES



Timing Waveforms, continued

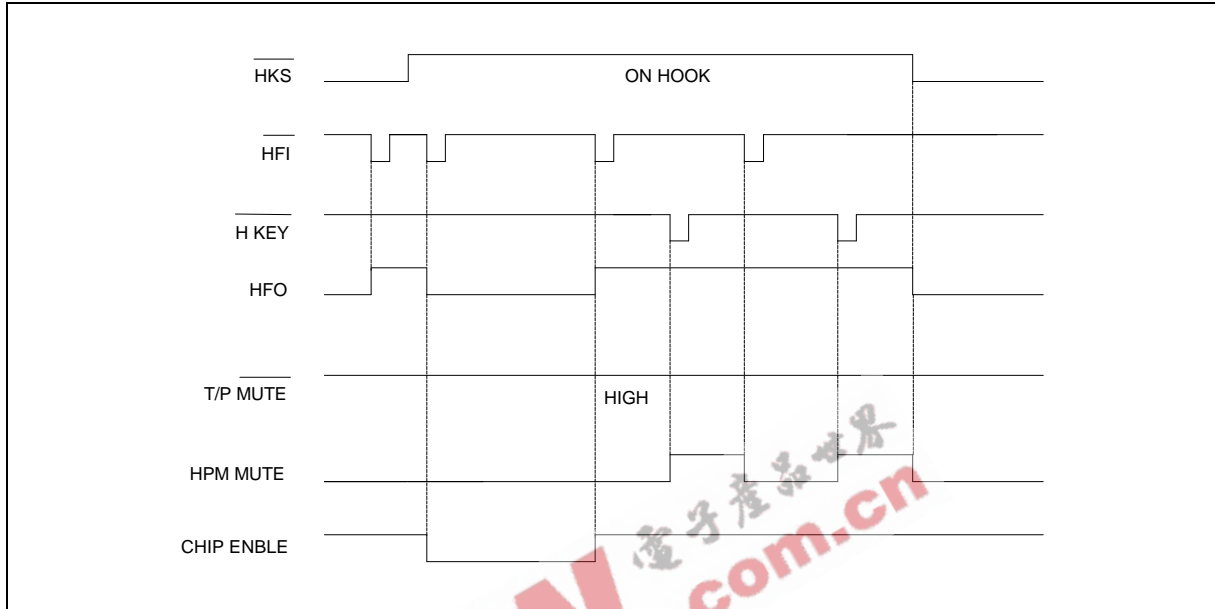

Figure 3(c).

Note: Changing the state of the HKS signal from high to low will initialize the HFO and HPM MUTE signals.

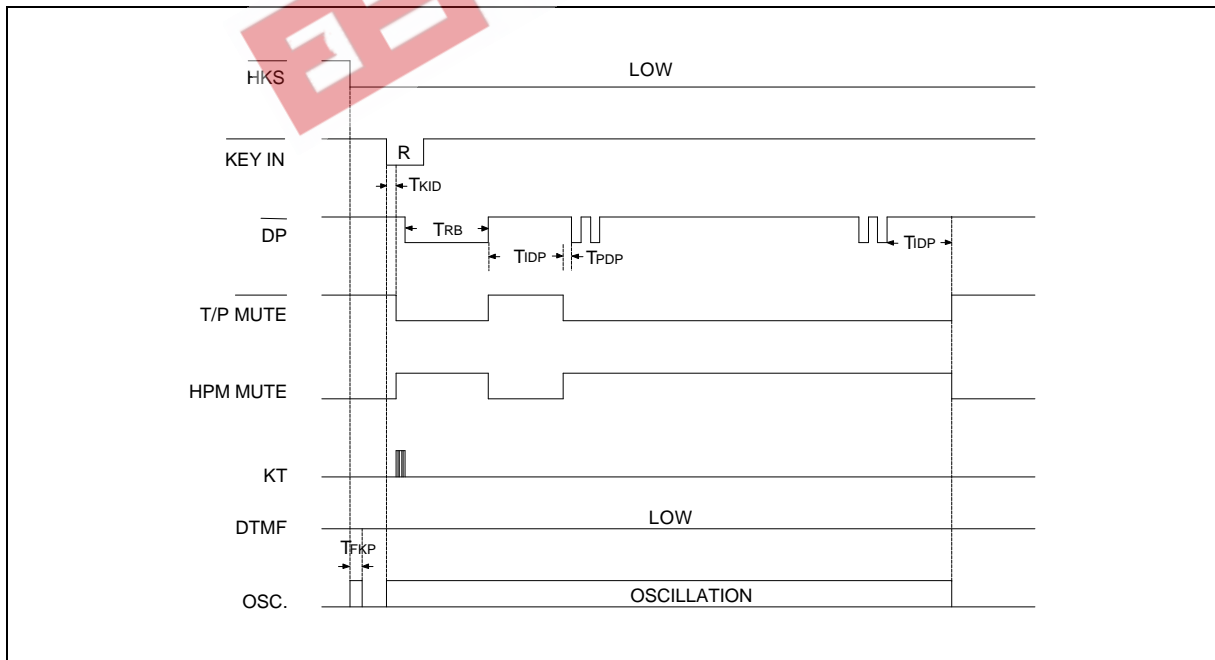

Figure 4. Pulse Mode One-key Redialing Timing Diagram (when not first key)

# W91590 SERIES



Timing Waveforms, continued

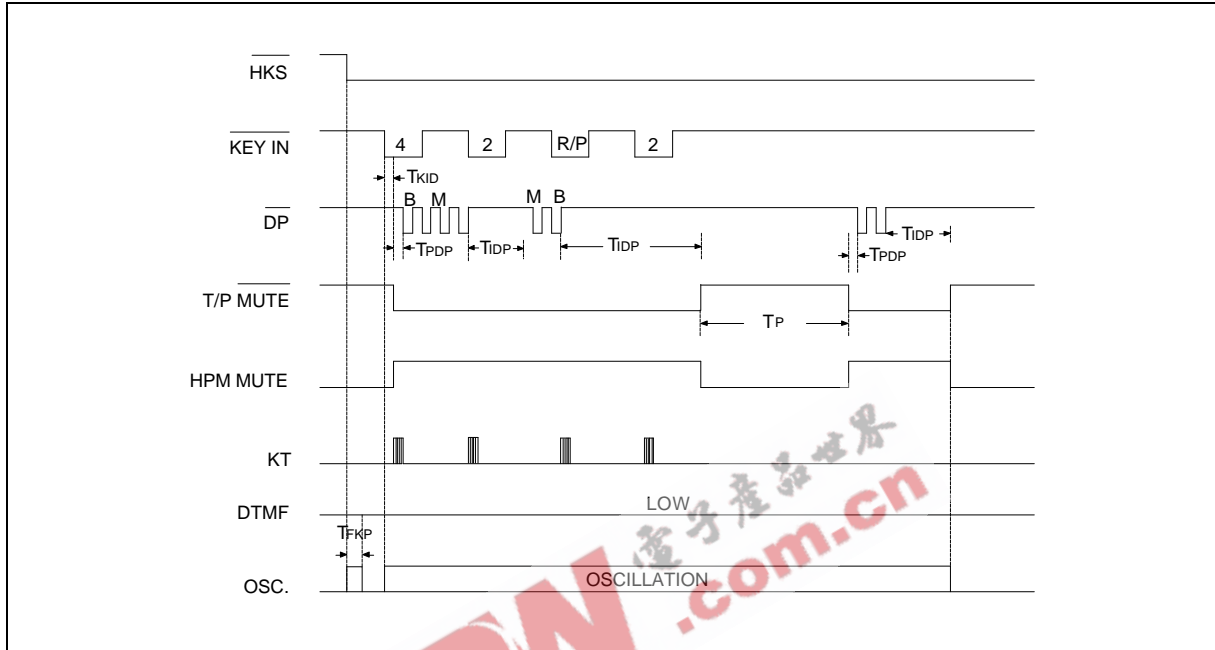

Figure 5. Pause Function Timing Diagram

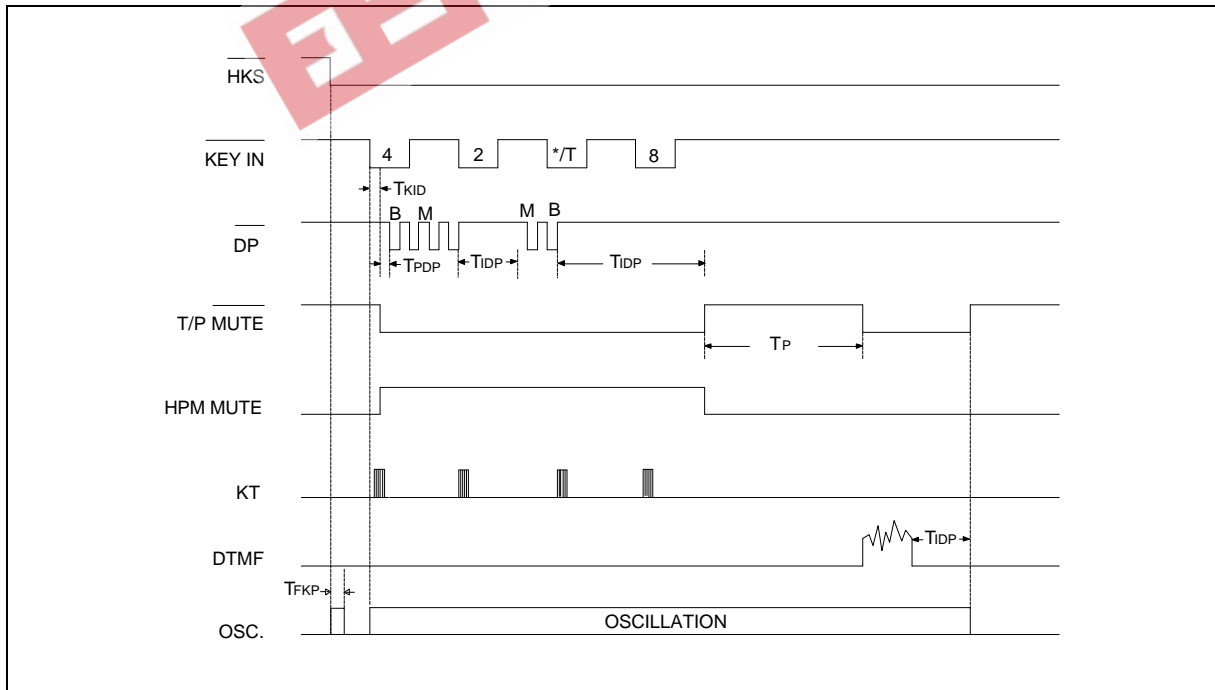

Figure 6. Pulse-to-Tone Function Timing Diagram

# W91590 SERIES



Timing Waveforms, continued

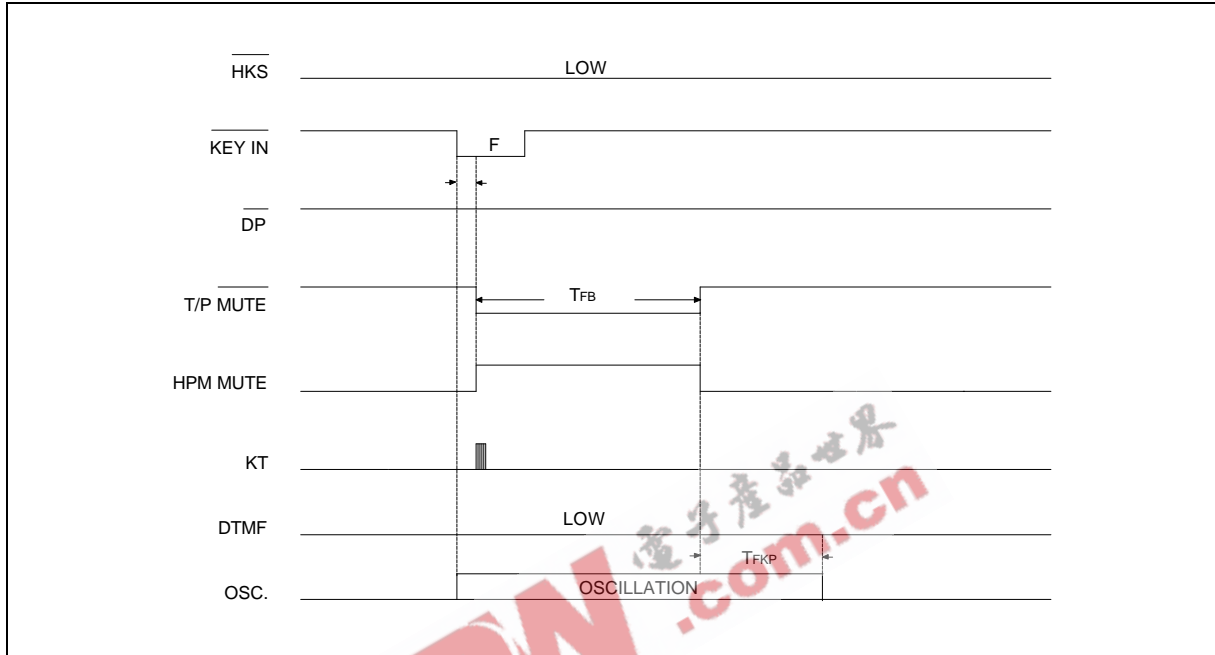

Figure 7. Flash Operation Timing Diagram

# W91590 SERIES



EEPW 电子產品世界  
.com.cn



#### Headquarters

No. 4, Creation Rd. III,  
Science-Based Industrial Park,  
Hsinchu, Taiwan  
TEL: 886-3-5770066  
FAX: 886-3-5792697  
<http://www.winbond.com.tw/>  
Voice & Fax-on-demand: 886-2-7197006

#### Taipei Office

11F, No. 115, Sec. 3, Min-Sheng East Rd.,  
Taipei, Taiwan  
TEL: 886-2-7190505  
FAX: 886-2-7197502

#### Winbond Electronics (H.K.) Ltd.

Rm. 803, World Trade Square, Tower II,  
123 Hoi Bun Rd., Kwun Tong,  
Kowloon, Hong Kong  
TEL: 852-27516023  
FAX: 852-27552064

#### Winbond Electronics North America Corp.

**Winbond Memory Lab.**  
**Winbond Microelectronics Corp.**  
**Winbond Systems Lab.**

2730 Orchard Parkway, San Jose,  
CA 95134, U.S.A.  
TEL: 1-408-9436666  
FAX: 1-408-9436668

Note: All data and specifications are subject to change without notice.