

# W55RFS27R1B Data Sheet



## SUPER-REGENERATION RF RECEIVER

### Table of Content-

1.	GENERAL DESCRIPTION .....	2
1.1	W55RFS27R1B Features .....	2
1.2	W55RFS27R1B Pad Definition .....	3
1.2.1	Pad Description .....	3
1.2.2	Mode selection .....	4
2.	SYSTEM DESCRIPTION .....	5
2.1	W55RFS27R1B System Block Diagram .....	5
2.2	W55RFS27R1B Functional Description .....	6
3.	ELECTRONIC CHARACTERISTICS .....	7
3.1	W55RFS27R1B Absolute Maximum Ratings .....	7
3.2	W55RFS27R1B DC Characteristics .....	8
3.3	W55RFS27R1B Ordering Information .....	9
3.4	W55RFS27R1B Package Information .....	9
3.4.1	W55RFS27R1B Bonding Pad List .....	9
3.4.2	W55RFS27R1B Bonding Pad Diagram .....	10
4.	DESIGN INFORMATION .....	11
4.1	W55RFS27R1B Reference Design .....	11
4.1.1	W55RFS27R1B Application Circuit .....	11
4.2	W55RFS27R1B <i>Smart-Detector</i> <sup>WB</sup> Function .....	13
4.2.1	Introduction .....	13
4.2.2	Using <i>Smart-Detector</i> <sup>WB</sup> in <i>Manual-mode</i> .....	13
4.2.3	Using <i>Smart-Detector</i> <sup>WB</sup> in <i>uC-mode</i> .....	13
4.3	W55RFS27R1B Layout Guide .....	14
5.	REVISION HISTORY .....	15



## 1. GENERAL DESCRIPTION

The Winbond W55RFS27R1B is a fully integrated, S-R (Super-regeneration) RF receiver with full-function baseband command decoder for R/C vehicles, toys, or wireless data communication applications.

The W55RFS27R1B provides two input modes: **uC-mode**, for general-purpose, micro-controller interfaces to the RF transmitter (the decoder is disabled); and **manual-mode**, for a 6-function, baseband command decoder and RF receiver that works conveniently with the W55RFS27T1B to provide a simple remote control capability with low cost and high performance.

The W55RFS27R1B includes the **Smart-Detector<sup>WB</sup>** function, which makes the W55RFS27R1B the most suitable receiver for mass-produced applications. **Smart-Detector<sup>WB</sup>** overcomes the effects of component deviation and various kinds of environmental problems, such as temperature, moisture, or object-caused, antenna characteristic changes, to maintain maximum sensitivity.

The Super-Regenerative RF front-end architecture operates at 27 MHz, 35 MHz, 40 MHz, or 49MHz with a minimum number of external components. In addition, the W55RFS27R1B accommodates a wide range of operating voltages (2.1 V to 5.5 V) and supports 2- or 3-battery R/C applications.

### 1.1 W55RFS27R1B Features

- Operating frequencies: 27 MHz, 35 MHz, 40 MHz, 49 MHz
- **Smart-Detector<sup>WB</sup>** function overcomes component deviation and environmental problems to maintain highest sensitivity
- Wide operating voltage: 2.1 V ~ 5.5 V
- S-R (Super-regeneration) demodulation scheme
- (uC-mode) Receiving data rates up to 1.25Kbps for 50% duty cycle signals
- (manual-mode) R/C-toy baseband control command decoder, supporting 6 functions; Forward, Backward, Left-turn, Right-turn, and 2 user-defined functions F1 and F2
- Minimum current consumption
- Very low power-down current consumption (**uC-mode** only)
- Minimum number of external components
- Dice form available for PCB bonding
- Operating temperature: 0°C ~ 70°C

# W55RFS27R1B



## 1.2 W55RFS27R1B Pad Definition

### 1.2.1 Pad Description

SYMBOL	PAD NO.	I/O	FUNCTIONAL DESCRIPTION
GND	1	Ground	Ground return path
CMFB	2	O	Common-mode feedback capacitor connection
RBIAS	3	I	Resistor to adjust internal circuit bias
RSAW	4	O	Resistor to control internal saw generator
VDDA	5	Power	Regulated voltage output
OSCI <sub>n</sub>	6	I	Oscillator tank input
OSCO <sub>u</sub> t	7	O	Oscillator tank output
GND <sub>A</sub>	8	Ground	Regulator ground return path
Reset	9	I	Reset = 0 resets whole chip, internally pulled high
Mode0	10	I	Mode select LSB, please see 1.2.2 for details
Mode1	11	I	Mode select MSB, please see 1.2.2 for details
TEST	12	I	TEST = 1 for chip testing; must be set to "0" for regular operation.
F2	13	O/I	(manual mode) Decoder F2 output (uC-mode) \$ENB ("0" = power down)*
F1	14	O/I	(manual mode) Decoder F1 output (uC-mode) Not used; set to "0"*
R	15	O/I	(manual mode) Decoder Right-turn output (uC-mode) HOPCLK; set to "0"*
L	16	O/I	(manual mode) Decoder Left-turn output (uC-mode) \$OAGC2; set to "0" *
B	17	O/I	(manual mode) Decoder Backward output (uC-mode) \$OAGC1; set to "1" *
F	18	O/I	(manual mode) Decoder Forward output (uC-mode) \$OAGC0; set to "0" *
RXD	19	O/I	Receiver data output
VSPLY	20	Power	Power input

(\* For uC-mode control, please see section 4.2 W55RFS27R1B *Smart-Detector*<sup>WB</sup> Function)

## 1.2.2 Mode selection

(MODE1,MODE0)	FUNCTION DESCRIPTION	NOTE
(0,0)	Disable <b>Smart-Detector<sup>WB</sup></b> Function	Function evaluation only
(0,1)	<b>uC-mode</b> , <b>Smart-Detector<sup>WB</sup></b> function is externally-controlled	Baseband decoder is disabled
(1,0)	<b>Manual-mode</b> , Enable half of <b>Smart-Detector<sup>WB</sup></b> function OAGC OFF , HOPPING ON	Function evaluation only
(1,1)	<b>Manual-mode</b> , Enable <b>Smart-Detector<sup>WB</sup></b> function OAGC ON, HOPPING ON	Suitable for mass-production

## 2. SYSTEM DESCRIPTION

### 2.1 W55RFS27R1B System Block Diagram

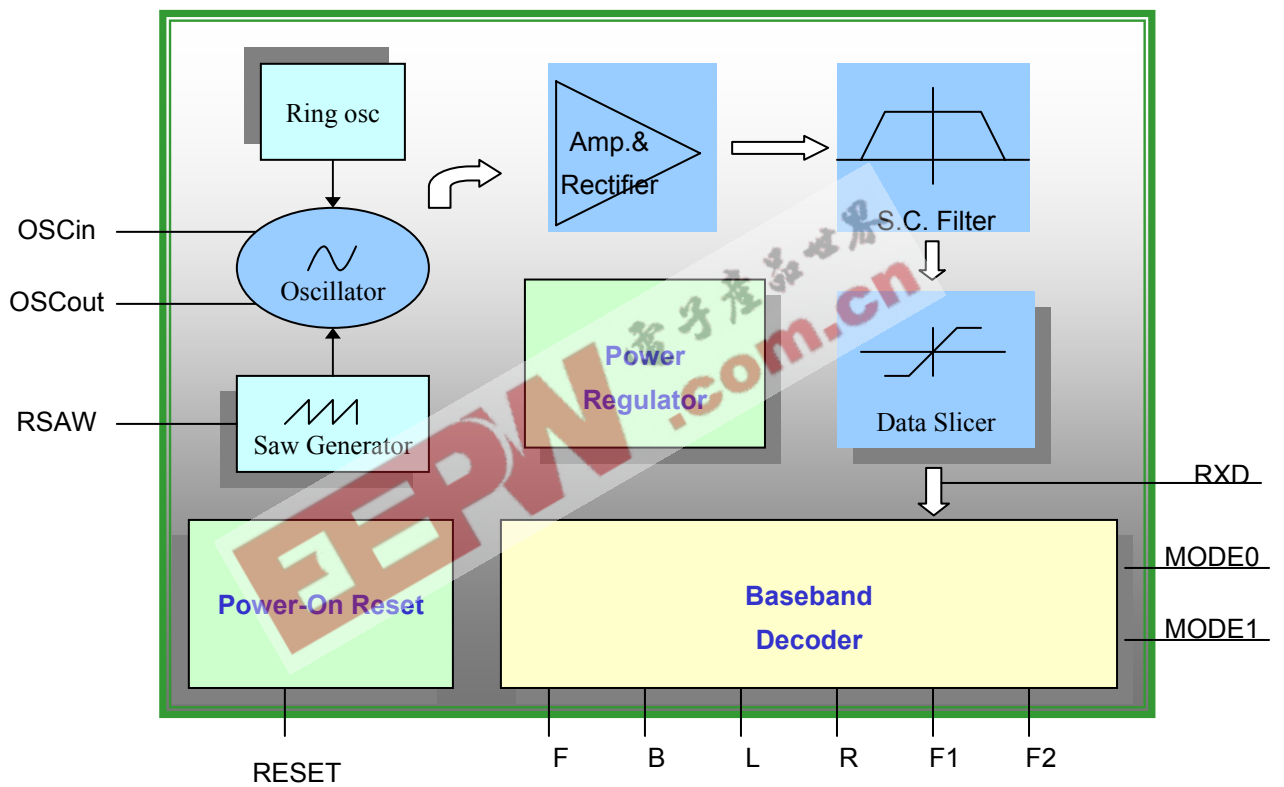



## 2.2 W55RFS27R1B Functional Description

### Power Regulator

The W55RFS27R1B built-in power regulator provides stable operating performance for operating voltages from 2.1 to 5.5 V, a very wide range of voltages suitable for 2- or 3-battery R/C toys or R/C vehicles.

### RF Receiver

The W55RFS27R1B has been implemented using a "Super-Regenerative" receiving architecture. The resulting high noise immunity is suitable for getting higher RF receiving performance in very noisy environments. In addition, the **Smart-Detector<sup>WB</sup>** function overcomes component deviation and various environmental problems to provide the highest receiver sensitivity, making it quite suitable for mass-produced applications.

### Baseband Control Function Decoder

The W55RFS27R1B has a built-in, 6-function baseband control function decoder for R/C toys. The six functions include **Forward**; **Backward**; **Left-turn**; **Right-turn**, and two user-defined functions **F1** and **F2**.



## 3. ELECTRONIC CHARACTERISTICS

### 3.1 W55RFS27R1B Absolute Maximum Ratings

PARAMETER	RATING	UNIT
Supply Voltage to Ground Potential	- 0.3 to 6.5	V
Applied Input/Output Voltage	- 0.3 to 6.5	V
Power Dissipation ( $T_a = 70^{\circ}\text{C}$ )	150	mW
Ambient Operating Temperature	0 to 70	$^{\circ}\text{C}$
Storage Temperature	-40 to 85	$^{\circ}\text{C}$

**Note:** Exposure to conditions beyond those listed under Absolute Maximum Ratings may adversely affect the life and reliability of the device.

EEPW 电子产品世界 .com.cn

# W55RFS27R1B



## 3.2 W55RFS27R1B DC Characteristics

(VDD-VSS = 3 V, Ta = 25°C; unless otherwise specified)

PARAMETER	SYM.	CONDITIONS	MIN.	TYP.	MAX.	UNIT
Power Supply						
Operating Voltage	V <sub>DD</sub>		2.1	-	5.5	V
Operating Current	I <sub>OP</sub>		-	-	2.8	mA
Stand-by Current	I <sub>SBY</sub>	\$ENB= 0	-	-	2	μA
Regulated Voltage	V <sub>DDA</sub>		1.65	1.8	2.1	V
Digital Input/Output Pin						
Input High Voltage	V <sub>IH</sub>		0.8*V <sub>D</sub>	-	V <sub>DD</sub>	V
Input Low Voltage	V <sub>IL</sub>		V <sub>SS</sub>	-	0.1*V <sub>DD</sub>	V
F,B,L,R,F1,F2 Output High Source Current	I <sub>OH</sub>	V <sub>OH</sub> =0.7 * V <sub>DD</sub>	6	-	-	mA
F,B,L,R,F1,F2 Output Low Sink Current	I <sub>OL</sub>	V <sub>OL</sub> =0.3 * V <sub>DD</sub>	6	-	-	mA
RXD Output High Source Current	I <sub>OH</sub>	V <sub>OH</sub> =0.7 * V <sub>DD</sub>	2	-	-	mA
RXD Output Low Sink Current	I <sub>OL</sub>	V <sub>OL</sub> =0.3 * V <sub>DD</sub>	2	-	-	mA
<b>Crystal Oscillator</b>						
Operation Frequency	F <sub>C</sub>		27	-	49.8	MHz
On-chip Ring Oscillator frequency	T <sub>OSC</sub>		170	200	250	KHz
Baseband Decoder Section						
Modulation Duty Cycle	M <sub>DYT</sub>		40	50	60	%
Received Data Rate	R <sub>DTT</sub>	50% Duty-cycle Manchester Code	-	1.25	-	Kbps



# W55RFS27R1B



## 3.3 W55RFS27R1B Ordering Information

The W55RFS27R1B is available in two types: Dice form and Wafer form.

PART NUMBER	PACKAGE	REMARKS
W55RFS27R1B(H)	Dice form	
W55RFS27R1B(W)	Wafer form	

## 3.4 W55RFS27R1B Package Information

### 3.4.1 W55RFS27R1B Bonding Pad List

Window : (xl = -929.000, yl = -625.000),  
(xh = 929.000, yh = 625.000)

Windows size : Width = 1858.000, length = 1250.000

PAD NO	PAD NAME	PIN NAME	X	Y
1	* GND	* 1	-13.000	540.000
2	CMFB	2	-365.950	540.000
3	RBIAS	3	-472.950	540.000
4	RSAW	4	-579.950	540.000
5	VDDA	5	-689.350	540.000
6	VDDA	5	-801.150	540.000
7	OSCin	6	-795.075	-540.000
8	OSCoout	7	-667.875	-540.000
9	GND	8	-555.150	-540.000
10	reset	9	-128.675	-540.000
11	MODE0	10	-21.675	-540.000
12	MODE1	11	85.325	-540.000
13	TEST	12	192.325	-540.000
14	F2	13	302.925	-540.000
15	F1	14	790.325	540.000
16	R	15	675.875	540.000
17	L	16	561.425	540.000
18	B	17	446.975	540.000
19	F	18	332.525	540.000
20	RXD	19	218.075	540.000
21	VSPLY	20	98.400	540.000

(\*: Bonding Sequence start from GND(Pin1))

# W55RFS27R1B



## 3.4.2 W55RFS27R1B Bonding Pad Diagram

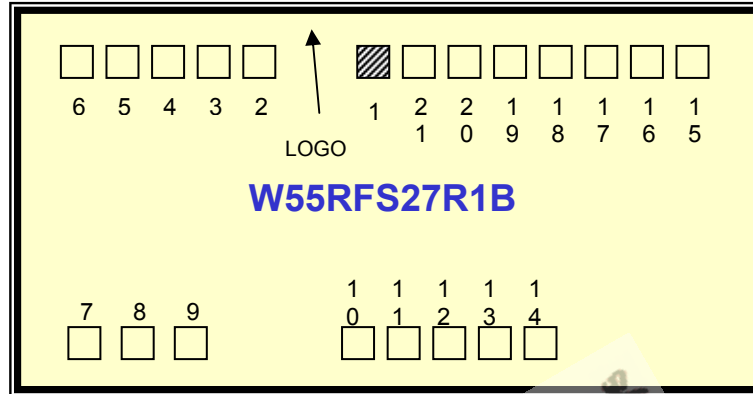

# W55RFS27R1B



## 4. DESIGN INFORMATION

### 4.1 W55RFS27R1B Reference Design

#### 4.1.1 W55RFS27R1B Application Circuit

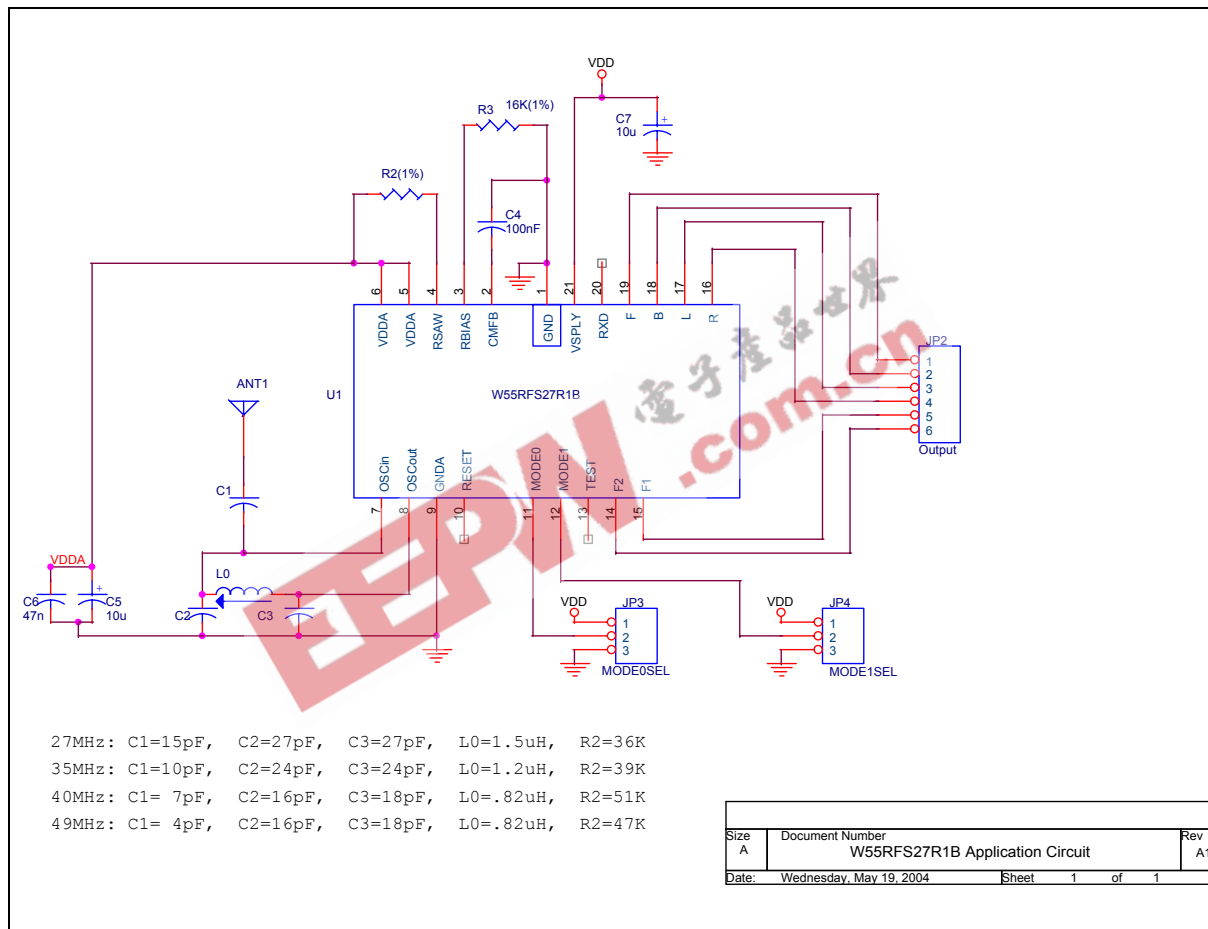

(\* **Note:** The component values are suitable for a 15-cm antenna. Different antenna might change RSAW (R2).)

# W55RFS27R1B



## W55RFS27R1B Application Schematic BOM:

Item	Qty	Reference	Part
1	1	ANT1	ANTENNA
2	1	C1	4pF
3	1	C2	16P
4	1	C3	18P
5	1	C4	100nF
6	2	C7,C5	10u
7	1	C6	47n
8	1	JP2	Output
9	1	JP3	MODE0SEL
10	1	JP4	MODE1SEL
11	1	L0	0.82u
12	1	R2	47K(1%)
13	1	R3	16K(1%)
14	1	U1	W55RFS27R1B



## 4.2 W55RFS27R1B *Smart-Detector*<sup>WB</sup> Function

### 4.2.1 Introduction

The *Smart-Detector*<sup>WB</sup> function is designed to overcome the effects of component deviation and environmental changes. It enables the on-chip OAGC (Oscillator Auto-Gain-Control) and hopping clock functions, dynamically searching for the best operating conditions and

maintaining the highest sensitivity in different environments.

In *manual-mode*, the control mechanism is built in while, in *uC-mode*, the OAGC and hopping functions are fixed or controlled by the external MCU.

### 4.2.2 Using *Smart-Detector*<sup>WB</sup> in *Manual-mode*

a). Set [MODE1:MODE0] to [00] to disable *Smart-Detector*<sup>WB</sup>. Then, select RSAW to provide the highest sensitivity. Note the default values for OAGC and HOPCLK are OAGC[2:0] = {0,1,0} and HOPCLK = 0.

b). Set [MODE1:MODE0] to [11] to enable *Smart-Detector*<sup>WB</sup>. Then, OAGC[2:0] change according to the following sequence, and HOPCLK toggles once ("0" => "1" or "1" => "0") every T seconds.

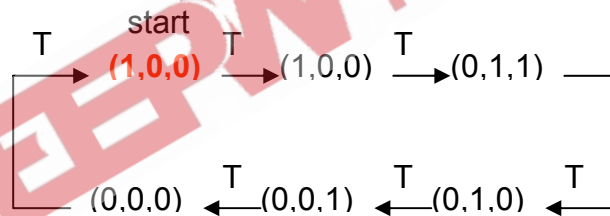

( T ≈ 20ms)

c). When a data packet is received, the W55RFS27R1B holds the current OAGC and HOPCLK settings for around 50ms. When there is no more data input, OAGC and HOPCLK resume sequencing and toggling.

### 4.2.3 Using *Smart-Detector*<sup>WB</sup> in *uC-mode*

In *uC-mode*, OAGC[2:0] and HOPCLK are externally controlled. They can be fixed at specific values or changed to follow the sequence described in manual-mode. Winbond recommends using fixed settings in *uC-mode* because it can be difficult for the MCU to control these pins.

When OAGC and HOPCLK are fixed, the corresponding pins should be set to OAGC[2:0] = (0,1,0) and HOPCLK = 0. Component deviation should be controlled tightly for consistent results in mass-produced applications.

When following the sequence above, the switching time  $T$  should be based on the data repeat time of the transmitter. Usually, the switching time is twice the repeat time. For example, if a transmitter sends data every 10 ms, then the switching time  $T$  should be 20 ms.

### 4.3 W55RFS27R1B Layout Guide

- a). Make the antenna signal input path (ANT->C1->L0,C2,C3) as short as possible, and keep it away from any sources of noise.
- b). Place the oscillation tank components (L0,C2,C3) as close to each other as possible and as close to the OSCin and OSCout pins as possible.
- c). Make the oscillator ground return path (GNDA) as short and as wide as possible to GNDA. Keep this path isolated from noise sources too.

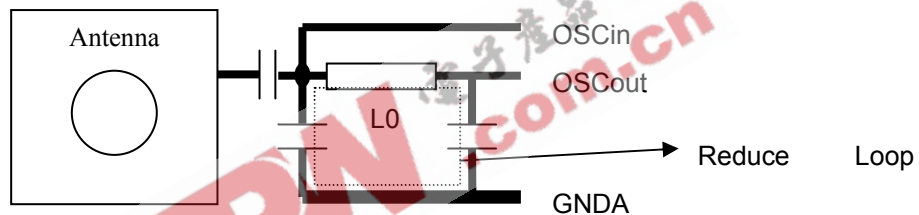

**Pic.1 Graphic representation for a),b),c)**

- d). Separate the oscillation tank ground from the other ground paths, and connect it directly to GNDA.

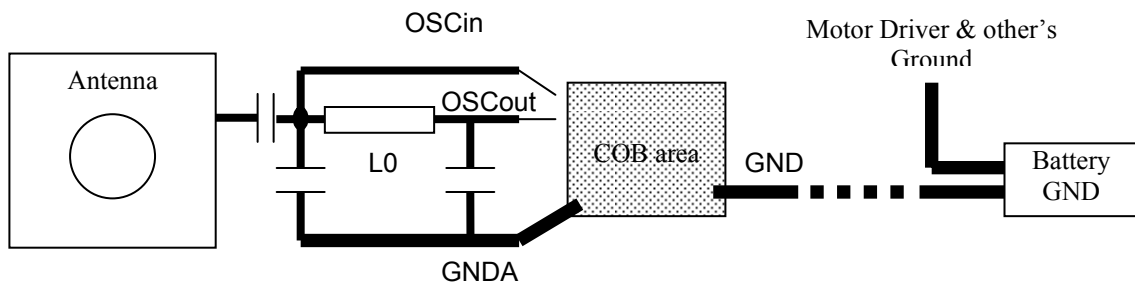

**Pic.2 Graphic representation for d)**



## 5. REVISION HISTORY

VERSION	DATE	PAGE	DESCRIPTION
A1	2004/5/27	-	Preliminary version
A2	2004/7/15	-	Released version A2
A3	2005/5/30	-	Revised by Brand and add important notice

### Important Notice

Winbond products are not designed, intended, authorized or warranted for use as components in systems or equipment intended for surgical implantation, atomic energy control instruments, airplane or spaceship instruments, transportation instruments, traffic signal instruments, combustion control instruments, or for other applications intended to support or sustain life. Further more, Winbond products are not intended for applications wherein failure of Winbond products could result or lead to a situation wherein personal injury, death or severe property or environmental damage could occur.

Winbond customers using or selling these products for use in such applications do so at their own risk and agree to fully indemnify Winbond for any damages resulting from such improper use or sales.



**Headquarters**  
No. 4, Creation Rd. III,  
Science-Based Industrial Park,  
Hsinchu, Taiwan  
TEL: 886-3-5770066  
FAX: 886-3-5665577  
<http://www.winbond.com.tw/>

**Taipei Office**  
9F, No.480, Rueiguang Rd.,  
Neihu Chiu, Taipei, 114,  
Taiwan, R.O.C.  
TEL: 886-2-8177-7168  
FAX: 886-2-8751-3579

**Winbond Electronics Corporation America**  
2727 North First Street, San Jose,  
CA 95134, U.S.A.  
TEL: 1-408-9436666  
FAX: 1-408-5441798

**Winbond Electronics Corporation Japan**  
7F Daini-ueno BLDG, 3-7-18  
Shinyokohama Kohoku-ku,  
Yokohama, 222-0033  
TEL: 81-45-4781881  
FAX: 81-45-4781800

**Winbond Electronics (Shanghai) Ltd.**  
27F, 2299 Yan An W. Rd. Shanghai,  
200336 China  
TEL: 86-21-62365999  
FAX: 86-21-62365998

**Winbond Electronics (H.K.) Ltd.**  
Unit 9-15, 22F, Millennium City,  
No. 378 Kwun Tong Rd.,  
Kowloon, Hong Kong  
TEL: 852-27513100  
FAX: 852-27552064

*Please note that all data and specifications are subject to change without notice.  
All the trade marks of products and companies mentioned in this data sheet belong to their respective owners.*