

W26010A



64K × 16 HIGH-SPEED CMOS STATIC RAM

GENERAL DESCRIPTION

The W26010A is a high-speed, low-power CMOS static RAM organized as 65,536 × 16 bits that operates on a single 5-volt power supply. This device is manufactured using Winbond's high performance CMOS technology.

The W26010A has an active low chip select, separate upper and lower byte selects, and a fast output enable. No clock or refreshing is required. Separate byte select controls (#LB and #UB) allow individual bytes to be written and read. #LB controls I/O1-I/O8, the lower byte. #UB controls I/O9-I/O16, the upper byte. This device is well suited for use in high-density, high-speed system applications.

FEATURES

- High speed access time: 15/20/25 nS (max.)
- Low power consumption:
 - Active: 1.3W (max.)
- Single +5V power supply
- Fully static operation
 - No clock or refreshing
- All inputs and outputs directly TTL compatible
- Three-state outputs
- Data byte control
 - #LB (I/O1-I/O8), #UB (I/O9-I/O16)
- Available packages: 44-pin 400 mil SOJ and Type II TSOP

PIN CONFIGURATION

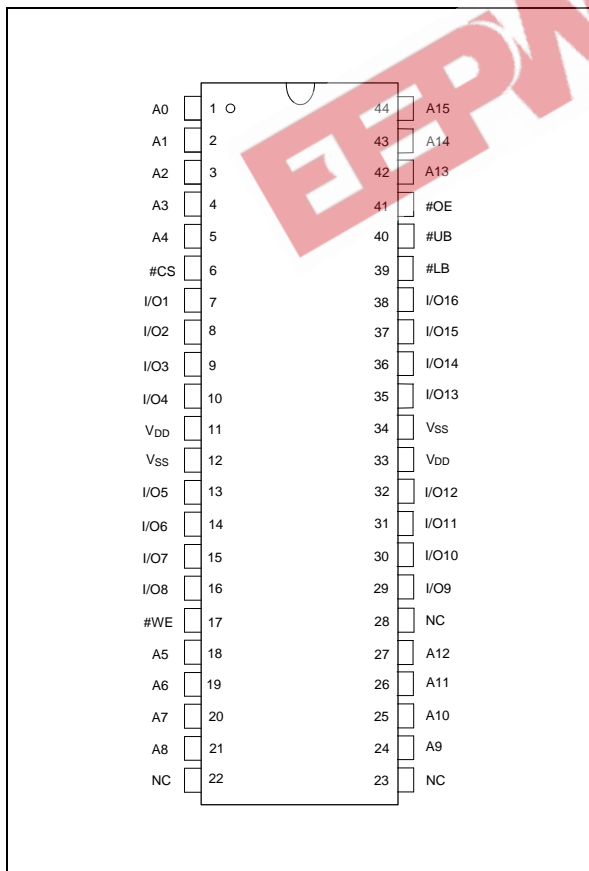

BLOCK DIAGRAM

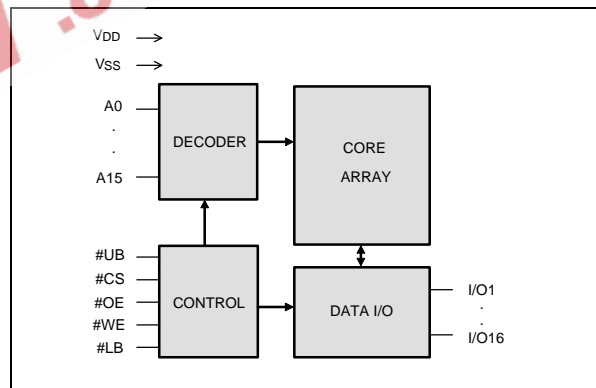

PIN DESCRIPTION

SYMBOL	DESCRIPTION
A0-A15	Address Inputs
I/O1-I/O16	Data Inputs/Outputs
#CS	Chip Select Inputs
#WE	Write Enable Input
#OE	Output Enable Input
#LB	Lower Byte Select I/O1-I/O8
#UB	Upper Byte Select I/O9-I/O16
VDD	Power Supply
VSS	Ground
NC	No Connection



TRUTH TABLE

#CS	#OE	#WE	#LB	#UB	MODE	I/O1- I/O8	I/O9- I/O16	V _{DD} CURRENT
H	X	X	X	X	Not Selected	High Z	High Z	ISB, ISB1
L	H	H	X	X	Output Disable	High Z	High Z	I _{DD}
L	L	H	L	L	2 Bytes Read	DOUT	DOUT	I _{DD}
L	L	H	L	H	Lower Byte Read	DOUT	High Z	I _{DD}
L	L	H	H	L	Upper Byte Read	High Z	DOUT	I _{DD}
L	X	L	L	L	2 Bytes Write	DIN	DIN	I _{DD}
L	X	L	L	H	Lower Byte Write	DIN	High Z	I _{DD}
L	X	L	H	L	Upper Byte Write	High Z	DIN	I _{DD}
L	X	X	H	H	Output Disable	High Z	High Z	I _{DD}

DC CHARACTERISTICS

Absolute Maximum Ratings

PARAMETER	RATING	UNIT
Supply Voltage to V _{SS} Potential	-0.5 to +7.0	V
Input/Output to V _{SS} Potential	-0.5 to V _{DD} +0.5	V
Allowable Power Dissipation	1.5	W
Storage Temperature	-65 to +150	°C
Operating Temperature	0 to +70	°C
	I	

Note: Exposure to conditions beyond those listed under Absolute Maximum Ratings may adversely affect the life and reliability of the device.

Operating Characteristics

(V_{DD} = 5V ±10%, V_{SS} = 0V, T_A = 0 to 70° C, I for -40 to 85° C)

PARAMETER	SYM.	TEST CONDITIONS	MIN.	TYP.	MAX.	UNIT
Input Low Voltage	V _{IL}	-	-0.5	-	+0.8	V
Input High Voltage	V _{IH}	-	+2.2	-	V _{DD} +0.5	V
Input Leakage Current	I _{LI}	V _{IN} = V _{SS} to V _{DD}	-10	-	+10	μA
Output Leakage Current	I _{LO}	V _{I/O} = V _{SS} to V _{DD} Output Pins in High Z See Truth Table	-10	-	+10	μA
Output Low Voltage	V _{OL}	I _{OL} = +8.0 mA	-	-	0.4	V
Output High Voltage	V _{OH}	I _{OH} = -4.0 mA	2.4	-	-	V



Operating Characteristics, continued

PARAMETER	SYM.	TEST CONDITIONS	MIN.	TYP.	MAX.	UNIT	
Operating Power Supply Current	IDD	#CS = VIL (max.),	15	-	-	260	mA
		I/O = open, Cycle = min.	20	-	-	220	
		Duty = 100%	25	-	-	200	
Standby Power Supply Current	ISB	#CS = VIH (min.), I/O = open All other pins = VDD -0.2V/GND	-	-	50	mA	
	ISB1	#CS = VDD -0.2V, I/O = open All other pins = VDD -0.2V/GND	-	-	10	mA	

Note: Typical characteristics are evaluated at VDD = 5V, TA = 25° C.

CAPACITANCE

(VDD = 5V, TA = 25° C, f = 1 MHz)

PARAMETER	SYM.	CONDITIONS	MAX.	UNIT
Input Capacitance	CIN	VIN = 0V	6	pF
Input/Output Capacitance	CI/O	VOUT = 0V	8	pF

Note: These parameters are sampled but not 100% tested.

AC CHARACTERISTICS

AC Test Conditions

PARAMETER	CONDITIONS
Input Pulse Levels	0V to 3V
Input Rise and Fall Times	3 nS
Input and Output Timing Reference Level	1.5V
Output Load	CL = 30 pF, IOH/IOL = -4 mA/8 mA

AC Test Loads and Waveform

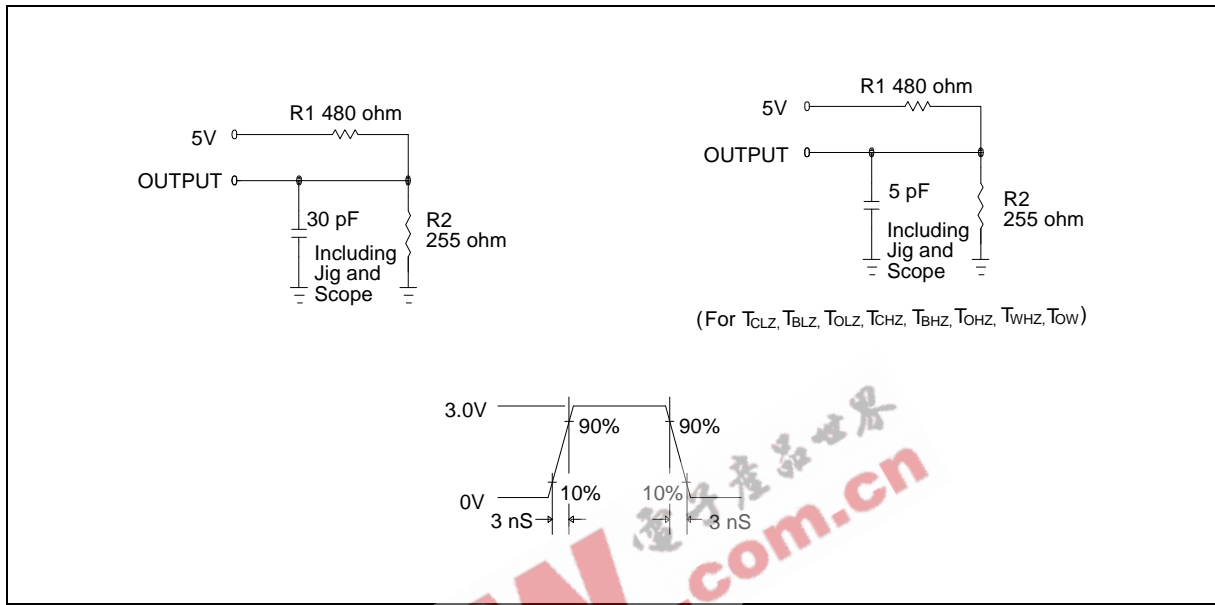

($V_{DD} = 5V \pm 10\%$, $V_{SS} = 0V$, $T_A = 0$ to $70^\circ C$, I for -40 to $85^\circ C$)

Read Cycle

PARAMETER	SYM.	W26010A-15		W26010A-20		W26010A-25		UNIT
		MIN.	MAX.	MIN.	MAX.	MIN.	MAX.	
Read Cycle Time	TRC	15	-	20	-	25	-	nS
Address Access Time	TAA	-	15	-	20	-	25	nS
Chip Select Access Time	TACS	-	15	-	20	-	25	nS
Output Enable to Output Valid	TAOE	-	7	-	10	-	12	nS
#UB, #LB Access Time	TBA	-	7	-	10	-	12	nS
Output Hold from Address Change	TOH	3	-	3	-	3	-	nS
Chip Select to Output in Low Z	TCLZ*	3	-	3	-	3	-	nS
Chip Deselect to Output in High Z	TCHZ*	-	7	-	10	-	12	nS
Output Enable to Output in Low Z	TOLZ*	0	-	0	-	0	-	nS
Output Disable to Output in High Z	TOHZ*	-	7	-	10	-	12	nS
#UB, #LB Select to Output in Low Z	TBLZ*	0	-	0	-	0	-	nS
#UB, #LB Deselect to Output in High Z	TBHZ*	-	7	-	10	-	12	nS

* These parameters are sampled but not 100% tested.

W26010A



AC Characteristics, continued

Write Cycle

PARAMETER	SYM.	W26010A-15		W26010A-20		W26010A-25		UNIT
		MIN.	MAX.	MIN.	MAX.	MIN.	MAX.	
Write Cycle Time	TWC	15	–	20	–	25	–	nS
Chip Select to End of Write	TCW	13	–	17	–	18	–	nS
Address Valid to End of Write	TAW	13	–	17	–	18	–	nS
Address Setup Time	TAS	0	–	0	–	0	–	nS
#UB, #LB Select to End of Write	TBW	13	–	17	–	18	–	nS
Write Pulse Width	TWP	10	–	12	–	15	–	nS
Write Recovery Time	#CS, #WE	TWR	0	–	0	–	0	nS
Data Valid to End of Write	TDW	9	–	10	–	12	–	nS
Data Hold from End of Write	TDH	0	–	0	–	0	–	nS
Write to Output in High Z	TWHZ*	–	8	–	10	–	12	nS
End of Write to Output Active	TOW*	0	–	0	–	0	–	nS

* These parameters are sampled but not 100% tested.

TIMING WAVEFORMS

Read Cycle 1

(Address Controlled, #CS = #OE = #UB = #LB = VIL, #WE = VIH)

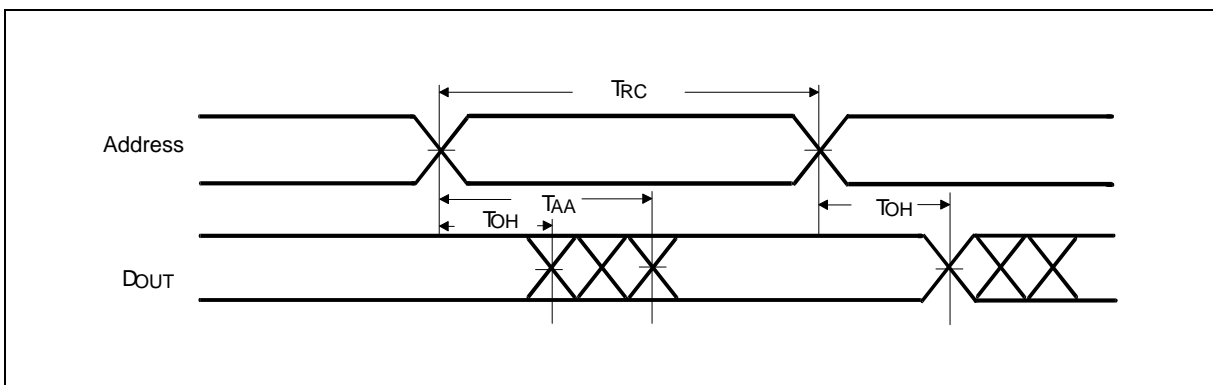



Timing Waveforms, continued

Read Cycle 2

(Chip Select Controlled, #OE = VIL, #WE = VIH)

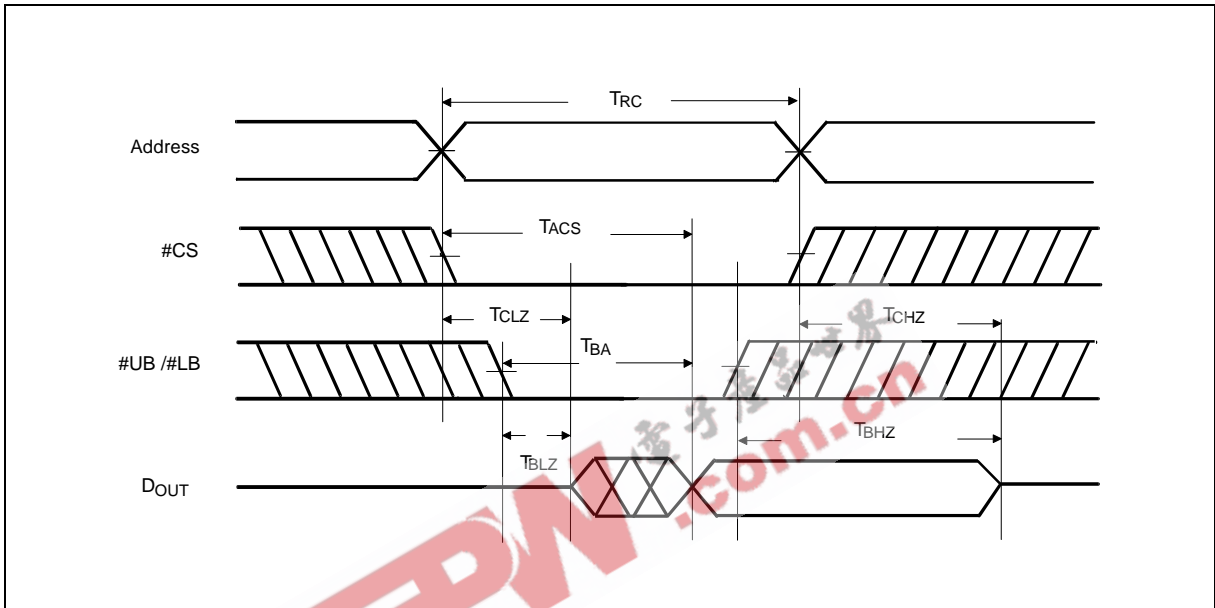

Read Cycle 3

(Output Enable Controlled, #CS = #UB = #LB = VIL, #WE = VIH)

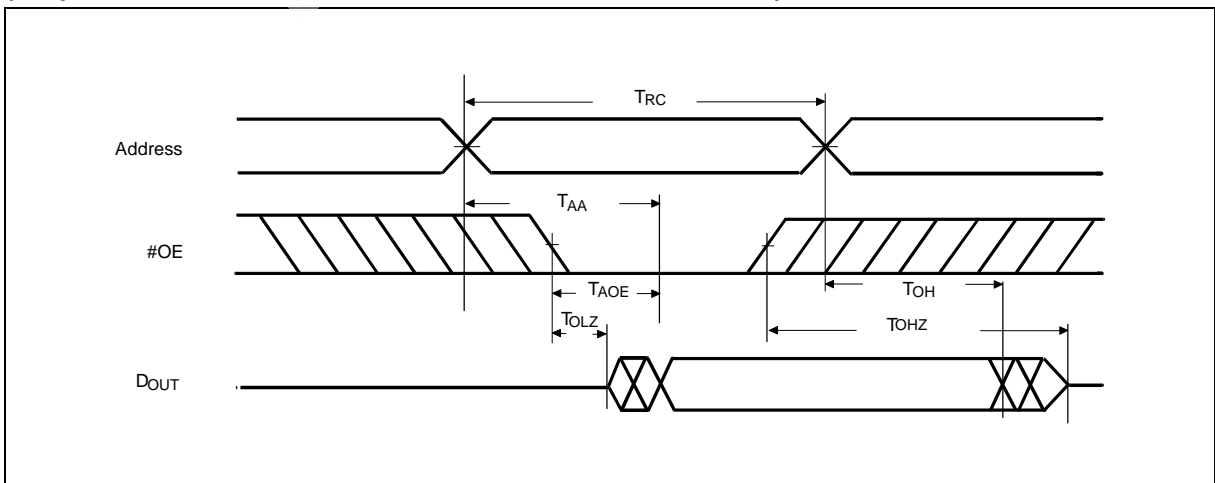



Timing Waveforms, continued

Write Cycle 1

(#OE Clock)

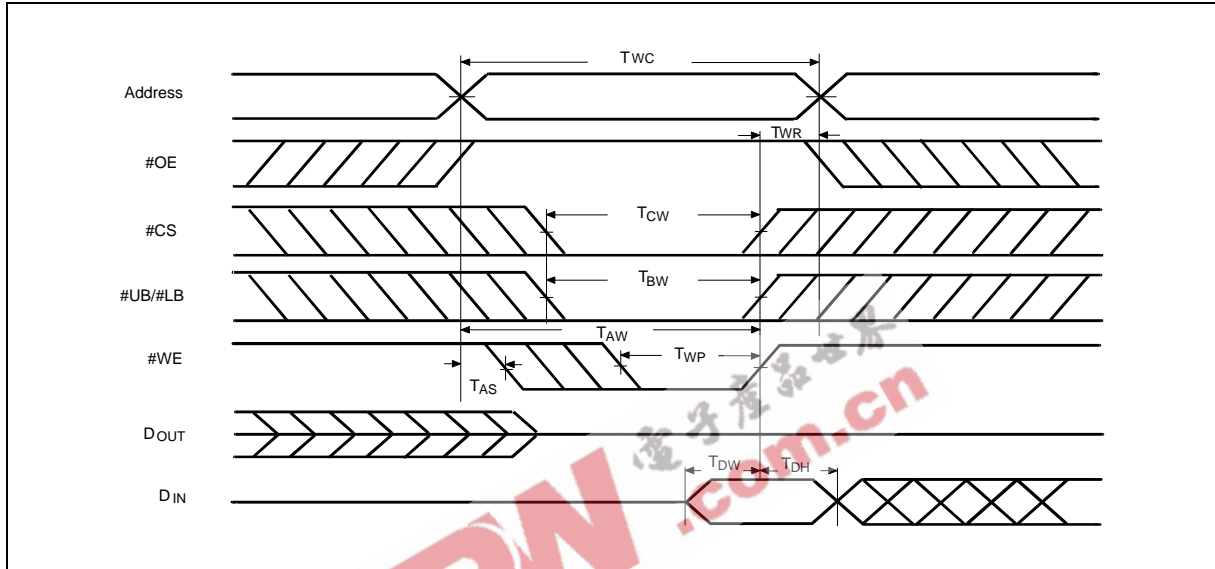

Write Cycle 2

(#OE = VIL Fixed)

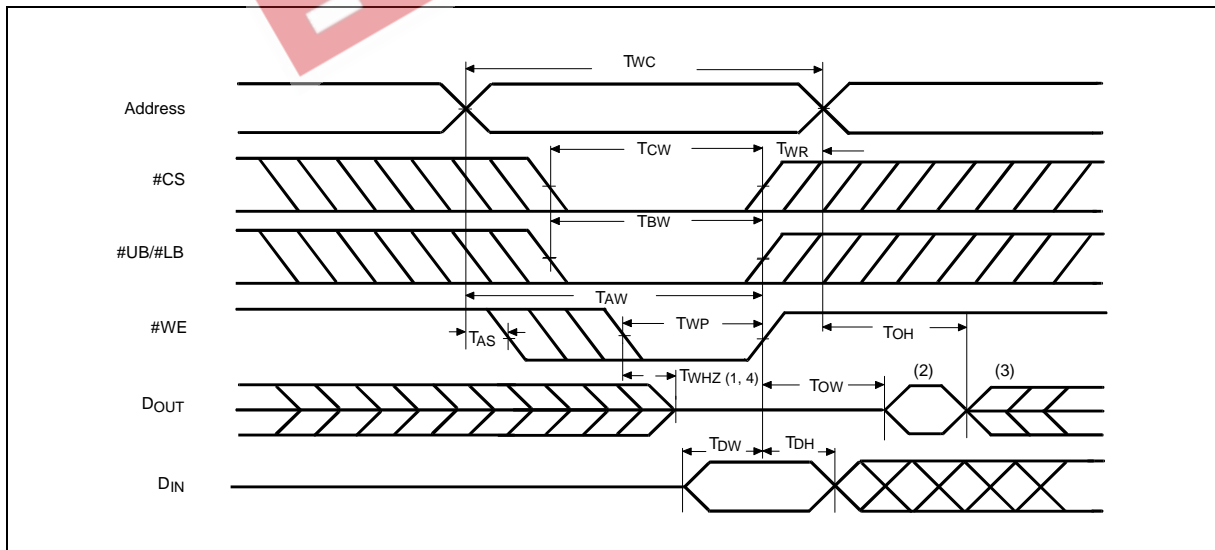

Notes:

1. During this period, I/O pins are in the output state, so input signals of opposite phase to the outputs should not be applied.
2. The data output from DOUT are the same as the data written to DIN during the write cycle.
3. DOUT provides the read data for the next address.
4. Transition is measured ± 500 mV from steady state with $C_L = 5$ pF. This parameter is guaranteed but not 100% tested.

W26010A



ORDERING INFORMATION

PART NO.	ACCESS TIME (nS)	OPERATING CURRENT MAX. (mA)	STANDBY CURRENT MAX. (mA)	OPERATING TEMP. (°C)	PACKAGE
W26010AJ-15	15	260	10	0 to 70	44-pin 400 mil SOJ
W26010AJ-15I	15	260	10	-40 to 85	44-pin 400 mil SOJ
W26010AJ-20	20	220	10	0 to 70	44-pin 400 mil SOJ
W26010AJ-25	25	200	10	0 to 70	44-pin 400 mil SOJ
W26010AT-15	15	260	10	0 to 70	44-pin type two TSOP
W26010AT-15I	15	260	10	-40 to 85	44-pin type two TSOP
W26010AT-20	20	220	10	0 to 70	44-pin type two TSOP
W26010AT-25	25	200	10	0 to 70	44-pin type two TSOP

Notes:

1. Winbond reserves the right to make changes to its products without prior notice.
2. Purchasers are responsible for performing appropriate quality assurance testing on products intended for use in applications where personal injury might occur as a consequence of product failure.



PACKAGE DIMENSIONS

44-pin Small Outline Band

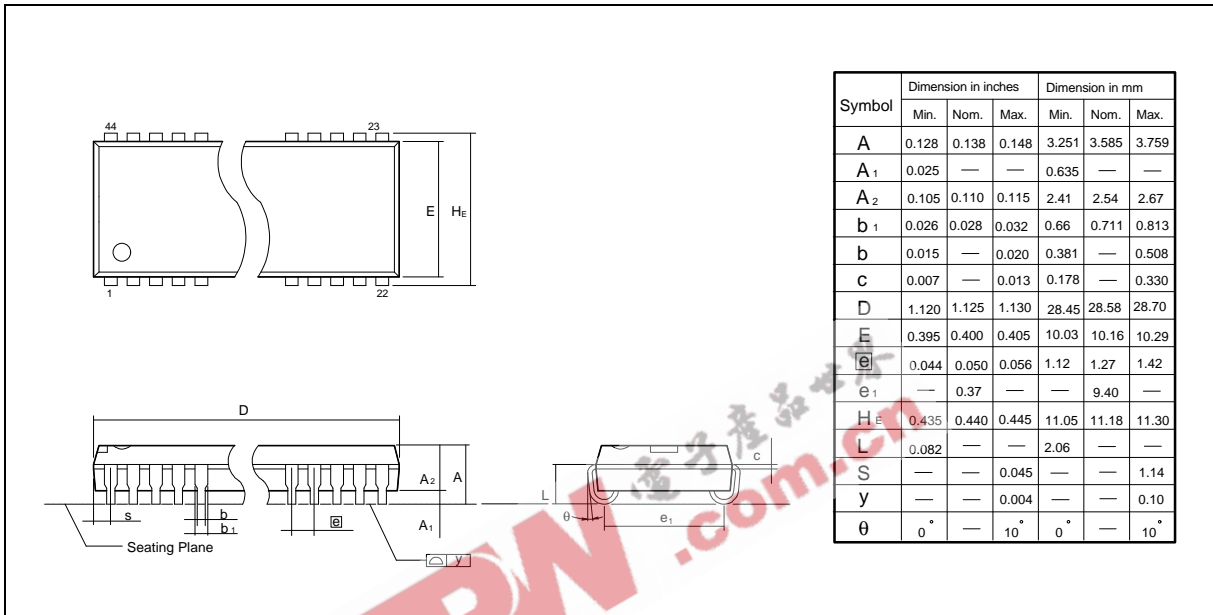

44-pin Standard Type Two TSOP

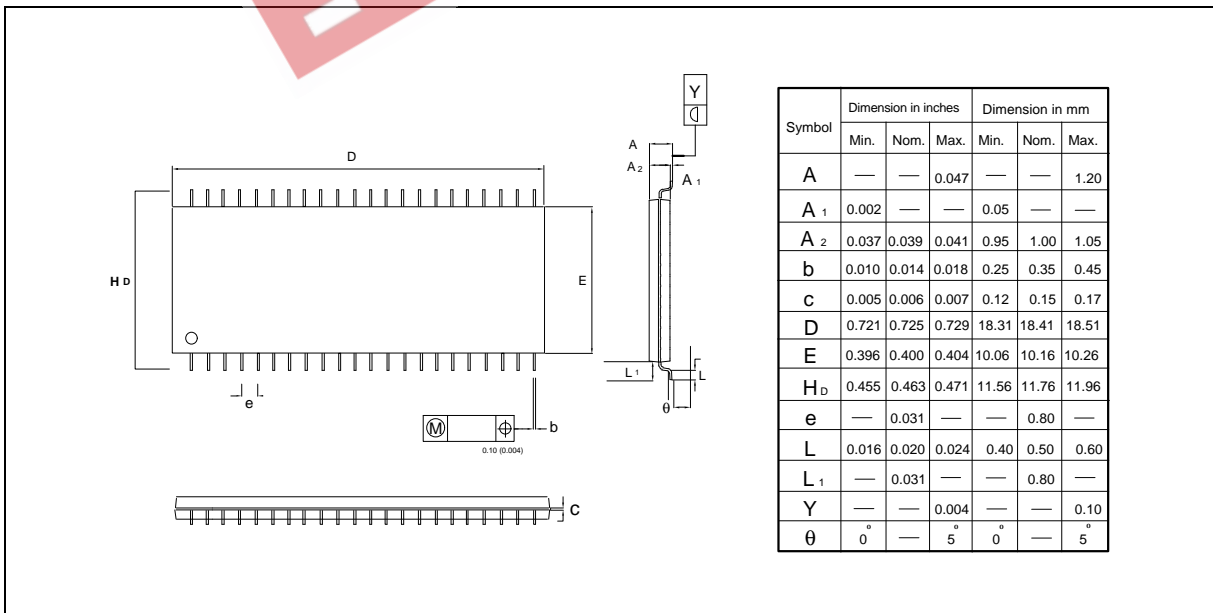



VERSION HISTORY

VERSION	DATE	PAGE	DESCRIPTION
A1	Apr. 1995		Initial Issued
A2	Feb. 1997	1, 9	Add package type two TSOP
A3	Oct. 1997	9	Correct 44-pin type two TSOP symbol "e" dimension in inches nom. from 0.006 to 0.031 in mm nom. from 0.15 to 0.80
A4	Feb. 1998	1	Modify the address sequence in pin configuration
		6	Modify the waveform "read cycle 3"
A5	May 2001	2, 4, 8	Add in Industrial operating temperature
		4, 5, 8	Add in Industrial grade type



Headquarters

No. 4, Creation Rd. III,
Science-Based Industrial Park,
Hsinchu, Taiwan
TEL: 886-3-5770066
FAX: 886-3-5792766
<http://www.winbond.com.tw/>
Voice & Fax-on-demand: 886-2-27197006

Taipei Office

11F, No. 115, Sec. 3, Min-Sheng East Rd.,
Taipei, Taiwan
TEL: 886-2-27190505
FAX: 886-2-27197502

Winbond Electronics (H.K.) Ltd.

Unit 9-15, 22F, Millennium City,
No. 378 Kwun Tong Rd;
Kowloon, Hong Kong
TEL: 852-27513100
FAX: 852-27552064

Winbond Electronics North America Corp.

Winbond Memory Lab.
Winbond Microelectronics Corp.
Winbond Systems Lab.
2727 N. First Street, San Jose,
CA 95134, U.S.A.
TEL: 408-9436666
FAX: 408-5441798

Note: All data and specifications are subject to change without notice.