



128MB- 16Mx64 SDRAM, UNBUFFERED

FEATURES

- PC100 and PC133 compatible
- Burst Mode Operation
- Auto and Self Refresh capability
- LVTTTL compatible inputs and outputs
- Serial Presence Detect with EEPROM
- Fully synchronous: All signals are registered on the positive edge of the system clock
- Programmable Burst Lengths: 1, 2, 4, 8 or Full Page
- 3.3V ± 0.3V Power Supply
- 144 pin SO-DIMM JEDEC

DESCRIPTION

The WED3DG6417V is a 16Mx64 synchronous DRAM module which consists of four 16Mx16 SDRAM components in TSOP II package, and one 2Kb EEPROM in an 8 pin TSSOP package for Serial Presence Detect which are mounted on a 144 pin SO-DIMM multilayer FR4 Substrate.

* This product is subject to change without notice.

PIN CONFIGURATIONS (FRONT SIDE/BACK SIDE)

PINOUT											
PIN	FRONT	PIN	BACK	PIN	FRONT	PIN	BACK	PIN	BACK	PIN	BACK
1	V _{SS}	2	V _{SS}	51	DQ14	52	DQ46	95	DQ21	96	DQ53
3	DQ0	4	DQ32	53	DQ15	54	DQ47	97	DQ22	98	DQ54
5	DQ1	6	DQ33	55	V _{SS}	56	V _{SS}	99	DQ23	100	DQ55
7	DQ2	8	DQ34	57	NC	58	NC	101	V _{CC}	102	V _{CC}
9	DQ3	10	DQ35	59	NC	60	NC	103	A6	104	A7
11	V _{CC}	12	V _{CC}	VOLTAGE KEY				105	A8	106	BA0
13	DQ4	14	DQ36					107	V _{SS}	108	V _{SS}
15	DQ5	16	DQ37					109	A9	110	BA1
17	DQ6	18	DQ38	61	CLK0	62	CKE0	111	A10/AP	112	A11
19	DQ7	20	DQ39	63	V _{CC}	64	V _{CC}	113	V _{CC}	114	V _{CC}
21	V _{SS}	22	V _{SS}	65	RAS#	66	CAS#	115	DQM2	116	DQM6
23	DQM0	24	DQM4	67	WE#	68	*CKE1	117	DQM3	118	DQM7
25	DQM1	26	DQM5	69	CS0#	70	A12	119	V _{SS}	120	V _{SS}
27	V _{CC}	28	V _{CC}	71	*CS1#	72	*A13	121	DQ24	122	DQ56
29	A0	30	A3	73	DNU	74	*CLK1	123	DQ25	124	DQ57
31	A1	32	A4	75	V _{SS}	76	V _{SS}	125	DQ26	126	DQ58
33	A2	34	A5	77	NC	78	NC	127	DQ27	128	DQ59
35	V _{SS}	36	V _{SS}	79	NC	80	NC	129	V _{CC}	130	V _{CC}
37	DQ8	38	DQ40	81	V _{CC}	82	V _{CC}	131	DQ28	132	DQ60
39	DQ9	40	DQ41	83	DQ16	84	DQ48	133	DQ29	134	DQ61
41	DQ10	42	DQ42	85	DQ17	86	DQ49	135	DQ30	136	DQ62
43	DQ11	44	DQ43	87	DQ18	88	DQ50	137	DQ31	138	DQ63
45	V _{CC}	46	V _{CC}	89	DQ19	90	DQ51	139	V _{SS}	140	V _{SS}
47	DQ12	48	DQ44	91	V _{SS}	92	V _{SS}	141	**SDA	142	**SCL
49	DQ13	50	DQ45	93	DQ20	94	DQ52	143	V _{CC}	144	V _{CC}

PIN NAMES

A0 – A12	Address Input (Multiplexed)
BA0-1	Select Bank
DQ0-63	Data Input/Output
CLK0	Clock Input
CKE0	Clock Enable Input
CS0#	Chip Select Input
RAS#	Row Address Strobe
CAS#	Column Address Strobe
WE#	Write Enable
DQM0-7	DQM
V _{CC}	Power Supply (3.3V)
V _{SS}	Ground
SDA	Serial Data I/O
SCL	Serial Clock
DNU	Do Not Use
NC	No Connect

* These pins are not used in this module.

** These pins should be NC in the system which does not support SPD.



FUNCTIONAL BLOCK DIAGRAM

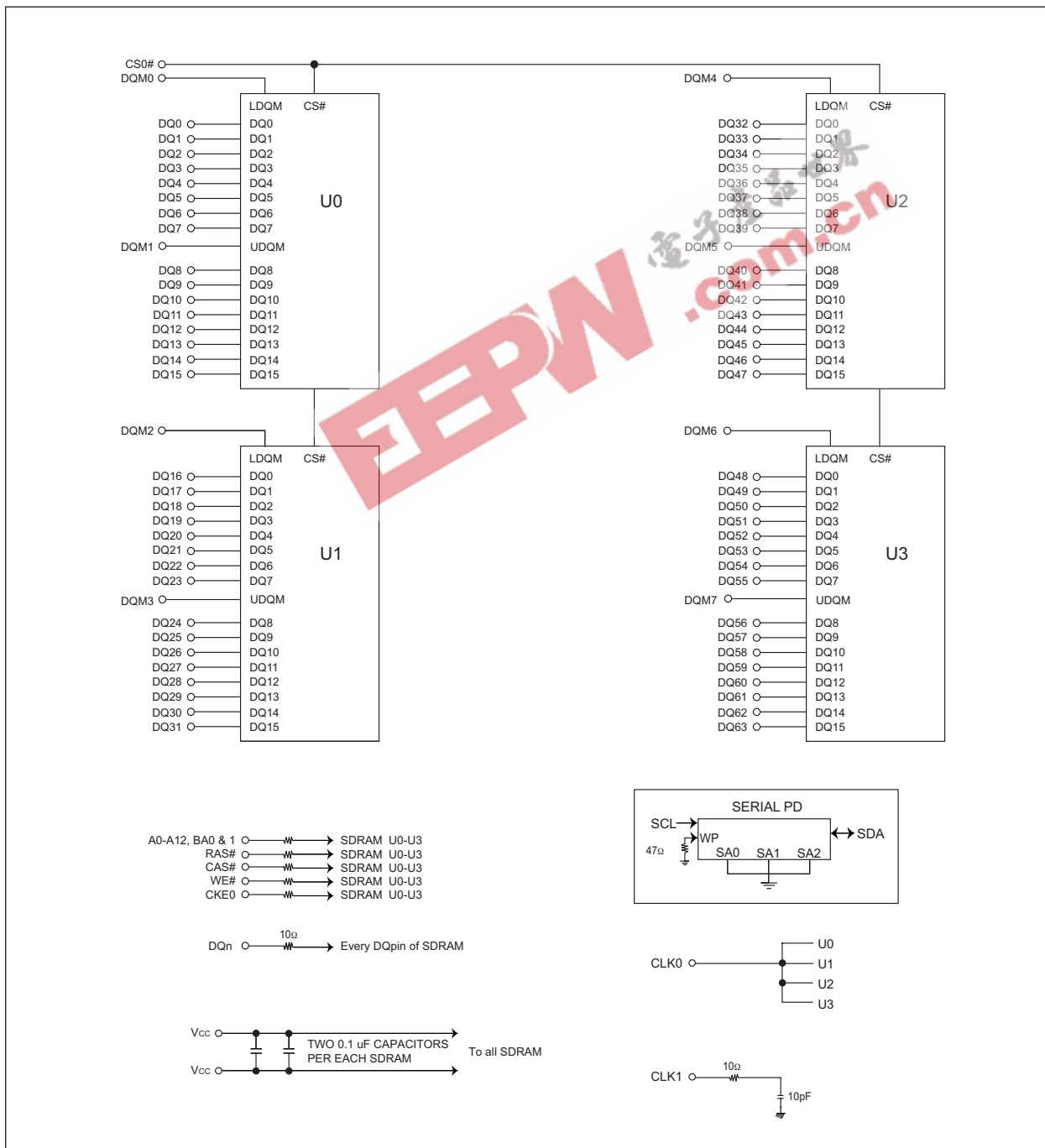



ABSOLUTE MAXIMUM RATINGS

Parameter	Symbol	Value	Units
Voltage on any pin relative to V _{SS}	V _{IN} , V _{OUT}	-1.0 ~ 4.6	V
Voltage on V _{CC} supply relative to V _{SS}	V _{CC} , V _{CCQ}	-1.0 ~ 4.6	V
Storage Temperature	T _{STG}	-55 ~ +150	°C
Power Dissipation	P _D	4	W
Short Circuit Current	I _{OS}	50	mA

Note: Permanent device damage may occur if "ABSOLUTE MAXIMUM RATINGS" are exceeded. Functional operation should be restricted to recommended operating condition. Exposure to higher than recommended voltage for extended periods of time could affect device reliability.

RECOMMENDED DC OPERATING CONDITIONS

(Voltage Referenced to: V_{SS} = 0V, T_A ≤ 0°C ≤ +70°C)

Parameter	Symbol	Min	Typ	Max	Unit	Note
Supply Voltage	V _{CC}	3.0	3.3	3.6	V	
Input High Voltage	V _{IH}	2.0	3.0	V _{CCQ} +0.3	V	1
Input Low Voltage	V _{IL}	-0.3	—	0.8	V	2
Output High Voltage	V _{OH}	2.4	—	—	V	I _{OH} = -2mA
Output Low Voltage	V _{OL}	—	—	0.4	V	I _{OL} = -2mA
Input Leakage Current	I _{LI}	-10	—	10	μA	3

Note: 1. V_{IH} (max)= 5.6V AC. The overshoot voltage duration is ≤ 3ns.
 2. V_{IL} (min)= -2.0V AC. The undershoot voltage duration is ≤ 3ns.
 3. Any input 0V ≤ V_{IN} ≤ V_{CCQ}
 Input leakage currents include Hi-Z output leakage for all bi-directional buffers with Tri-State outputs.

CAPACITANCE

(T_A = 25°C, f = 1MHz, V_{CC} = 3.3V, V_{REF}=1.4V ± 200mV)

Parameter	Symbol	Max	Unit
Input Capacitance (A0-A12)	C _{IN1}	25	pF
Input Capacitance (RAS#,CAS#,WE#)	C _{IN2}	25	pF
Input Capacitance (CKE0)	C _{IN3}	25	pF
Input Capacitance (CLK0)	C _{IN4}	18	pF
Input Capacitance (CS0#)	C _{IN5}	25	pF
Input Capacitance (DQM0-DQM7)	C _{IN6}	8	pF
Input Capacitance (BA0-BA1)	C _{IN7}	25	pF
Data Input/Output Capacitance (DQ0-DQ63)	C _{OUT}	10	pF



OPERATING CURRENT CHARACTERISTICS

($V_{CC} = 3.3V$, $T_A = 0^{\circ}C \leq +70^{\circ}C$)

Parameter	Symbol	Conditions	Version	Units	Note
			133/100		
Operating Current (One bank active)	I _{CC1}	Burst Length = 1 $t_{RC} \geq t_{RC(min)}$ $I_{OL} = 0mA$	400	mA	1
Precharge Standby Current in Power Down Mode	I _{CC2P}	$CKE \leq V_{IL(max)}$, $t_{CC} = 10ns$	10	mA	
	I _{CC2PS}	$CKE \& CLK \leq V_{IL(max)}$, $t_{CC} = \infty$	10		
Precharge Standby Current in Non-Power Down Mode	I _{CC2N}	$CKE \geq V_{IH(min)}$, $CS \geq V_{IH(min)}$, $t_{CC} = 10ns$ Input signals are charged one time during 20ns	80	mA	
	I _{CC2NS}	$CKE \geq V_{IH(min)}$, $CLK \leq V_{IL(max)}$, $t_{CC} = \infty$ Input signals are stable	40		
Active Standby Current in Power-Down Mode	I _{CC3P}	$CKE \geq V_{IL(max)}$, $t_{CC} = 10ns$	25	mA	
	I _{CC3PS}	$CKE \& CLK \leq V_{IL(max)}$, $t_{CC} = \infty$	25		
Active Standby Current in Non-Power Down Mode	I _{CC3N}	$CKE \geq V_{IH(min)}$, $CS \geq V_{IH(min)}$, $t_{CC} = 10ns$ Input signals are changed one time during 20ns	120	mA	
	I _{CC3NS}	$CKE \geq V_{IH(min)}$, $CLK \leq V_{IL(max)}$, $t_{CC} = \infty$ Input signals are stable	100		
Operating Current (Burst mode)	I _{CC4}	$I_O = mA$ Page burst 4 Banks activated $t_{CCD} = 2CLK$	560	mA	1
Refresh Current	I _{CC5}	$t_{RC} \geq t_{RC(min)}$	800	mA	2
Self Refresh Current	I _{CC6}	$CKE \leq 0.2V$	15	mA	

- Notes: 1. Measured with outputs open.
 2. Refresh period is 64ms.
 3. Unless otherwise noticed, input swing level is CMOS ($V_{IH}/V_{IL} = V_{CC}/V_{SS}$)



PACKAGE DIMENSIONS FOR D1

Ordering Information	Speed	CAS Latency	Height*
WED3DG6417V10D1	100MHz	CL=2	27.94 (1.10")
WED3DG6417V7D1	133MHz	CL=2	27.94 (1.10")
WED3DG6417V75D1	133MHz	CL=3	27.94 (1.10")

Note: For industrial temperature range product, add an "I" to the end of the part number.

PACKAGE DIMENSIONS FOR D1

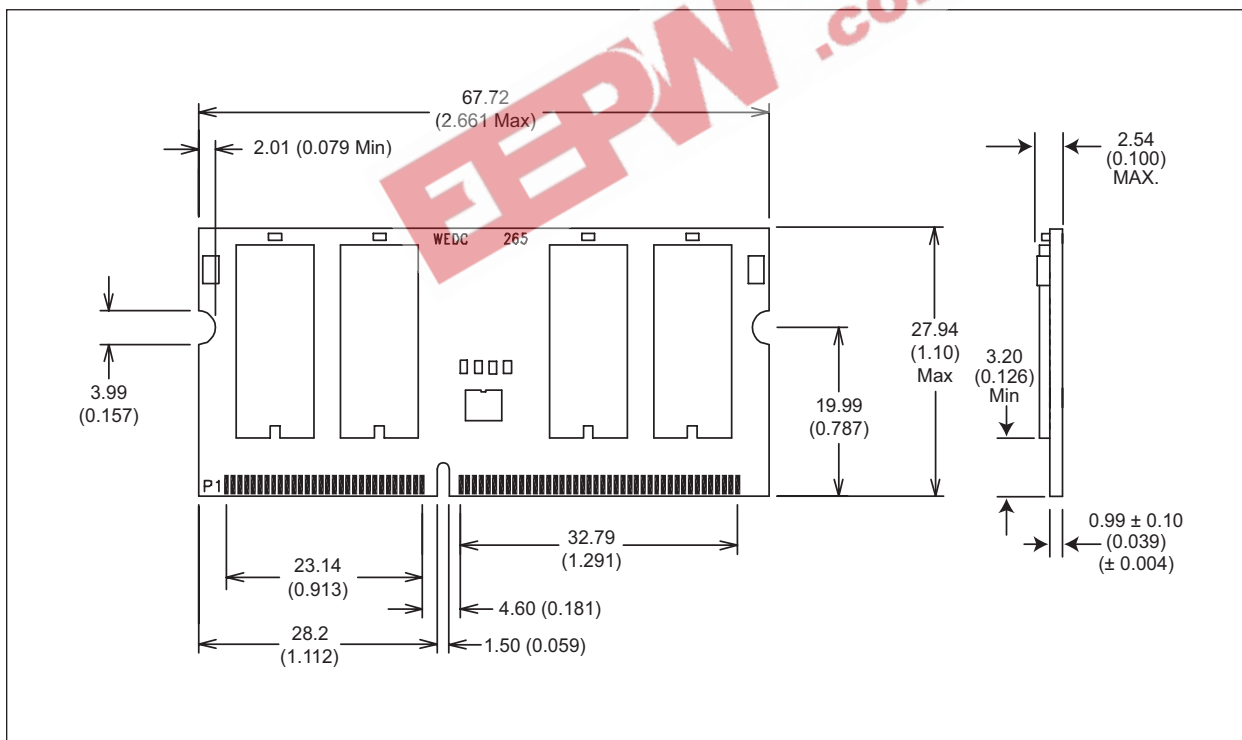

* All Dimensions are in millimeters and (inches).



Document Title

128MB - 16Mx64 SDRAM, UNBUFFERED

Revision History

Rev #	History	Release Date	Status
Rev 0	Created Datasheet	6-4-03	Advanced
Rev 1	1.1 Updated Datasheet	5-04	Final

