



512MB- 64Mx64 SDRAM, UNBUFFERED W/PLL

FEATURES

- PC100 and PC133 compatible
- Burst Mode Operation
- Auto and Self Refresh capability
- LVTTTL compatible inputs and outputs
- Serial Presence Detect with EEPROM
- Fully synchronous: All signals are registered on the positive edge of the system clock
- Programmable Burst Lengths: 1, 2, 4, 8 or Full Page
- 3.3V ± 0.3V Power Supply
- 144 Pin SO-DIMM JEDEC

DESCRIPTION

The W3DG6464V is a 64Mx64 synchronous DRAM module which consists of eight 64Mx8 stack SDRAM components in TSOP II package, and one 2Kb EEPROM in an 8 pin TSSOP package for Serial Presence Detect which are mounted on a 144 pin SO-DIMM multilayer FR4 Substrate.

*This product is subject to change without notice.

PIN CONFIGURATIONS (FRONT SIDE/BACK SIDE)

PINOUT											
PIN	FRONT	PIN	BACK	PIN	FRONT	PIN	BACK	PIN	BACK	PIN	BACK
1	V _{ss}	2	V _{ss}	49	DQ13	50	DQ45	97	DQ22	98	DQ54
3	DQ0	4	DQ32	51	DQ14	52	DQ46	99	DQ23	100	DQ55
5	DQ1	6	DQ33	53	DQ15	54	DQ47	101	V _{cc}	102	V _{cc}
7	DQ2	8	DQ34	55	V _{ss}	56	V _{ss}	103	A6	104	A7
9	DQ3	10	DQ35	57	NC	58	NC	105	A8	106	BA0
11	V _{cc}	12	V _{cc}	59	NC	60	NC	107	V _{ss}	108	V _{ss}
13	DQ4	14	DQ36	61	CK0	62	CKE0	109	A9	110	BA1
15	DQ5	16	DQ37	63	V _{cc}	64	V _{cc}	111	A10	112	A11
17	DQ6	18	DQ38	65	RAS#	66	CAS#	113	V _{cc}	114	V _{cc}
19	DQ7	20	DQ39	67	WE#	68	CKE1	115	DQMB2	116	DQMB6
21	V _{ss}	22	V _{ss}	69	CS0#	70	A12	117	DQMB3	118	DQMB7
23	DQM0	24	DQM4	71	CS1#	72	NC	119	V _{ss}	120	V _{ss}
25	DQM1	26	DQM5	73	NC	74	NC	121	DQ24	122	DQ56
27	V _{cc}	28	V _{cc}	75	V _{ss}	76	V _{ss}	123	DQ25	124	DQ57
29	A0	30	A3	77	NC	78	NC	125	DQ26	126	DQ58
31	A1	32	A4	79	NC	80	NC	127	DQ27	128	DQ59
33	A2	34	A5	81	V _{cc}	82	V _{cc}	129	V _{cc}	130	V _{cc}
35	V _{ss}	36	V _{ss}	83	DQ16	84	DQ48	131	DQ28	132	DQ60
37	DQ8	38	DQ40	85	DQ17	86	DQ49	133	DQ29	134	DQ61
39	DQ9	40	DQ41	87	DQ18	88	DQ50	135	DQ30	136	DQ62
41	DQ10	42	DQ42	89	DQ19	90	DQ51	137	DQ31	138	DQ63
43	DQ11	44	DQ43	91	V _{ss}	92	V _{ss}	139	V _{ss}	140	V _{ss}
45	V _{cc}	46	V _{cc}	93	DQ20	94	DQ52	141	SDA	142	SCL
47	DQ12	48	DQ44	95	DQ21	96	DQ53	143	V _{cc}	144	V _{cc}

PIN NAMES

A0 – A12	Address Input (Multiplexed)
BA0-1	Select Bank
DQ0-63	Data Input/Output
CK0	Clock Input
CKE0, CKE1	Clock Enable Input
CS0#, CS1#	Chip Select Input
RAS#	Row Address Strobe
CAS#	Column Address Strobe
WE#	Write Enable
DQM0-7	DQM
V _{cc}	Power Supply (3.3V)
V _{ss}	Ground
SDA	Serial Data I/O
SCL	Serial Clock
DNU	Do Not Use
NC	No Connect

** These pins should be NC in the system which does not support SPD.



FUNCTIONAL BLOCK DIAGRAM

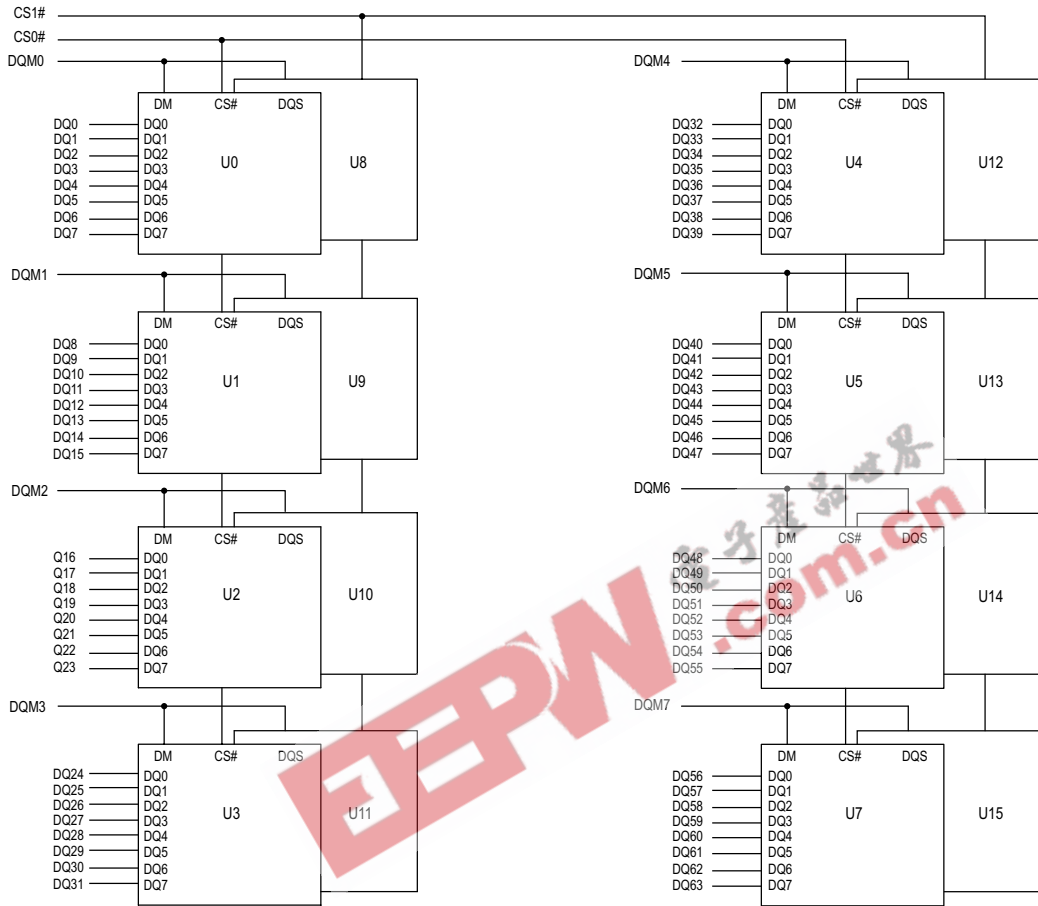

- BA0,BA1 → U0-U15
- A0-A12 → U0-U15
- RAS# → U0-U15
- CAS# → U0-U15
- CKE0 → U0-U7
- CKE1 → U9-U15
- WE# → U0-U15

NOTE: All resistor values are 22 ohms unless otherwise specified.

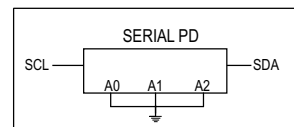
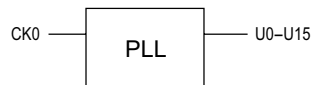



ABSOLUTE MAXIMUM RATINGS

Parameter	Symbol	Value	Units
Voltage on any pin relative to Vss	V _{IN} , V _{OUT}	-1.0 ~ 4.6	V
Voltage on Vcc supply relative to Vss	V _{CC} , V _{CCQ}	-1.0 ~ 4.6	V
Storage Temperature	T _{STG}	-55 ~ +150	°C
Power Dissipation	P _D	16	W
Short Circuit Current	I _{OS}	50	mA

Note: Permanent device damage may occur if "ABSOLUTE MAXIMUM RATINGS" are exceeded.
 Functional operation should be restricted to recommended operating condition.
 Exposure to higher than recommended voltage for extended periods of time could affect device reliability.

RECOMMENDED DC OPERATING CONDITIONS

(Voltage Referenced to: Vss = 0V, T_A = 0°C to +70°C)

Parameter	Symbol	Min	Typ	Max	Unit	Note
Supply Voltage	V _{CC}	3.0	3.3	3.6	V	
Input High Voltage	V _{IH}	2.0	3.0	V _{CCQ} +0.3	V	1
Input Low Voltage	V _{IL}	-0.3	—	0.8	V	2
Output High Voltage	V _{OH}	2.4	—	—	V	I _{OH} = -2mA
Output Low Voltage	V _{OL}	—	—	0.4	V	I _{OL} = -2mA
Input Leakage Current	I _{LI}	-10	—	10	μA	3

Note: 1. V_{IH} (max) = 5.6V AC. The overshoot voltage duration is ≤ 3ns.
 2. V_{IL} (min) = -2.0V AC. The undershoot voltage duration is ≤ 3ns.
 3. Any input 0V ≤ V_{IN} ≤ V_{CCQ}
 Input leakage currents include Hi-Z output leakage for all bi-directional buffers with Tri-State outputs.

CAPACITANCE

(T_A = 23°C, f = 1MHz, V_{CC} = 3.3V, V_{REF} = 1.4V ± 200mV)

Parameter	Symbol	Max	Unit
Input Capacitance (A0-A12)	C _{IN1}	15	pF
Input Capacitance (RAS#,CAS#,WE#)	C _{IN2}	15	pF
Input Capacitance (CKE0)	C _{IN3}	15	pF
Input Capacitance (CK0, CK1)	C _{IN4}	20	pF
Input Capacitance (CS0#)	C _{IN5}	15	pF
Input Capacitance (DQM0-DQM7)	C _{IN6}	15	pF
Input Capacitance (BA0-BA1)	C _{IN7}	15	pF
Data Input/Output Capacitance (DQ0-DQ63)	C _{OUT}	22	pF
Data Input/Output Capacitance (CB0-7)	C _{OUT1}	22	pF



OPERATING CURRENT CHARACTERISTICS

($V_{CC} = 3.3V$, $T_A = 0^{\circ}C$ to $+70^{\circ}C$)

Parameter	Symbol	Conditions	Version		Units	Note
			133	100		
Operating Current (One bank active)	I _{CC1}	Burst Length = 1 $t_{RC} \geq t_{RC(min)}$ $I_{OL} = 0mA$	960	880	mA	1
Precharge Standby Current in Power Down Mode	I _{CC2P}	$CKE \leq V_{IL(max)}$, $t_{CC} = 10ns$	40		mA	
	I _{CC2PS}	$CKE \& CK \leq V_{IL(max)}$, $t_{CC} = \infty$	40			
Precharge Standby Current in Non-Power Down Mode	I _{CC2N}	$CKE \geq V_{IH(min)}$, $CS \geq V_{IH(min)}$, $t_{CC} = 10ns$ Input signals are charged one time during 20ns	320		mA	
	I _{CC2NS}	$CKE \geq V_{IH(min)}$, $CK \leq V_{IL(max)}$, $t_{CC} = \infty$ Input signals are stable	160			
Active Standby Current in Power-Down Mode	I _{CC3P}	$CKE \geq V_{IL(max)}$, $t_{CC} = 10ns$	65		mA	
	I _{CC3PS}	$CKE \& CK \leq V_{IL(max)}$, $t_{CC} = \infty$	65			
Active Standby Current in Non-Power Down Mode	I _{CC3N}	$CKE \geq V_{IH(min)}$, $CS \geq V_{IH(min)}$, $t_{CC} = 10ns$ Input signals are changed one time during 20ns	400		mA	
	I _{CC3NS}	$CKE \geq V_{IH(min)}$, $CK \leq V_{IL(max)}$, $t_{CC} = \infty$ Input signals are stable	280			
Operating Current (Burst mode)	I _{CC4}	$I_O = mA$ Page burst 4 Banks activated $t_{CCD} = 2CK$	1,120	1,040	mA	1
Refresh Current	I _{CC5}	$t_{RC} \geq t_{RC(min)}$	1,920	1,680	mA	2
Self Refresh Current	I _{CC6}	$CKE \leq 0.2V$	50	50	mA	

- Notes: 1. Measured with outputs open.
 2. Refresh period is 64ms.
 3. Unless otherwise noticed, input swing level is CMOS ($V_{IH}/V_{IL} = V_{CC}/V_{SSC}$)



Ordering Information	Speed	CAS Latency
W3DG6464V10D1	100MHz	CL=2
W3DG6464V7D1	133MHz	CL=2
W3DG6464V75D1	133MHz	CL=3

Note: For industrial temperature range product, add an "I" to the end of the part number.

PACKAGE DIMENSIONS

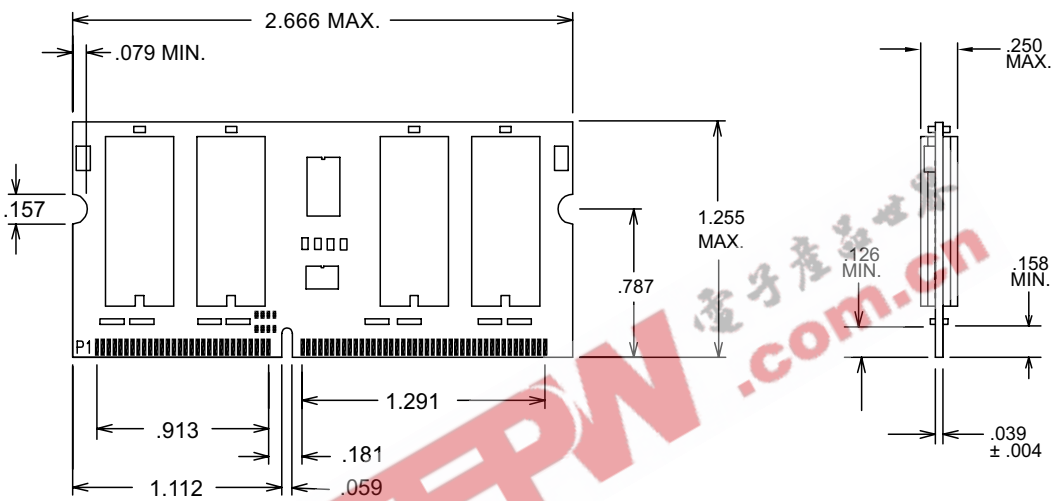

ALL DIMENSIONS ARE IN INCHES