



512Kx8 MONOLITHIC SRAM

FEATURES

- Access Times 15, 17, 20ns
- Revolutionary, Center Power/Ground Pinout JEDEC Approved
 - 36 lead Ceramic SOJ (Package 100)
 - 36 lead Ceramic Flat Pack (Package 226)
- Evolutionary, Corner Power/Ground Pinout JEDEC Approved
 - 32 pin Ceramic DIP (Package 300)
 - 32 lead Ceramic SOJ (Package 101)
 - 32 lead Ceramic Flat Pack (Package 220)
- Low Voltage Operation:
 - 3.3V ± 10% Power Supply
- BiCMOS:
 - Radiation Tolerant with Epitaxial Layer Die
- Commercial and Industrial Temperature Ranges
- TTL Compatible Inputs and Outputs
- Fully Static Operation:
 - No clock or refresh required.
- Three State Output

This product is subject to change without notice.

REVOLUTIONARY PINOUT

36 FLAT PACK
36 CSOJ

TOP VIEW

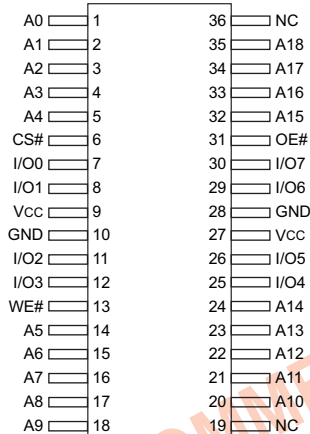

EVOLUTIONARY PINOUT

32 DIP
32 CSOJ (DE)
32 FLAT PACK (FE)

TOP VIEW

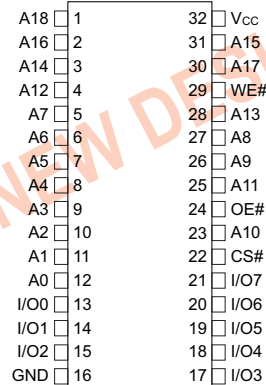

PIN DESCRIPTION

| | |
|--------|-------------------|
| A0-18 | Address Inputs |
| I/O0-7 | Data Input/Output |
| CS# | Chip Select |
| OE# | Output Enable |
| WE# | Write Enable |
| Vcc | Power Supply |
| GND | Ground |



ABSOLUTE MAXIMUM RATINGS

| Parameter | Symbol | Min | Max | Unit |
|-----------------------------|------------------|------|------|------|
| Operating Temperature | T _A | -40 | +85 | °C |
| Storage Temperature | T _{STG} | -65 | +150 | °C |
| Signal Voltage Range to GND | V _G | -0.5 | 4.6 | V |
| Junction Temperature | T _J | | 150 | °C |
| Supply Voltage | V _{CC} | -0.5 | 4.6 | V |

TRUTH TABLE

| CS# | OE# | WE# | MODE | DATA I/O | POWER |
|-----|-----|-----|-------------|----------|---------|
| H | X | X | Standby | High Z | Standby |
| L | L | H | Read | Data Out | Active |
| L | X | L | Write | Data In | Active |
| L | H | H | Out Disable | High Z | Active |

RECOMMENDED OPERATING CONDITIONS

| Parameter | Symbol | Min | Max | Unit |
|-----------------------|-----------------|------|-----------------------|------|
| Supply Voltage | V _{CC} | 3.0 | 3.6 | V |
| Input High Voltage | V _{IH} | 2.2 | V _{CC} + 0.3 | V |
| Input Low Voltage | V _{IL} | -0.3 | +0.8 | V |
| Operating Temperature | T _A | -40 | +85 | °C |

CAPACITANCE

T_A = +25°C

| Parameter | Symbol | Conditions | Max | Unit |
|--------------------|------------------|-------------------------------------|-----|------|
| Input capacitance | C _{IN} | V _{IN} = 0 V, f = 1.0 MHz | 12 | pF |
| Output capacitance | C _{OUT} | V _{OUT} = 0 V, f = 1.0 MHz | 12 | pF |

This parameter is guaranteed by design but not tested.

DC CHARACTERISTICS - CMOS COMPATIBLE

V_{CC} = 3.3V, GND = 0V, -40°C ≤ T_A ≤ 85°C

| Parameter | Symbol | Conditions | Min | Max | Unit |
|--------------------------|-----------------|---|-----|-----|------|
| Input Leakage Current | I _{LI} | V _{CC} = 5.5, V _{IN} = GND to V _{CC} | | 10 | μA |
| Output Leakage Current | I _{LO} | CS# = V _{IH} , OE# = V _{IH} , V _{OUT} = GND to V _{CC} | | 10 | μA |
| Operating Supply Current | I _{CC} | CS# = V _{IH} , OE# = V _{IH} , f = 5MHz, V _{CC} = 5.5 | | 120 | mA |
| Standby Current | I _{SB} | CS# = V _{IH} , OE# = V _{IH} , f = 5MHz, V _{CC} = 5.5 | | 15 | mA |
| Output Low Voltage | V _{OL} | I _{OL} = 8mA | | 0.4 | V |
| Output High Voltage | V _{OH} | I _{OH} = -4.0mA | 2.4 | | V |

NOTE: DC test conditions: V_{IH} = V_{CC} - 0.3V, V_{IL} = 0.3V



AC CHARACTERISTICS

V_{CC} = 3.3V, GND = 0V, -40°C ≤ T_A ≤ 85°C

| Parameter Read Cycle | Symbol | -15 | | -17 | | -20 | | Unit |
|------------------------------------|-------------------------------|-----|-----|-----|-----|-----|-----|------|
| | | Min | Max | Min | Max | Min | Max | |
| Read Cycle Time | t _{RC} | 15 | | 17 | | 20 | | ns |
| Address Access Time | t _{AA} | | 15 | | 17 | | 20 | ns |
| Output Hold from Address Change | t _{OH} | 0 | | 0 | | 0 | | ns |
| Chip Select Access Time | t _{ACS} | | 15 | | 17 | | 20 | ns |
| Output Enable to Output Valid | t _{OE} | | 7 | | 8 | | 10 | ns |
| Chip Select to Output in Low Z | t _{CLZ} ¹ | 2 | | 2 | | 2 | | ns |
| Output Enable to Output in Low Z | t _{OLZ} ¹ | 0 | | 0 | | 0 | | ns |
| Chip Disable to Output in High Z | t _{CHZ} ¹ | | 7 | | 8 | | 10 | ns |
| Output Disable to Output in High Z | t _{OHZ} ¹ | | 7 | | 8 | | 10 | ns |

1. This parameter is guaranteed by design but not tested.

AC CHARACTERISTICS

V_{CC} = 3.3V, GND = 0V, -40°C ≤ T_A ≤ 85°C

| Parameter Write Cycle | Symbol | -15 | | -17 | | -20 | | Unit |
|----------------------------------|-------------------------------|-----|-----|-----|-----|-----|-----|------|
| | | Min | Max | Min | Max | Min | Max | |
| Write Cycle Time | t _{WC} | 15 | | 17 | | 20 | | ns |
| Chip Select to End of Write | t _{CW} | 10 | | 12 | | 14 | | ns |
| Address Valid to End of Write | t _{AW} | 10 | | 12 | | 14 | | ns |
| Data Valid to End of Write | t _{DW} | 8 | | 9 | | 10 | | ns |
| Write Pulse Width | t _{WP} | 12 | | 14 | | 14 | | ns |
| Address Setup Time | t _{AS} | 0 | | 0 | | 0 | | ns |
| Address Hold Time | t _{AH} | 0 | | 0 | | 0 | | ns |
| Output Active from End of Write | t _{OW} ¹ | 2 | | 3 | | 3 | | ns |
| Write Enable to Output in High Z | t _{WHZ} ¹ | | 8 | | 8 | | 9 | ns |
| Data Hold Time | t _{DH} | 0 | | 0 | | 0 | | ns |

1. This parameter is guaranteed by design but not tested.

AC TEST CIRCUIT

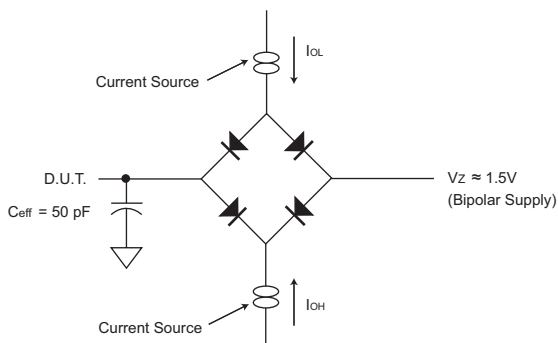

AC TEST CONDITIONS

| Parameter | Typ | Unit |
|----------------------------------|--|------|
| Input Pulse Levels | V _{IL} = 0, V _{IH} = 2.5 | V |
| Input Rise and Fall | 5 | ns |
| Input and Output Reference Level | 1.5 | V |
| Output Timing Reference Level | 1.5 | V |

Notes:

V_Z is programmable from -2V to +7V.
 I_{OL} & I_{OH} programmable from 0 to 16mA.
 Tester Impedance Z₀ = 75Ω.
 V_Z is typically the midpoint of V_{OH} and V_{OL}.
 I_{OL} & I_{OH} are adjusted to simulate a typical resistive load circuit.
 ATE tester includes jig capacitance.



TIMING WAVEFORM - READ CYCLE

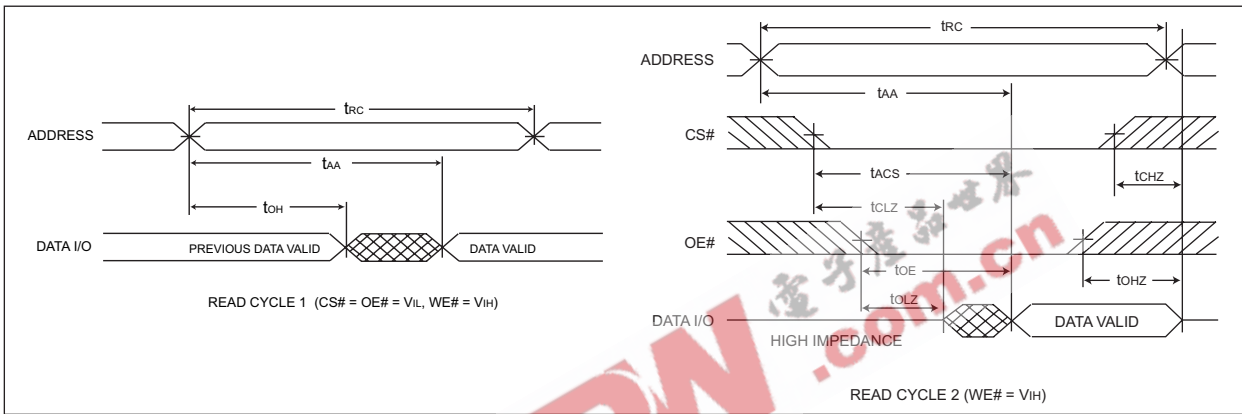

WRITE CYCLE - WE# CONTROLLED

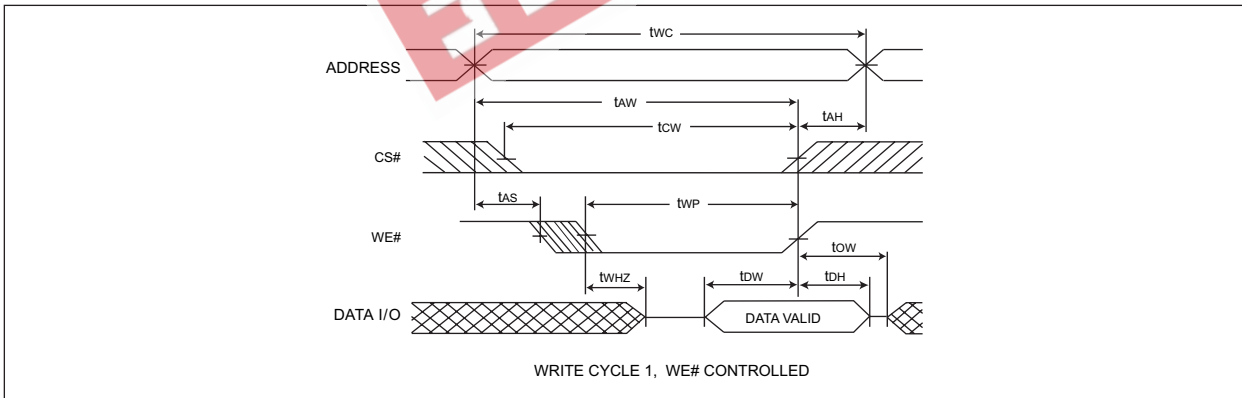

WRITE CYCLE - CS# CONTROLLED

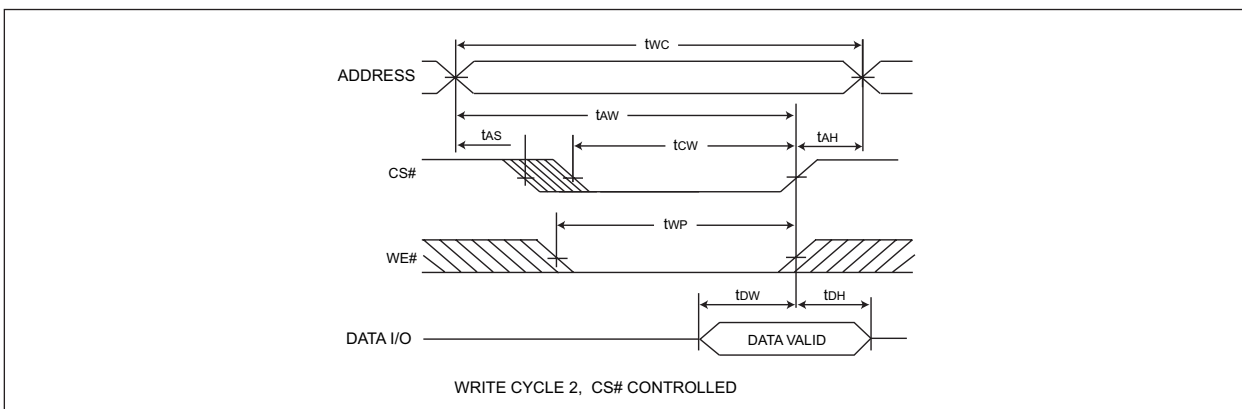



PACKAGE 100: 36 LEAD, CERAMIC SOJ

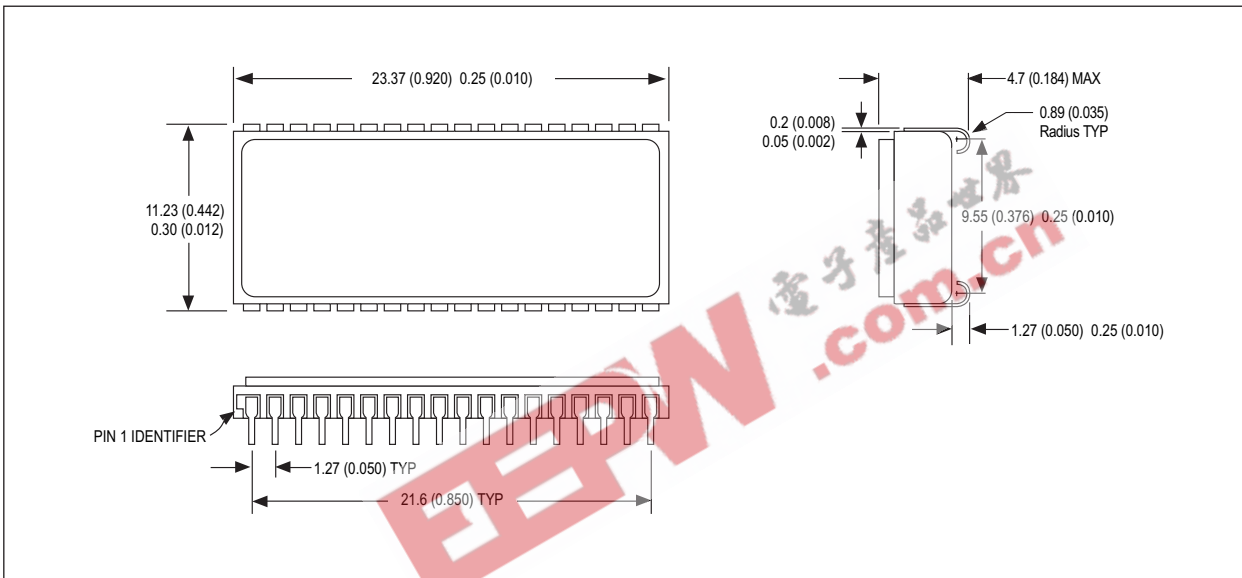

ALL LINEAR DIMENSIONS ARE MILLIMETERS AND PARENTHETICALLY IN INCHES

PACKAGE 101: 32 LEAD, CERAMIC SOJ

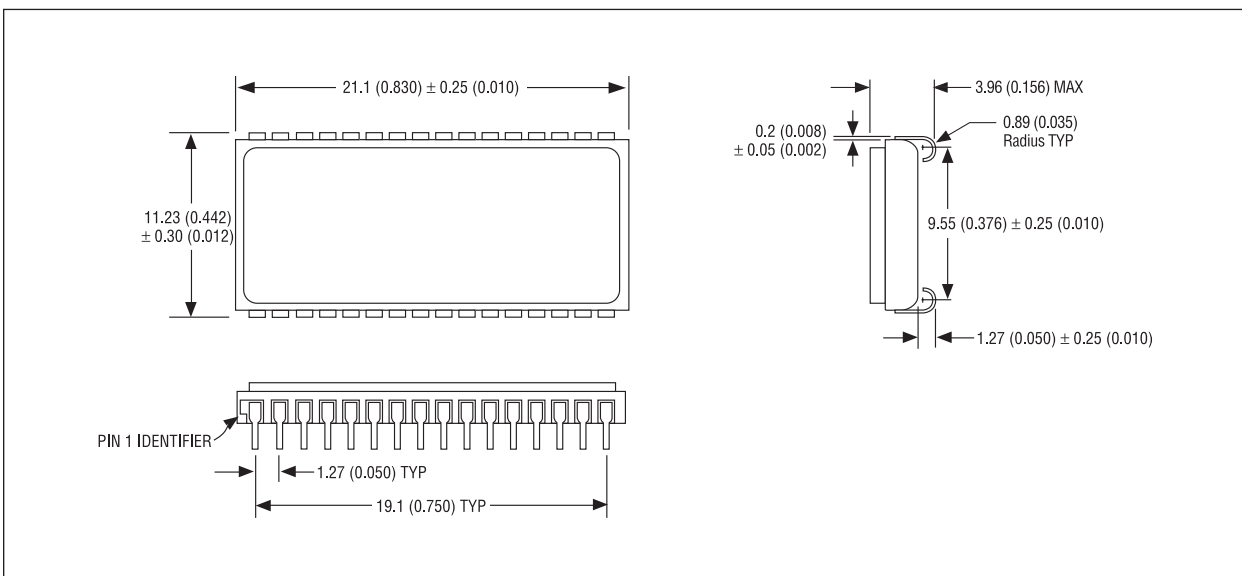

ALL LINEAR DIMENSIONS ARE MILLIMETERS AND PARENTHETICALLY IN INCHES



PACKAGE 220: 32 LEAD, CERAMIC FLAT PACK

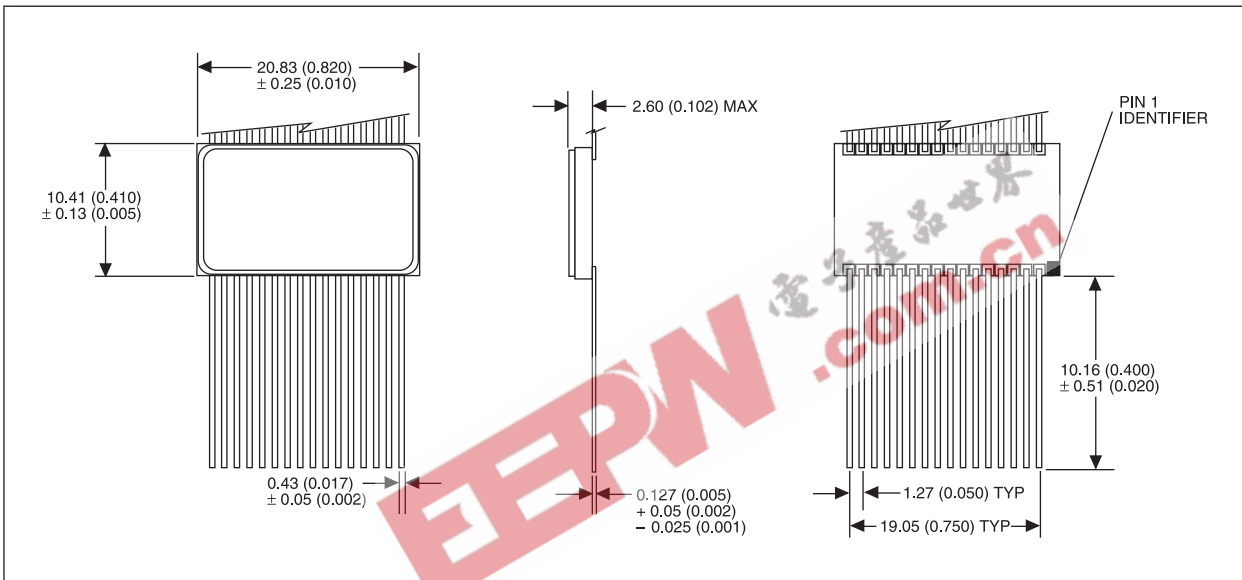

ALL LINEAR DIMENSIONS ARE MILLIMETERS AND PARENTHETICALLY IN INCHES

PACKAGE 226: 36 LEAD, CERAMIC FLAT PACK

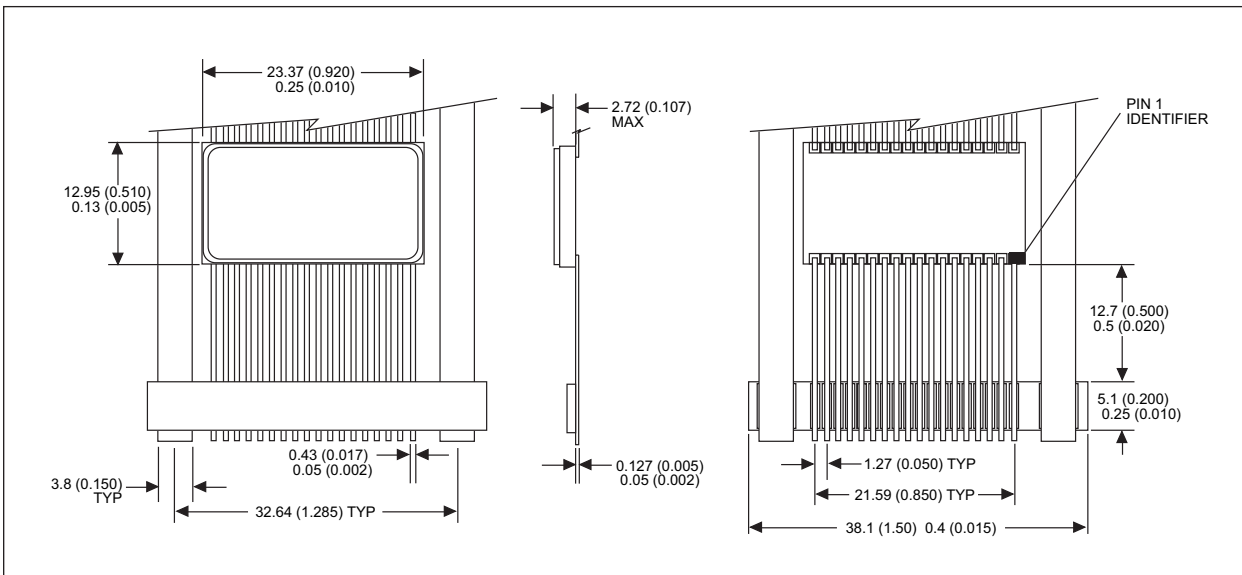

ALL LINEAR DIMENSIONS ARE MILLIMETERS AND PARENTHETICALLY IN INCHES



PACKAGE 300: 32 PIN, CERAMIC DIP, SINGLE CAVITY SIDE BRAZED

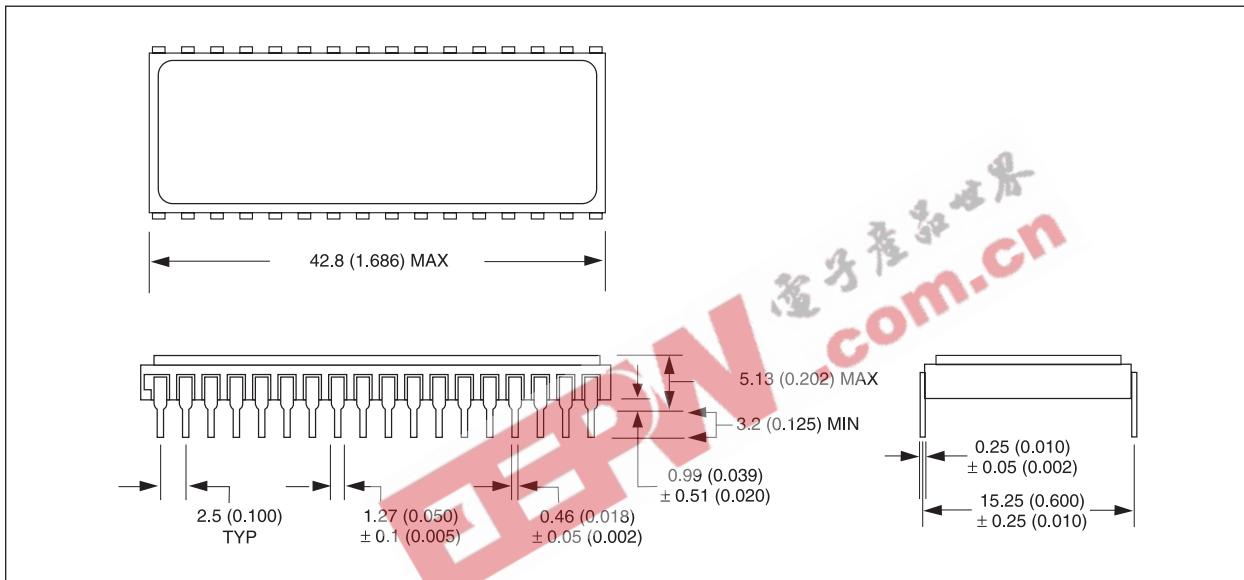

ALL LINEAR DIMENSIONS ARE MILLIMETERS AND PARENTHETICALLY IN INCHES



ORDERING INFORMATION

W M S 512K 8 B V - XXX X X E X

LEAD FINISH:

- Blank = Gold plated leads
- A = Solder dip leads

E = Epitaxial Layer

DEVICE GRADE:

- I = Industrial -40°C to +85°C
- C = Commercial 0°C to +70°C

PACKAGE:

- C = 32 Pin Ceramic .600" DIP (Package 300)
- DE = 32 Lead Ceramic SOJ (Package 101) Evolutionary
- DJ = 36 Lead Ceramic SOJ (Package 100)
- F = 36 Lead Ceramic Flat Pack (Package 226)
- FE = 32 Lead Ceramic Flat Pack (Package 220)

ACCESS TIME (ns)

Low Voltage Supply 3.3V ± 10%

BiCMOS

ORGANIZATION, 512K x 8

SRAM

MONOLITHIC

WHITE ELECTRONIC DESIGNS CORP.