



128Kx8 MONOLITHIC SRAM, SMD 5962-96691

FEATURES

- Access Times 70, 85, 100, 120ns
- Revolutionary, Center Power/Ground Pinout JEDEC Approved
 - 32 lead Ceramic SOJ (Package 101)
- Evolutionary, Corner Power/Ground Pinout JEDEC Approved
 - 32 pin Ceramic DIP (Package 300)
 - 32 lead Ceramic SOJ (Package 101)
 - 32 lead Ceramic Flat Pack (Package 206)
- MIL-STD-883 Compliant Devices Available
- Commercial, Industrial and Military Temperature Range
- 5 Volt Power Supply
- Low Power CMOS
- 2V Data Retention Devices Available (Low Power Version)
- TTL Compatible Inputs and Outputs

REVOLUTIONARY PINOUT

32 CSOJ (DR)

TOP VIEW

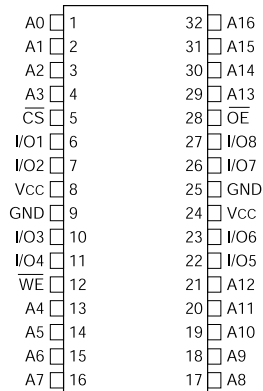

EVOLUTIONARY PINOUT

32 DIP (C)
32 CSOJ (DE)
32 FLATPACK (FE)

TOP VIEW

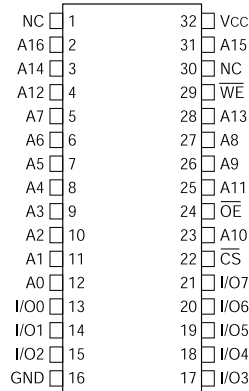

PIN DESCRIPTION

A0-16	Address Inputs
I/O0-7	Data Input/Output
\overline{CS}	Chip Select
\overline{OE}	Output Enable
\overline{WE}	Write Enable
Vcc	+5.0V Power
GND	Ground



ABSOLUTE MAXIMUM RATINGS

Parameter	Symbol	Min	Max	Unit
Operating Temperature	T _A	-55	+125	°C
Storage Temperature	T _{STG}	-65	+150	°C
Signal Voltage Relative to GND	V _G	-0.5	V _{CC} +0.5	V
Junction Temperature	T _J		150	°C
Supply Voltage	V _{CC}	-0.5	7.0	V

TRUTH TABLE

\overline{CS}	\overline{OE}	\overline{WE}	Mode	Data I/O	Power
H	X	X	Standby	High Z	Standby
L	L	H	Read	Data Out	Active
L	H	H	Out Disable	High Z	Active
L	X	L	Write	Data In	Active

RECOMMENDED OPERATING CONDITIONS

Parameter	Symbol	Min	Max	Unit
Supply Voltage	V _{CC}	4.5	5.5	V
Input High Voltage	V _{IH}	2.2	V _{CC} + 0.3	V
Input Low Voltage	V _{IL}	-0.5	+0.8	V

**CAPACITANCE
(TA = +25°C)**

Parameter	Symbol	Condition	Package	Max	Unit
Input capacitance	C _{IN}	V _{IN} = 0V, f = 1.0MHz	32 Pin CSOJ, DIP, Flat Pack Evolutionary	12	pF
			32 Pin CSOJ Revolutionary	20	pF
Output capacitance	C _{OUT}	V _{OUT} = 0V, f = 1.0MHz	32 Pin CSOJ, DIP, Flat Pack Evolutionary	12	pF
			32 Pin CSOJ Revolutionary	20	pF

This parameter is guaranteed by design but not tested.

**DC CHARACTERISTICS
(VCC = 5.0V, GND = 0V, TA = -55°C TO +125°C)**

Parameter	Sym	Conditions	-70		-85		-100		-120		Units
			Min	Max	Min	Max	Min	Max	Min	Max	
Input Leakage Current	I _{LI}	V _{CC} = 5.5, V _{IN} = GND to V _{CC}		10		10		10		10	μA
Output Leakage Current	I _{LO}	$\overline{CS} = V_{IH}, \overline{OE} = V_{IH}, V_{OUT} = GND \text{ to } V_{CC}$		10		10		10		10	μA
Operating Supply Current	I _{CC}	$\overline{CS} = V_{IH}, \overline{OE} = V_{IH}, f = 5\text{MHz}, V_{CC} = 5.5$		30		30		30		30	mA
Standby Current	I _{SB}	$\overline{CS} = V_{IH}, \overline{OE} = V_{IH}, f = 5\text{MHz}, V_{CC} = 5.5$		5		5		5		5	mA
Output Low Voltage	V _{OL}	I _{OL} = 2.1mA, V _{CC} = 4.5		0.4		0.4		0.4		0.4	V
Output High Voltage	V _{OH}	I _{OH} = -1.0mA, V _{CC} = 4.5	2.4		2.4		2.4		2.4		V

NOTE: DC test conditions: V_{IH} = V_{CC} - 0.3V, V_{IL} = 0.3V

**DATA RETENTION CHARACTERISTICS
(TA = -55°C TO +125°C)**

Parameter	Symbol	Conditions	-70		-85		-100		-120		Units
			Min	Max	Min	Max	Min	Max	Min	Max	
Data Retention Supply Voltage	V _{DR}	$\overline{CS} \geq V_{CC} - 0.2V$	2.0	5.5	2.0	5.5	2.0	5.5	2.0	5.5	V
Data Retention Current	I _{CCDR1}	V _{CC} = 3V		1		1		1		1	mA



AC CHARACTERISTICS
(VCC = 5.0V, TA = -55°C To +125°C)

Parameter	Symbol	-70		-85		-100		-120		Units
		Min	Max	Min	Max	Min	Max	Min	Max	
Read Cycle										
Read Cycle Time	t _{RC}	70		85		100		120		ns
Address Access Time	t _{AA}		70		85		100		120	ns
Output Hold from Address Change	t _{OH}	3		3		3		3		ns
Chip Select Access Time	t _{ACS}		70		85		100		120	ns
Output Enable to Output Valid	t _{OE}		35		45		50		60	ns
Chip Select to Output in Low Z	t _{CLZ} ¹	3		3		3		3		ns
Output Enable to Output in Low Z	t _{OLZ} ¹	0		0		0		0		ns
Chip Disable to Output in High Z	t _{CHZ} ¹		25		25		35		35	ns
Output Disable to Output in High Z	t _{OHZ} ¹		25		25		35		35	ns

1. This parameter is guaranteed by design but not tested.

AC CHARACTERISTICS
(VCC = 5.0V, TA = -55°C To +125°C)

Parameter	Symbol	-70		-85		-100		-120		Units
		Min	Max	Min	Max	Min	Max	Min	Max	
Write Cycle										
Write Cycle Time	t _{WC}	70		85		100		120		ns
Chip Select to End of Write	t _{CW}	60		75		80		100		ns
Address Valid to End of Write	t _{AW}	60		75		80		100		ns
Data Valid to End of Write	t _{DW}	30		35		40		50		ns
Write Pulse Width	t _{WP}	50		55		70		80		ns
Address Setup Time	t _{AS}	0		0		0		0		ns
Address Hold Time	t _{AH}	5		5		5		5		ns
Output Active from End of Write	t _{OW} ¹	5		5		5		5		ns
Write Enable to Output in High Z	t _{WHZ} ¹		25		30		35		35	ns
Data Hold Time	t _{DH}	0		0		0		0		ns

1. This parameter is guaranteed by design but not tested.

AC TEST CIRCUIT



AC TEST CONDITIONS

Parameter	Typ	Unit
Input Pulse Levels	$V_{IL} = 0, V_{IH} = 3.0$	V
Input Rise and Fall	5	ns
Input and Output Reference Level	1.5	V
Output Timing Reference Level	1.5	V

Notes:
 V_Z is programmable from -2V to +7V.
 I_{OL} & I_{OH} programmable from 0 to 16mA.
 Tester Impedance $Z_0 = 75\Omega$.
 V_Z is typically the midpoint of V_{OH} and V_{OL} .
 I_{OL} & I_{OH} are adjusted to simulate a typical resistive load circuit.
 ATE tester includes jig capacitance.



TIMING WAVEFORM - READ CYCLE



WRITE CYCLE - \overline{WE} CONTROLLED



WRITE CYCLE - \overline{CS} CONTROLLED

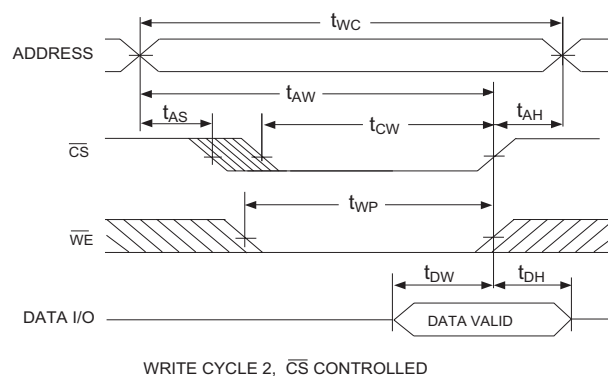



PACKAGE 101: 32 LEAD, CERAMIC SOJ



ALL LINEAR DIMENSIONS ARE MILLIMETERS AND PARENTHETICALLY IN INCHES

PACKAGE 206: 32 LEAD, CERAMIC FLAT PACK



ALL LINEAR DIMENSIONS ARE MILLIMETERS AND PARENTHETICALLY IN INCHES



PACKAGE 300: 32 PIN, CERAMIC DIP, SINGLE CAVITY SIDE BRAZED



ALL LINEAR DIMENSIONS ARE MILLIMETERS AND PARENTHETICALLY IN INCHES



**DATA RETENTION CHARACTERISTICS
(TA = -55°C TO +125°C)
LOW POWER VERSION ONLY**

Parameter	Symbol	Conditions			Units
			Min	Max	
Data Retention Supply Voltage	V _{DR}	$\overline{CS} \geq V_{CC} - 0.2V$	2.0	5.5	V
Data Retention Current	I _{CCDR3}	V _{CC} = 2V		750	μA

ORDERING INFORMATION

W M S 128K 8 X - XXX X X X

LEAD FINISH:

Blank = Gold plated leads
A = Solder clip leads

DEVICE GRADE:

M = Military Screened -55°C to +125°C
I = Industrial -40°C to +85°C
C = Commercial 0°C to +70°C

PACKAGE:

C = 32 Pin Ceramic .600" DIP (Package 300)
DE = 32 Lead Ceramic SOJ (Package 101) Evolutionary
DR = 32 Lead Ceramic SOJ (Package 101) Revolutionary
FE = 32 Lead Ceramic Flat Pack (Package 206)

ACCESS TIME (ns)

IMPROVEMENT MARK

L = Low Power for 2V Data Retention

ORGANIZATION, 128K x 8

SRAM

MONOLITHIC

WHITE ELECTRONIC DESIGNS CORP.



DEVICE TYPE	SPEED	PACKAGE	SMD NO.
128K x 8 SRAM Monolithic	120ns	32 lead SOJ Revol (DR)	5962-96691 01HUX
128K x 8 SRAM Monolithic	100ns	32 lead SOJ Revol (DR)	5962-96691 02HUX
128K x 8 SRAM Monolithic	85ns	32 lead SOJ Revol (DR)	5962-96691 03HUX
128K x 8 SRAM Monolithic	70ns	32 lead SOJ Revol (DR)	5962-96691 04HUX
128K x 8 SRAM Monolithic	120ns	32 lead SOJ Evol (DE)	5962-96691 01HTX
128K x 8 SRAM Monolithic	100ns	32 lead SOJ Evol (DE)	5962-96691 02HTX
128K x 8 SRAM Monolithic	85ns	32 lead SOJ Evol (DE)	5962-96691 03HTX
128K x 8 SRAM Monolithic	70ns	32 lead SOJ Evol (DE)	5962-96691 04HTX
128K x 8 SRAM Monolithic	120ns	32 pin DIP (C)	5962-96691 01HYX
128K x 8 SRAM Monolithic	100ns	32 pin DIP (C)	5962-96691 02HYX
128K x 8 SRAM Monolithic	85ns	32 pin DIP (C)	5962-96691 03HYX
128K x 8 SRAM Monolithic	70ns	32 pin DIP (C)	5962-96691 04HYX
128K x 8 SRAM Monolithic	120ns	32 pin Flatpack (FE)	5962-96691 01HNX
128K x 8 SRAM Monolithic	100ns	32 pin Flatpack (FE)	5962-96691 02HNX
128K x 8 SRAM Monolithic	85ns	32 pin Flatpack (FE)	5962-96691 03HNX
128K x 8 SRAM Monolithic	70ns	32 pin Flatpack (FE)	5962-96691 04HNX