



WM2616

12-bit Serial Input Voltage Output DAC

Production Data June 1999, Rev1.0

FEATURES

- 12-bit voltage output DAC
- Single supply from 2.7V to 5.5V
- DNL ± 0.5 LSB, INL ± 1.9 LSB
- Very low power consumption (3V supply):
 - 900 μ W, slow mode
 - 2.1mW, fast mode
- TMS320, (Q)SPI™, and Microwire™ compatible serial interface
- Programmable settling time of 4 μ s or 12 μ s typical
- High impedance reference input buffer

APPLICATIONS

- Battery powered test instruments
- Digital offset and gain adjustment
- Battery operated/remote industrial controls
- Machine and motion control devices
- Wireless telephone and communication systems
- Speech synthesis
- Arbitrary waveform generation

ORDERING INFORMATION

DEVICE	TEMP. RANGE	PACKAGE
WM2616CD	0° to 70°C	8-pin SOIC
WM2616ID	-40° to 85°C	8-pin SOIC

BLOCK DIAGRAM

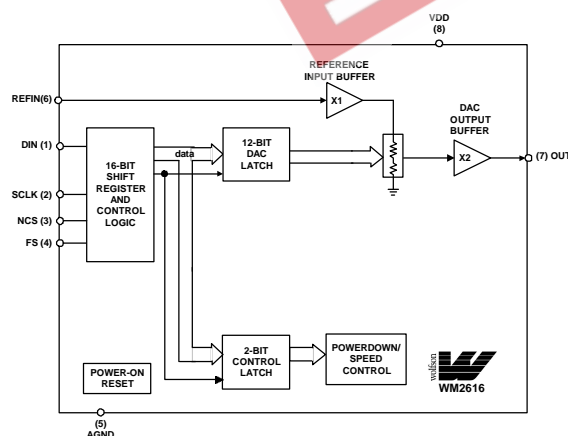

DESCRIPTION

The WM2616 is a 12-bit voltage output, resistor string digital-to-analogue converter that can be powered down under software control. Power down reduces current consumption to 10nA.

The device has been designed to interface efficiently to industry standard microprocessors and DSPs, including the TMS320 family. The WM2616 is programmed with a 16-bit serial word comprising 4 control bits and 12 data bits.

Excellent performance is delivered with a typical DNL of 0.5LSBs. The settling time of the DAC is programmable to allow the designer to optimize speed versus power dissipation. The output stage is buffered by a x2 gain rail-to-rail amplifier, which features a Class AB output stage.

The device is available in an 8-pin SOIC package. Commercial temperature (0° to 70°C) and Industrial temperature (-40° to 85°C) variants are supported.

TYPICAL PERFORMANCE

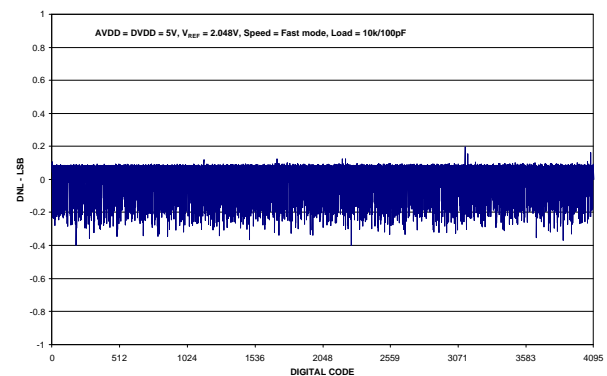

PIN CONFIGURATION

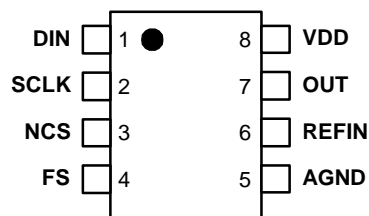

PIN DESCRIPTION

PIN NO	NAME	TYPE	DESCRIPTION
1	DIN	Digital input	Serial data input.
2	SCLK	Digital input	Serial clock input.
3	NCS	Digital input	Chip select. This pin is active low.
4	FS	Digital input	Frame synchronisation for serial input data.
5	AGND	Supply	Analogue ground.
6	REFIN	Analogue input	Voltage reference input.
7	OUT	Analogue output	DAC analogue output
8	VDD	Supply	Positive power supply.

ABSOLUTE MAXIMUM RATINGS

Absolute Maximum Ratings are stress ratings only. Permanent damage to the device may be caused by continuously operating at or beyond these limits. Device functional operating limits and guaranteed performance specifications are given under Electrical Characteristics at the test conditions specified.



ESD Sensitive Device. This device is manufactured on a CMOS process. It is therefore generically susceptible to damage from excessive static voltages. Proper ESD precautions must be taken during handling and storage of this device.

CONDITION	MIN	MAX
Supply voltage, VDD to AGND		7V
Digital input voltage	-0.3V	VDD + 0.3V
Reference input voltage	-0.3V	VDD + 0.3V
Operating temperature range, T _A	WM2616CD	0°C
	WM2616ID	70°C
Storage temperature	-40°C	85°C
Lead temperature 1.6mm (1/16 inch) soldering for 10 seconds	-65°C	150°C
		260°C

RECOMMENDED OPERATING CONDITIONS

PARAMETER	SYMBOL	TEST CONDITIONS	MIN	TYP	MAX	UNIT
Supply voltage	VDD		2.7		5.5	V
High-level digital input voltage	V _{IH}	VDD = 2.7V to 5.5V	2			V
Low-level digital input voltage	V _{IL}	VDD = 2.7V to 5.5V				V
Reference voltage to REFIN	V _{REF}	See Note			VDD - 1.5	V
Load resistance	R _L		2	10		kΩ
Load capacitance	C _L				100	pF
Serial clock rate	f _{SCLK}				20	MHz
Operating free-air temperature	T _A	WM2616CD	0		70	°C
		WM2616ID	-40		85	°C

Note: Reference input voltages greater than VDD/2 will cause saturation for large DAC codes.

ELECTRICAL CHARACTERISTICS

Test Conditions:

$R_L = 10k\Omega$, $C_L = 100pF$. $V_{DD} = 5V \pm 10\%$, $V_{REF} = 2.048V$ and $V_{DD} = 3V \pm 10\%$, $V_{REF} = 1.024V$ over recommended operating free-air temperature range (unless noted otherwise).

PARAMETER	SYMBOL	TEST CONDITIONS	MIN	TYP	MAX	UNIT
Static DAC Specifications						
Resolution			12			bits
Integral non-linearity	INL	See Note 1		± 1.9	± 4	LSB
Differential non-linearity	DNL	See Note 2		± 0.5	± 1	LSB
Zero code error	ZCE	See Note 3		2	± 10	mV
Gain error	GE	See Note 4		0.1	± 0.6	% FSR
D.c. power supply rejection ratio	d.c. PSRR	See Note 5		0.5		mV/V
Zero code error temperature coefficient		See Note 6		10		ppm/ $^{\circ}C$
Gain error temperature coefficient		See Note 6		10		ppm/ $^{\circ}C$
DAC Output Specifications						
Output voltage range			0		$V_{DD} - 0.1$	V
Output load regulation		2k Ω to 10k Ω load See Note 7		0.1	0.25	%
Power Supplies						
Active supply current	I_{DD}	No load, $V_{IH} = V_{DD}$, $V_{IL} = 0V$				
		$V_{DD} = 5V$, $V_{REF} = 2.048V$ Slow		0.4	0.6	mA
		$V_{DD} = 5V$, $V_{REF} = 2.048V$ Fast		0.9	1.35	mA
		$V_{DD} = 3V$, $V_{REF} = 1.024V$ Slow		0.3	0.45	mA
		$V_{DD} = 3V$, $V_{REF} = 1.024V$ Fast See Note 8		0.7	1.1	mA
Power down supply current		No load, all digital inputs 0V or VDD See Note 9		0.01	10	μA
Dynamic DAC Specifications						
Slew rate		DAC code 128 to 4095, 10%-90% Slow Fast See Note 10	0.5	0.9		$V/\mu s$
			2.5	3.6		$V/\mu s$
Settling time		DAC code 128 to 4095 Slow Fast See Note 11		12.0		μs
				4.0		μs
Glitch energy		Code 2047 to 2048		10		nV-s
Signal to noise ratio	SNR	$f_s = 400kpsps$, $f_{OUT} = 1kHz$, BW = 20kHz See Note 12	66	74		dB
Signal to noise and distortion ratio	SNRD	$f_s = 400kpsps$, $f_{OUT} = 1kHz$, BW = 20kHz See Note 12	54	66		dB
Total harmonic distortion	THD	$f_s = 400kpsps$, $f_{OUT} = 1kHz$, BW = 20kHz See Note 12		-68	-56	dB
Spurious free dynamic range	SPFDR	$f_s = 400kpsps$, $f_{OUT} = 1kHz$, BW = 20kHz See Note 12	56	70		dB

Test Conditions:

$R_L = 10k\Omega$, $C_L = 100pF$. $V_{DD} = 5V \pm 10\%$, $V_{REF} = 2.048V$ and $V_{DD} = 3V \pm 10\%$, $V_{REF} = 1.024V$ over recommended operating free-air temperature range (unless noted otherwise).

PARAMETER	SYMBOL	TEST CONDITIONS	MIN	TYP	MAX	UNIT
Reference						
Reference input resistance	R_{REFIN}			10		M Ω
Reference input capacitance	C_{REFIN}			5		pF
Reference feedthrough		$V_{REF} = 1V_{PP}$ at 1kHz + 1.024V dc, DAC code 0		-75		dB
Reference input bandwidth		$V_{REF} = 0.2V_{PP} + 1.024V$ dc DAC code 2048 Slow Fast		0.5 1.3		MHz MHz
Digital Inputs						
High level input current	I_{IH}	Input voltage = VDD			1	μA
Low level input current	I_{IL}	Input voltage = 0V			-1	μA
Input capacitance	C_I			3		pF

Notes:

- Integral non-linearity (INL)** is the maximum deviation of the output from the line between zero and full scale (excluding the effects of zero code and full scale errors).
- Differential non-linearity (DNL)** is the difference between the measured and ideal 1LSB amplitude change of any adjacent two codes. A guarantee of monotonicity means the output voltage changes in the same direction (or remains constant) as a change in digital input code.
- Zero code error** is the voltage output when the DAC input code is zero.
- Gain error** is the deviation from the ideal full scale output excluding the effects of zero code error.
- Power supply rejection ratio** is measured by varying VDD from 4.5V to 5.5V and measuring the proportion of this signal imposed on the zero code error and the gain error.
- Zero code error** and **Gain error** temperature coefficients are normalised to full scale voltage.
- Output load regulation** is the difference between the output voltage at full scale with a 10k Ω load and 2k Ω load. It is expressed as a percentage of the full scale output voltage with a 10k Ω load.
- I_{DD} is measured while continuously writing code 2048 to the DAC. For $V_{IH} < V_{DD} - 0.7V$ and $V_{IL} > 0.7V$ supply current will increase.
- Typical supply current** in power down mode is 10nA. Production test limits are wider for speed of test.
- Slew rate** results are for the lower value of the rising and falling edge slew rates
- Settling time** is the time taken for the signal to settle to within 0.5LSB of the final measured value for both rising and falling edges. Limits are ensured by design and characterisation, but are not production tested.
- SNR, SNRD, THD** and **SPFDR** are measured on a synthesised sinewave at frequency f_{OUT} generated with a sampling frequency f_s .

SERIAL INTERFACE

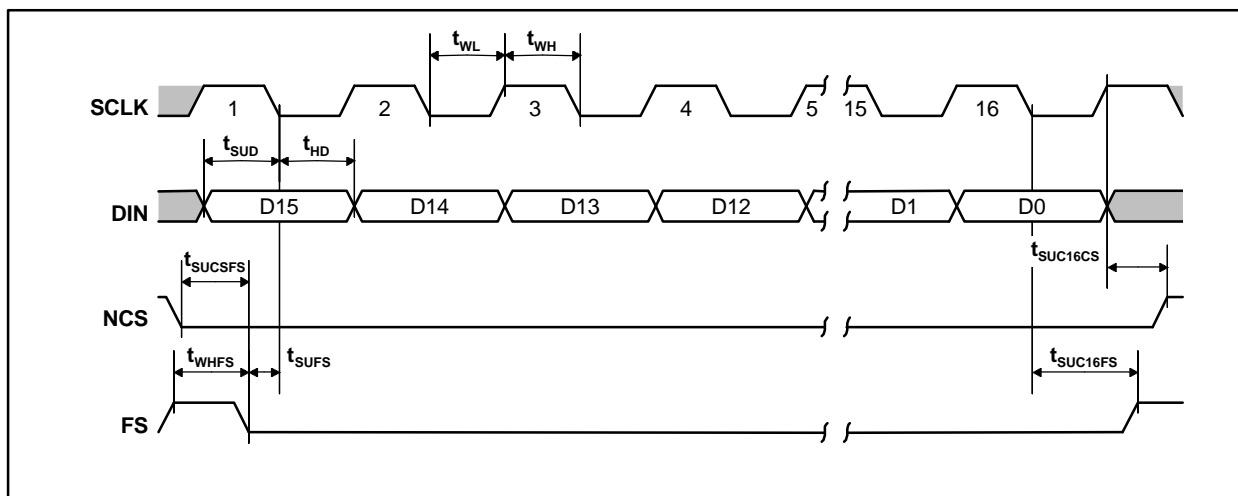

Figure 1 Timing Diagram

Test Conditions:

RL = 10kΩ, CL = 100pF. VDD = 5V ± 10%, VREF = 2.048V and VDD = 3V ± 10%, VREF = 1.024V over recommended operating free-air temperature range (unless noted otherwise).

SYMBOL	TEST CONDITIONS	MIN	TYP	MAX	UNIT
t _{SUCSFS}	Setup time NCS low before negative FS edge.	10			ns
t _{SUFs}	Setup time FS low before first negative SCLK edge.	8			ns
t _{SUC16FS}	Setup time, sixteenth negative SCLK edge after FS low on which D0 is sampled before rising edge of FS.	10			ns
t _{SUC16CS}	Setup time, sixteenth positive SCLK edge (first positive after D0 sampled) before NCS rising edge. If FS is used instead of the sixteenth positive edge to update the DAC, then the setup time is between the FS rising edge and the NCS rising edge.	10			ns
t _{WH}	Pulse duration, SCLK high.	25			ns
t _{WL}	Pulse duration, SCLK low.	25			ns
t _{SUD}	Setup time, data ready before SCLK falling edge.	8			ns
t _{HD}	Hold time, data held valid after SCLK falling edge.	5			ns
t _{WHFS}	Pulse duration, FS high.	20			ns

TYPICAL PERFORMANCE GRAPHS

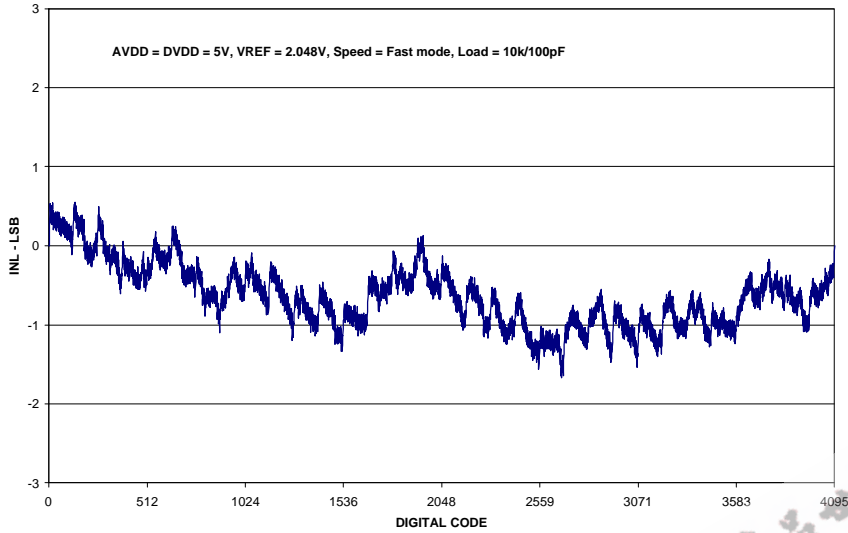

Figure 2 Integral Non-Linearity

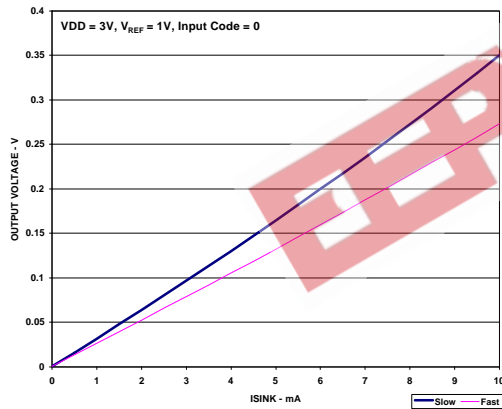

Figure 3 Sink Current VDD = 3V

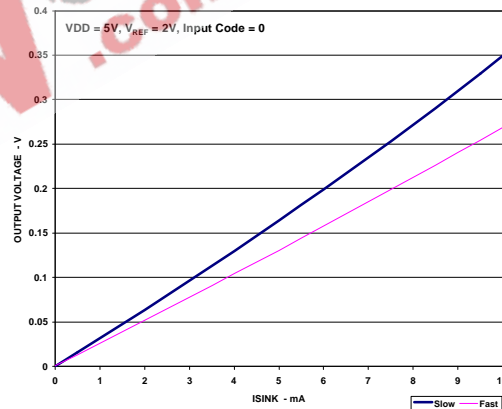

Figure 4 Sink Current VDD = 5V

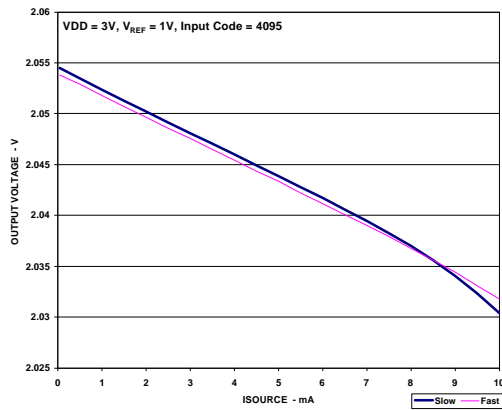

Figure 5 Source Current VDD = 3V

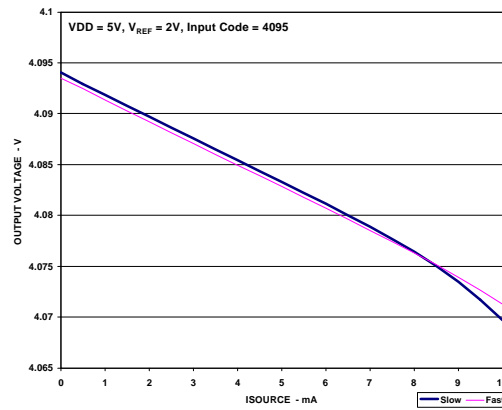

Figure 6 Source Current VDD = 5V

DEVICE DESCRIPTION

GENERAL FUNCTION

The device uses a resistor string network buffered with an op amp to convert 12-bit digital data to analogue voltage levels (see Block Diagram). The output voltage is determined by the reference input voltage and the input code according to the following relationship:

$$\text{Output voltage} = 2(V_{\text{REFIN}}) \frac{\text{CODE}}{4096}$$

INPUT			OUTPUT
1111	1111	1111	$2(V_{\text{REF}}) \frac{4095}{4096}$
	:		:
1000	0000	0001	$2(V_{\text{REF}}) \frac{2049}{4096}$
1000	0000	0000	$2(V_{\text{REF}}) \frac{2048}{4096} = V_{\text{REF}}$
0111	1111	1111	$2(V_{\text{REF}}) \frac{2047}{4096}$
	:		:
0000	0000	0001	$2(V_{\text{REF}}) \frac{1}{4096}$
0000	0000	0000	0V

Table 1 Binary Code Table (0V to $2V_{\text{REFIN}}$ Output), Gain = 2

POWER ON RESET

An internal power-on-reset circuit resets the DAC register to all 0s on power-up.

BUFFER AMPLIFIER

The output buffer has a near rail-to-rail output with short circuit protection and can reliably drive a 2k Ω load with a 100pF load capacitance.

EXTERNAL REFERENCE

The reference voltage input is buffered which makes the DAC input resistance independent of code. The REF_{IN} pin has an input resistance of 10M Ω and an input capacitance of typically 5pF. The reference voltage determines the DAC full-scale output.

SERIAL INTERFACE

Explanation of data transfer:

First, the device has to be enabled with NCS set to low. Then, a falling edge of FS starts shifting the data bit-per-bit (starting with the MSB) to the internal register on the falling edges of SCLK. After 16 bits have been transferred, the next rising edge on SCLK or FS causes the content of the shift register to be moved to the DAC latch which updates the voltage output to the new level.

The serial interface of the device can be used in two basic modes:

- four wire (with chip select)
- three wire (without chip select)

Using chip select (four wire mode), it is possible to have more than one device connected to the serial port of the data source (DSP or microcontroller). If there is no need to have more than one device on the serial bus, then NCS can be tied low.

SERIAL CLOCK AND UPDATE RATE

Figure 1 shows the device timing. The maximum serial rate is:

$$f_{\text{SCLKmax}} = \frac{1}{t_{\text{WCHmin}} + t_{\text{WCLmin}}} = 20\text{MHz}$$

The digital update rate is limited to an 800ns period, or 1.25MHz frequency. However, the DAC settling time to 12 bits limits the update rate for large input step transitions.

SOFTWARE CONFIGURATION OPTIONS

The 16 bits of data can be transferred with the sequence shown in Table 2. D11-D0 contains the 12-bit data word. D14-D13 hold the programmable options.

D15	D14	D13	D12	D11	D10	D9	D8	D7	D6	D5	D4	D3	D2	D1	D0
x	SPD	PWR	x	New DAC value (12 bits)											

Table 2 Register Map

PROGRAMMABLE SETTLING TIME

Settling time is a software selectable 12 μ s or 4 μ s typical, to within ± 0.5 LSB of final value. This is controlled by the value of D14. A ONE defines a settling time of 4 μ s, a ZERO defines a settling time of 12 μ s.

PROGRAMMABLE POWER DOWN

The power down function is controlled by D13. A ZERO configures the device as active, or fully powered up, a ONE configures the device into power down mode. When the power down function is released the device reverts to the DAC code set prior to power down.

EEPW.com.cn 电子产品世界

PACKAGE DIMENSIONS

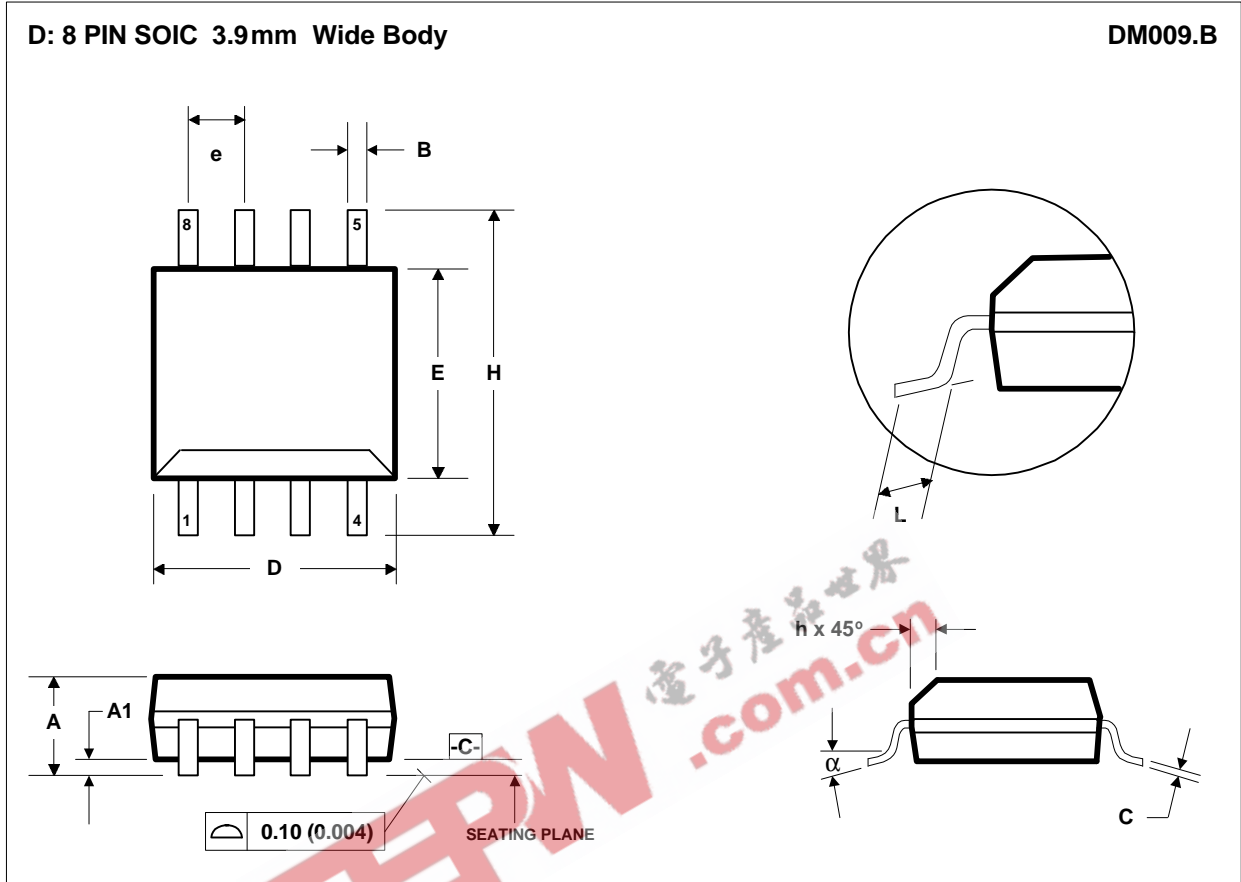

Symbols	Dimensions (mm)		Dimensions (Inches)	
	MIN	MAX	MIN	MAX
A	1.35	1.75	0.0532	0.0688
A ₁	0.10	0.25	0.0040	0.0098
B	0.33	0.51	0.0130	0.0200
C	0.19	0.25	0.0075	0.0098
D	4.80	5.00	0.1890	0.1968
e	1.27 BSC		0.050 BSC	
E	3.80	4.00	0.1497	0.1574
h	0.25	0.50	0.0099	0.0196
H	5.80	6.20	0.2284	0.2440
L	0.40	1.27	0.0160	0.0500
α	0°	8°	0°	8°
REF:	JEDEC.95, MS-012			

- NOTES:
 A. ALL LINEAR DIMENSIONS ARE IN MILLIMETERS (INCHES).
 B. THIS DRAWING IS SUBJECT TO CHANGE WITHOUT NOTICE.
 C. BODY DIMENSIONS DO NOT INCLUDE MOLD FLASH OR PROTRUSION, NOT TO EXCEED 0.25MM (0.010IN).
 D. MEETS JEDEC.95 MS-012, VARIATION = AA. REFER TO THIS SPECIFICATION FOR FURTHER DETAILS.