

# Energy Management Modular Power Quality Analyzer Type WM23-96



- Phases asymmetry control
- Optional RS 232 serial port
- Optional RS 422/485 serial port

## Product Description

µP-based three-phase modular power quality analyzer with built-in programming key-pad. Particularly recommended for

a detailed analysis of the electrical variables and of the power quality. Housing for panel mounting and IP65 (front) protection degree.

- Accuracy  $\pm 0.5$  F.S. (current/voltage)
- Three-phase modular power analyzer
- Backlighted LCD 4x3 1/2 DGT Display
- Front size: 96x96 mm
- Measurements of phase and system variables: W,  $W_{dmd}$ , var, VA,  $VA_{dmd}$ , PF,  $V_{L-N}$ ,  $V_{L-L}$ , A, An, Hz, THD-A, THD-V
- TRMS measurement of distorted waves (voltages/currents)
- Measurement of MAX values: W L1, W L2, W L3,  $W_{\Sigma}$ ,  $W_{dmd}$  (AL1-AL2-AL3 max on request)
- Measurement of MIN values: PF L1, PF L2, PF L3,  $PF_{\Sigma}$
- Harmonic analysis (FFT) up to the 16<sup>th</sup> harmonic (current and voltage)
- Instantaneous variables read-out: 4x3 1/2 digit
- Up to 2 optional relay or open collector outputs
- 1 optional analogue output
- MODBUS, JBUS Protocol
- Protection degree (front): IP 65
- Universal power supply: 18-60VAC/VDC, 90-260 VAC/VDC

## Ordering Key

**WM23-96AV53H XX XX XX XX X**

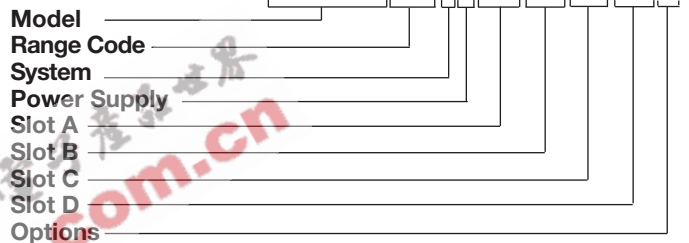

## Type selection

Range code	Slot A (signal retransmission)	Slot B (communication)	Slot C (redundant output or digital inputs)
<b>AV4:</b> 208VLL/5(6)AAC -20% ≤ Un ≤ +20%	<b>XX:</b> None	<b>XX:</b> None	<b>XX:</b> None
<b>AV5:</b> 400VLL/5(6)AAC -20% ≤ Un ≤ +15%	<b>A1:</b> Single analogue output, 20mADC	<b>S1:</b> Serial port, RS485 multidrop, bidirectional	<b>R1:</b> Single relay output (AC1-8AAC, 250VAC)
<b>AV6:</b> 100VLL/5(6)AAC -20% ≤ Un ≤ +15%	<b>A2:</b> Single analogue output, ±5mADC	<b>NOTE: max. digital output (alarms and/or pulses): 2, any exceeding output is redundant.</b>	<b>R2:</b> Dual relay output (AC1-8AAC, 250VAC)
<b>AV7:</b> 660VLL/5(6)AAC -30% ≤ Un ≤ +15%	<b>A3:</b> Single analogue output, ±10mADC		<b>O1:</b> Single open collector output (30V/100mADC)
50-60 Hz for all input modules. Module not removable.	<b>A4:</b> Single analogue output, ±20mADC	<b>NOTE: the second analogue output is intended as redundant type only.</b>	<b>O2:</b> Dual open collector output (30V/100mADC)
<b>System</b>	<b>B1:</b> Dual analogue output, 20mADC		<b>D1:</b> 3 digital inputs
<b>3:</b> Three-phase, unbalanced load, with or without neutral	<b>B2:</b> Dual analogue output, ±5mADC	<b>NOTE: with the A, B, C, D types power supply, only an open collector module or a single relay output module can be used. The instrument can be fully equipped only with L and H type power supply.</b>	<b>D2:</b> 3 digital inputs + aux output
<b>Power supply</b>	<b>B3:</b> Dual analogue output, ±10mADC		<b>Slot D (alarm output)</b>
<b>A:</b> 24 VAC -15 +10% 50-60Hz	<b>B4:</b> Dual analogue output, ±20mADC	<b>XX:</b> None	<b>R1:</b> Single relay output, (AC1-8AAC, 250VAC)
<b>B:</b> 48 VAC -15 +10% 50-60Hz	<b>V1:</b> Single analogue output, 10VDC	<b>R2:</b> Dual relay output, (AC1-8AAC, 250VAC)	<b>O1:</b> Single open collector output (30V/100mADC)
<b>C:</b> 115VAC -15 +10% 50-60Hz	<b>V2:</b> Single analogue output, ±1VDC	<b>O2:</b> Dual open collector output (30V/100mADC)	<b>Options</b>
<b>D:</b> 230 VAC -15 +10% 50-60Hz	<b>V3:</b> Single analogue output, ±5VDC	<b>X:</b> None	<b>S:</b> RS232 serial port displaying and recording of AL1-AL2-AL3 max instead of WL1-WL2-WL3 max.
<b>L:</b> 18 to 60VAC/VDC	<b>V4:</b> Single analogue output, ±10VDC	<b>A:</b> Options: S+A above.	
<b>H:</b> 90 to 260VAC/VDC	<b>W1:</b> Dual analogue output, 10VDC		
	<b>W2:</b> Dual analogue output, ±1VDC		
	<b>W3:</b> Dual analogue output, ±5VDC		
	<b>W4:</b> Dual analogue output, ±10VDC		

## Input Specifications

<b>Number of analogue inputs</b>		Active power (@ 25°C ± 5°C, R.H. ≤ 60%)	±(1% Pn +2DGT)
Current	3	Reactive Power (@ 25°C ± 5°C, R.H. ≤ 60%)	±(2% Pn +2DGT)
Voltage	4	Apparent power (@ 25°C ± 5°C, R.H. ≤ 60%)	±(1% Pn +2DGT)
<b>Digital Inputs</b>	On request	Harmonic distortion (@ 25°C ± 5°C, R.H. ≤ 60%)	±3% F.S. (up to 16 <sup>th</sup> harmonic) (F.S.: 100%)
AQ1038	Number of inputs: 3 (voltage free)	<b>Additional errors</b>	
Use	Synchronization of the W-VA dmd measurements	Humidity	≤0.3% F.S. from 60% to 90% H.R.
	Input 1: lock of programming	<b>Temperature drift</b>	≤ 200ppm/°C
	Inputs 2 and 3: W-VA dmd measurements synchronization	<b>Display</b>	Back-lighted LCD 4x3 <sup>1</sup> / <sub>2</sub> digit 70 x 38mm
Reading voltage	24VDC/1mA	<b>Display refresh time</b>	700ms
AQ1042	Number of inputs: 3 + inputs power supply	<b>Measurements</b>	Current, voltage, power, power factor, frequency, harmonic distortion. TRMS measurement of a distorted wave.
Input frequency	Max 20Hz, dutycycle 50%	Coupling type	Direct
Output voltage	16V<+Aux<24VDC	<b>Input impedance</b>	
Output current	Max 15mA	208VLL 5(6)AAC (AV4):	>200 kΩ
Open contact resistance		400VLL 5(6)AAC (AV5):	>900 kΩ
Insulation	Min 100kΩ 4000VRMS	100VLL 5(6)AAC (AV6):	>200 kΩ
		660VLL 5(6)AAC (AV7):	>900 kΩ
<b>Accuracy</b> (display, RS232, RS485)	In=5A; Pn= In* Un Un: F.S. range AV4-5-6-7		
Current	±(0.5% In +2DGT)		
Phase-neutral voltage	±(0.5% Un +2DGT)		
Phase-phase voltage	±(1% Un +2DGT)		
Frequency	±0.1Hz		

## Output Specifications

<b>Analogue Outputs</b>	(on request)	Insulation	By means of optocouplers, 4000 V <sub>RMS</sub> output to measuring input
Number of outputs	Up to 1 (+1 redundant)		4000 V <sub>RMS</sub> output to supply input
Accuracy	±0.2% f.s. (@ 25°C ± 5°C, R.H. ≤ 60%)	<b>RS422/RS485</b>	(on request)
Range	0 to 20 mADC, 0 to ±20 mADC 0 to ±10 mADC, 0 to ±5 mADC 0 to 10 VDC, 0 to ±10 VDC 0 to ±5 VDC 0 to ±1 VDC	Connections	Multidrop bidirectional (static and dynamic variables) 2 or 4 wires, max. distance 1200m, termination directly on the instrument
Scaling factor:	Programmable within the whole range of retransmission; it allows the retransmission management of all values from: 0 and 20 mADC,	Addresses	255, selectable by key-pad
Variables	See relevant list	Protocol	MODBUS/JBUS (RTU)
Response time	≤ 900 ms typical (filter excluded, FFT excluded)	Data (bidirectional)	System and phase variables: see table "display pages"
Ripple	≤ 1%	Dynamic (reading only)	All the configuration parameters, activation of the static output.
Total temperature drift (put)	acc. to IEC 60688-1, EN 60688-1	Static (writing only)	1 start bit, 8 data bit, no parity, 1 stop bit
Load:	≤ 500 ppm/°C (input+output)	Data format	9600 bauds
20 mADC	≤ 600 Ω	Baud-rate	By means of optocouplers, 4000 V <sub>RMS</sub> output to measuring input
±20 mADC	≤ 550 Ω	Insulation	4000 V <sub>RMS</sub> output to supply input
±10 mADC	≤ 1100 Ω		
± 5 mADC	≤ 2200 Ω	<b>RS232</b>	(on request)
10 VDC	≥ 10 kΩ		bidirectional (static and dynamic variables)
±10 VDC	≥ 10 kΩ	Connections	3 wires, max. distance 15m,
± 5 VDC	≥ 10 kΩ	Data format	1 start bit, 8 data bit
± 1 VDC	≥ 10 kΩ		

## Output Specifications (cont.)

Baud-rate Protocol other data	no parity, 1 stop bit 9600 bauds MODBUS/JBUS (RTU) as per RS422/485	Output type	Relay, SPDT type AC 1-8A @ 250VAC DC 12-5A @ 24VDC AC 15-2.5A @ 250VAC DC 13-2.5A @ 24VDC
<b>Digital outputs</b>	(on request) To be used as alarms or remote control.	Min. response time	≤ 150 ms, filter excluded, FFT excluded, setpoint on-time delay: "0 s"
<b>Alarm outputs</b> Number of outputs Alarm type Variables to be controlled  Set-point adjustment  Hysteresis  On-time delay Relay status	(on request) up to 2, independent Up alarm, down alarm see the "List of the variables that can be connected..." from 0 to 100% of the electrical scale from 0 to 100% of the electrical scale 0 to 255s Selectable, normally de-energized and normally energized	Insulation          Note	By means of optocouplers, 4000 V <sub>RMS</sub> output to measuring input, 4000 V <sub>RMS</sub> output to supply input. The outputs can be either relay type or open collector type (V <sub>ON</sub> 1.2VDC/Max. 100mA, V <sub>OFF</sub> 30VDC Max.). Insulation like relay outputs.

## Software Functions

<b>Password</b>  1st level 2nd level	Numeric code of max 4 digits; 2 protection levels of the programming data Password "0", no protection Password from 1 to 1000, all data are protected.	Page 5: PF L1(min), PF L2 (min), PF L3 (min) Page 6: W L1, W L2, W L3 Page 7: W L1 (max), W L2 (max), W L3 (max)
<b>Transformer ratio</b>	CT from 1 to 5000 VT from 1.0 to 1999, where CT x VT ≤ 10000	Page 7: "A" option: AL1 (max) AL2 (max) AL3 (max)
<b>Power demand (dmd)</b> Integration time	Programmable from 1 to 30 min	Page 8: var L1, var L2, var L3 Page 9: VA L1, VA L2, VA L3 Page 10: AL1 (alarm 1) Page 11: AL2 (alarm 2) Page 12: WΣ, PFΣ, varΣ, Hz Page 13: WΣ, PFΣ, VAΣ, Hz Page 14: WΣ (max), PFΣ (min) Page 15: W dmd, VA dmd, r.t. Page 16: W dmd (max), VA dmd (max)
<b>Filter</b> Filter operating range  Filtering coefficient Filter action	From 0 to 100% of the input electrical scale 1 to 16 Measurements, alarms, serial port (fundamental variables: V, A, W and their derived ones).	Page 17: THD VL1, THD VL2, THD VL3 Page 17: THD AL1, THD AL2, THD AL3
<b>Page Variables</b> Three-phase system with neutral	Up to 4 by page Page 1: V L1, V L2, V L3, V LNΣ Page 2: V L12, V L13, V L31, VΣ Page 3: A L1, A L2, AL3, An Page 4: PF L1, PF L2, PF L3, PFΣ	

## Supply Specifications

<b>AC voltage</b>	90 to 260 VDC/VAC 18 to 60VDC/VAC 24 VAC -15+10% 50-60Hz 48 VAC -15+10% 50-60Hz	<b>Power consumption</b>	115VAC -15+10% 50-60Hz 230 VAC -15+10% 50-60Hz ≤ 30VA/12W (90 to 260V) ≤ 20VA/12W (18 to 60V)
-------------------	--	--------------------------	--



## General Specifications

<b>Operating temperature</b>	0 to +50°C (32 to 122°F) (R.H. < 90% non condensing)	<b>Immunity</b>	light industry environment EN 61000-6-2 (class A) industrial environment
<b>Storage temperature</b>	-10 to +60°C (14 to 140°F) (R.H. < 90% non condensing)	<b>Other standards</b>	Safety Product
<b>Installation category</b>	Cat. III (IEC 60664)	<b>Approvals</b>	IEC 61010-1, EN 61010-1 IEC 60688-1, EN 60688-1
<b>Pollution degree</b>	2	<b>Connections 5(6)A</b>	CE, UL, CSA
<b>Key-pad lock</b>	by means of a rotary switch placed behind the display or by means of a contact (in case of presence of the digital inputs module)	<b>Housing</b>	Dimensions Material
<b>Insulation</b>	4000 V <sub>RMS</sub> between all inputs/outputs to ground	<b>Protection degree</b>	96x96x140 mm ABS, NORYL, PC (front) self-extinguishing: UL 94 V-0
<b>Dielectric strength</b>	4000 V <sub>RMS</sub> for 1 minute	<b>Weight</b>	Front: IP65, NEMA4x, NEMA12 Connections: IP20 Approx. 400 g (packing incl.)
<b>EMC</b>			
Emissions	EN 61000-6-3 (class A) residential, commercial and		

## Function Description

### Input/analogue output scaling capability

Working of the analogue output (Y) versus the input variable (X) - (input/output scaling capability)

**Figure A**

The sign of measured quantity and output quantity remains the same. The output quantity is proportional to the measured quantity.

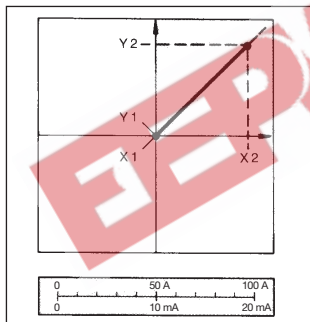

**Figure D**

The sign of measured quantity and output quantity remains the same. With the measured quantity being zero, the output quantity has the value  $Y_1 = 0.2$  (live zero output).

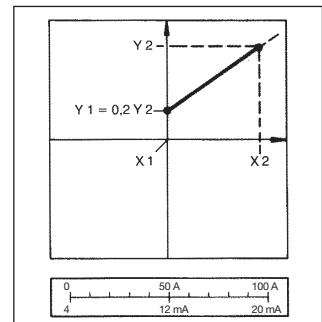

**Figure B**

The sign of measured quantity and output quantity changes simultaneously. The output quantity is proportional to the measured quantity.

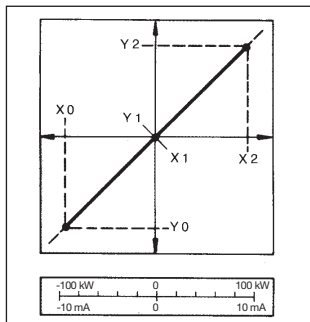

**Figure E**

The sign of the measured quantity changes but that of the output quantity remains the same. The output quantity steadily increases from the value  $X_1$  to the value  $X_2$  of the measured quantity.

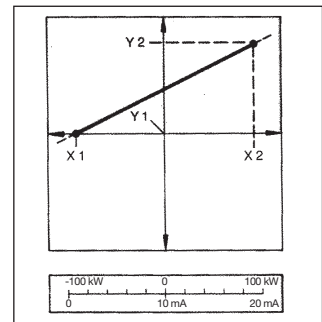

**Figure C**

The sign of measured quantity and output quantity remains the same. From  $X_0$  to  $X_1$ , the output variable is 0. The range  $X_1...X_2$  is delineated on the entire output range.

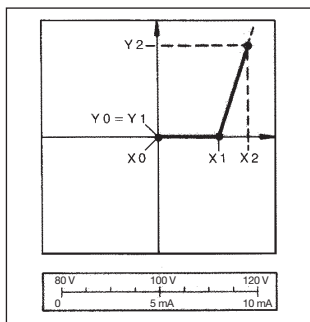

**Figure F**

The sign of the measured quantity remains the same, that of the output quantity changes as the measured quantity leaves range  $X_0...X_1$  and passes to range  $X_1...X_2$ .

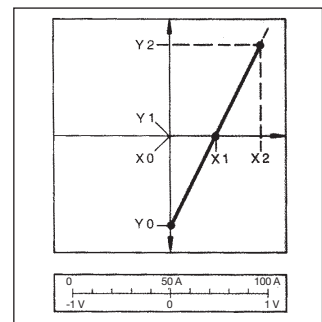

## Mode of operation

### Waveform of the signals that can be measured

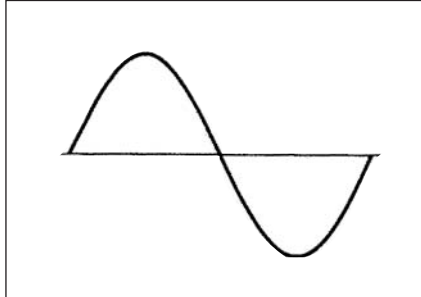

**Figure G**  
**Sinewave, undistorted**  
 Fundamental content 100%  
 Harmonic content 0%  
 $A_{rms} = 1.1107 | A |$

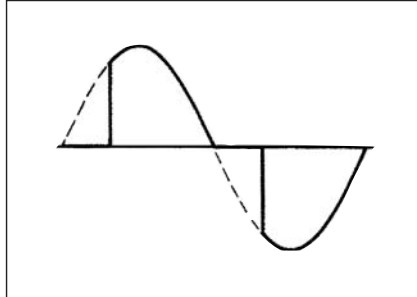

**Figure H**  
**Sinewave, indented**  
 Fundamental content 10...100%  
 Harmonic content 0...90%  
 Frequency spectrum: 3rd to 16th harmonic

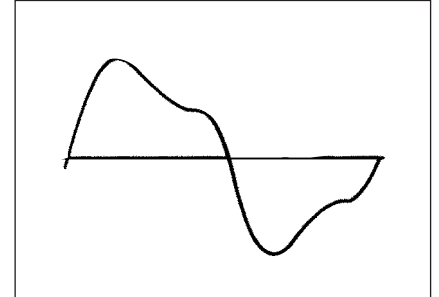

**Figure I**  
**Sinewave, distorted**  
 Fundamental content 70...90%  
 Harmonic content 10...30%  
 Frequency spectrum: 3rd to 16th harmonic

## Harmonic Analysis

<b>Analysis principle</b>	FFT	<b>Display pages</b>	THD %
<b>Harmonic measurement</b>		<b>Others</b>	The harmonic distortion can be measured in both 3-wire or 4-wire systems.
Current	Up to 16th harmonic		
Voltage	Up to 16th harmonic		
<b>Type of harmonics</b>	THD (V L1) THD (V L2) THD (V L3) THD (A L1) THD (A L2) THD (A L3)		

## Display pages

Variables that can be displayed in case of a three-phase system, 4-wire connection.

No	1st variable	2nd variable	3rd variable	4th variable	Notes
1	V L1	V L2	V L3	V LN Σ	Σ = system
2	V L1-2	V L2-3	V L3-1	V Σ	Σ = system
3	A L1	A L2	A L3	A n	A n= neutral current
4	PF L1	PF L2	PF L3	PF Σ	Σ = system
5	PF L1 (min)	PF L2 (min)	PF L3 (min)		
6	W L1	W L2	W L3		
7	W L1 (max)	W L2 (max)	W L3 (max)		With "A" option: AL1-AL2-AL3 max
8	var L1	var L2	var L3		
9	VA L1	VA L2	VA L3		
10	AL 1				variable connected to alarm 1
11	AL 2				variable connected to alarm 2
12	W Σ	PF Σ	var Σ	Hz	Σ = system
13	W Σ	PF Σ	VA Σ	Hz	Σ = system
14	W Σ (max)	PF Σ (min)			Σ = system
15	W dmd	VA dmd	r.t.		r.t.= symbol of communication Rx/Tx on the serial port
16	W dmd (max)	VA dmd (max)			
17	THD V L1	THD V L2	THD V L3		total harmonic distortion
18	THD A L1	THD A L2	THD A L3		total harmonic distortion

## Used Calculation Formula

### Phase Variables

Instantaneous effective voltage      Instantaneous effective current

$$V_{IN} = \sqrt{\frac{1}{n} \cdot \sum_1^n (V_{IN})_i^2}$$

$$A_1 = \sqrt{\frac{1}{n} \cdot \sum_1^n (A_1)_i^2}$$

Instantaneous active power

Instantaneous apparent power

$$VA_1 = V_{IN} \cdot A_1$$

$$W_1 = \frac{1}{n} \cdot \sum_1^n (V_{IN})_i \cdot (A_1)_i$$

Instantaneous reactive power

Instantaneous power factor

$$VAR_1 = \sqrt{(VA_1)^2 - (W_1)^2}$$

$$\cos\phi_1 = \frac{W_1}{VA_1}$$

### System variables

Three-phase active power      Equivalent three-phase voltage

$$W_\Sigma = W_1 + W_2 + W_3$$

$$V_\Sigma = \frac{V_{12} + V_{23} + V_{31}}{3}$$

Three-phase apparent power

Three-phase reactive power

$$VA_\Sigma = \sqrt{W_\Sigma^2 + VAR_\Sigma^2}$$

$$VAR_\Sigma = (VAR_1 + VAR_2 + VAR_3)$$

Three-phase power factor

Neutral current

$$\cos\phi_\Sigma = \frac{W_\Sigma}{VA_\Sigma}$$

$$An = \overline{A}_{L1} + \overline{A}_{L2} + \overline{A}_{L3}$$

Total harmonic distortion

Where:

$$THD_i = \frac{\sqrt{\sum_{n=2}^n T_{i,n}^2}}{T_{i,1}}$$

i = considered phase (L1, L2 or L3)

T = considered variable (V or A)

n = harmonic order

## List of the variables that can be connected to:

- Alarm outputs
- Analogue outputs

N°	Variable	3-phase + neutral	3-phase no neutral	Note
1	$V_{L-N\Sigma}$	x	x	$\Sigma$ = system
2	$V_{L-L\Sigma}$	x	x	$\Sigma$ = system
3	$W\Sigma$	x	x	$\Sigma$ = system
4	$var\Sigma$	x	x	$\Sigma$ = system
5	$VA\Sigma$	x	x	$\Sigma$ = system
6	$PF\Sigma$	x	x	$\Sigma$ = system
7	THD V (1)	x	x	if FFT is activated
8	THD A (1)	x	x	if FFT is activated
9	A n	x	x	
10	VA dmd	x	x	
11	W dmd	x	x	
12	ASY	x	x	asymmetry

(1) The highest value among the three phases

(2) The RS232 communication port works as alternative of the RS485 module.

## The possible module combinations

Basic unit	Slot A	Slot B	Slot C	Slot D
Single analogue output	●			
Dual analogue output	●			
RS485 port		●		
Single relay output			●	
Single open collector output			●	
Dual relay output			●	●
Dual open collector output			●	●
3 digital inputs			●	
3 digital inputs + AUX			●	
Basic unit	Slot E			
RS232 port			●	

## The available modules

Type	N. of channels	Ordering Code
WM23-96 400V L-L 5A (base)		AH2300
WM23-96 208V L-L 5A (base)		AH2301
WM23-96 100V L-L 5A (base)		AH2302
WM23-96 660V L-L 5A (base)		AH2303
WM23-96 400V L-L 5A (base)	"A" opt.	AH2300A
WM23-96 208V L-L 5A (base)	"A" opt.	AH2301A
WM23-96 100V L-L 5A (base)	"A" opt.	AH2302A
WM23-96 660V L-L 5A (base)	"A" opt.	AH2303A
24VAC power supply		AP1025
48VAC power supply		AP1024
115VAC power supply		AP1023
230VAC power supply		AP1022
18-60VAC/DC power supply		AP1021
90-260VAC/DC power supply		AP1020
20mADC analogue output	1	AO1050
10VDC analogue output	1	AO1051
±5mADC analogue output	1	AO1052
±10mADC analogue output	1	AO1053
±20mADC analogue output	1	AO1054
±1VDC analogue output	1	AO1055
±5VDC analogue output	1	AO1056
±10VDC analogue output	1	AO1057
20mADC analogue output	2	AO1026
10VDC analogue output	2	AO1027
±5mADC analogue output	2	AO1028
±10mADC analogue output	2	AO1029
±20mADC analogue output	2	AO1030
±1VDC analogue output	2	AO1031
±5VDC analogue output	2	AO1032
±10VDC analogue output	2	AO1033
Relay output	1	AO1058
Relay output	2	AO1035
Open collector output	1	AO1059
Open collector output	2	AO1036
Digital inputs	3	AQ1038
Digital inputs + AUX	3	AQ1042
RS485 serial port (2)	1	AR1034
RS232 serial port (2)	1	AR1039

# Wiring Diagrams

## Single phase

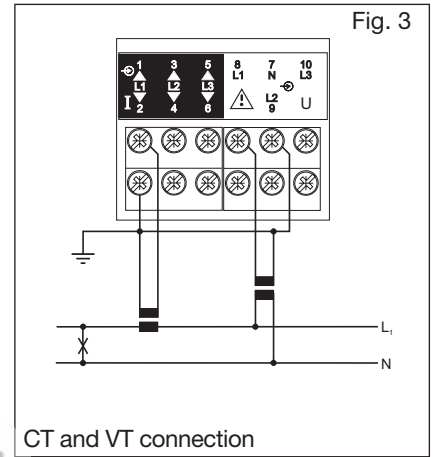
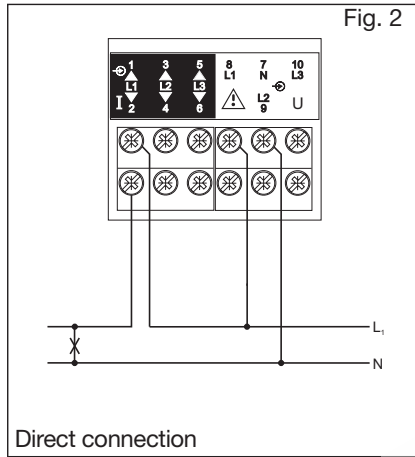
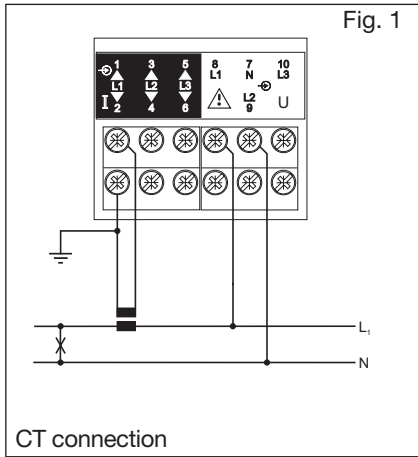

## Three-phase - Unbalanced load

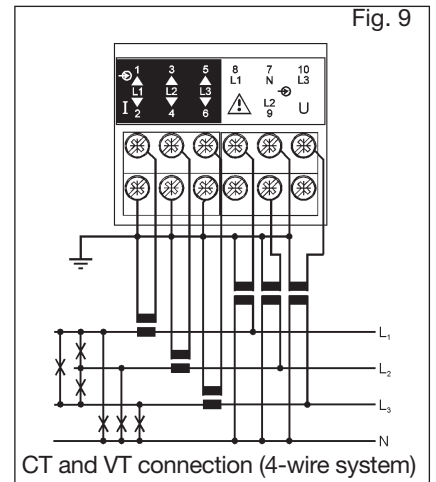
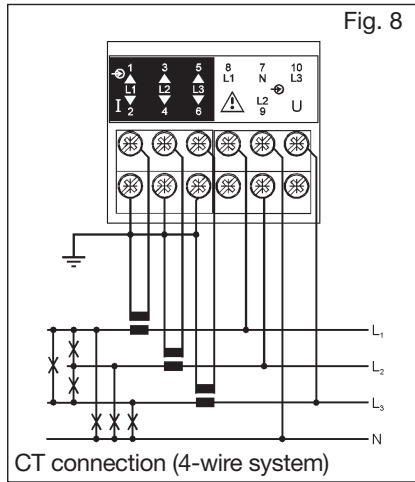
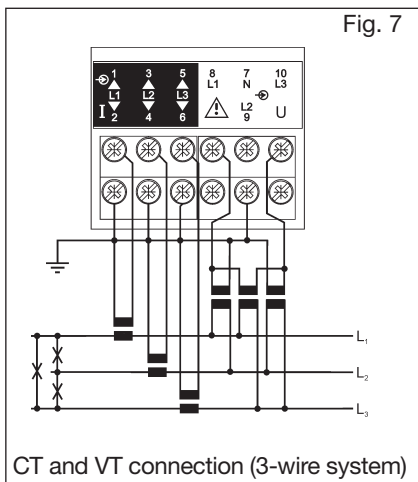
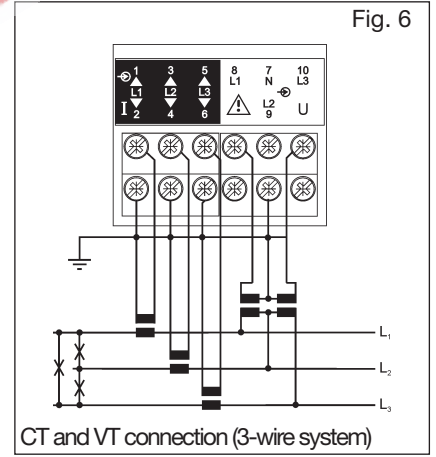
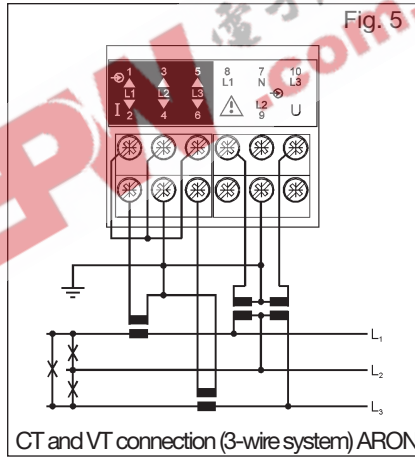
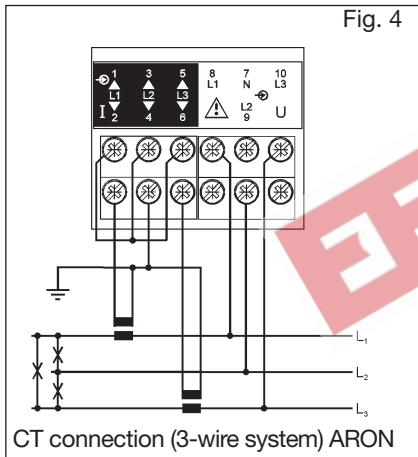



## Wiring diagrams (optional modules)

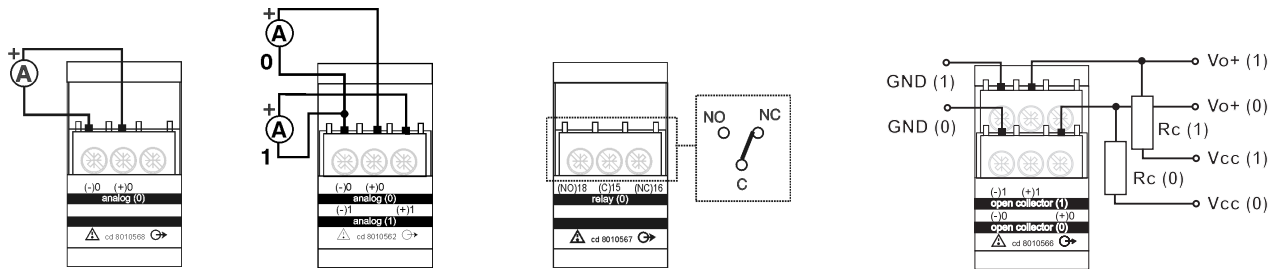

1 analogue output (mA)

2 analogue outputs (mA)

1 relay outputs

Open collector output connection. This wiring diagram is valid also for the open collector module with one output. The load resistances (RC) must be designed so that the close contact current is lower than 100mA; the VDC voltage must be lower than or equal to 30VDC.

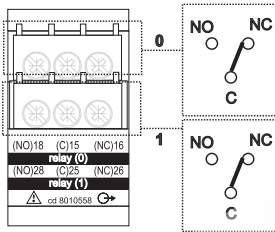
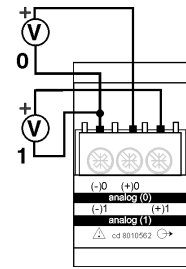
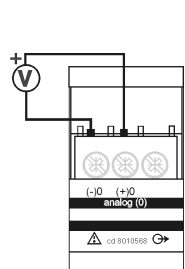

1 analogue output (V)

2 analogue outputs (V)

2 relay outputs

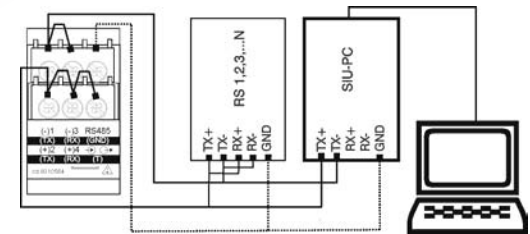
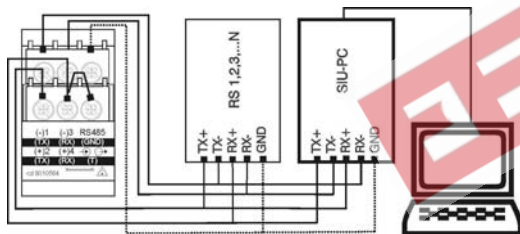

4-wire connection of RS485 serial port

2-wire connection of RS485 serial port

## Wiring diagrams: digital input modules

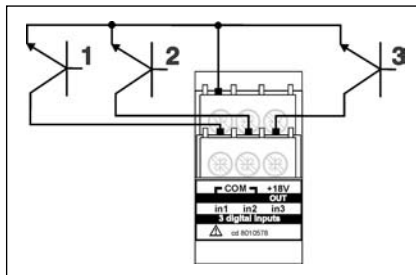

Connection by means of NPN transistors. Digital input module: AQ1042.

Connection by means of PNP transistors. Digital input module: AQ1042.

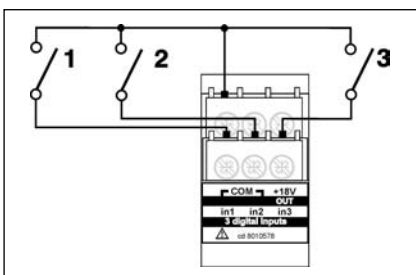
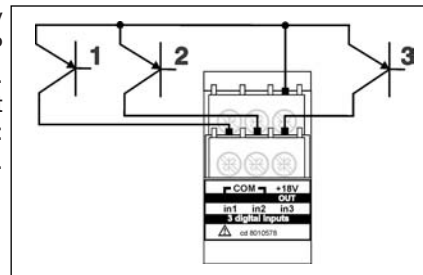

Connection by means of contacts. Digital input module: AQ1042.

Connection by means of contacts. Digital input module: AQ1038.

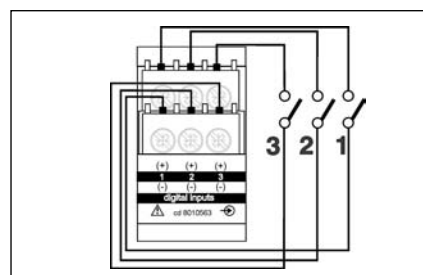



## Front Panel Description

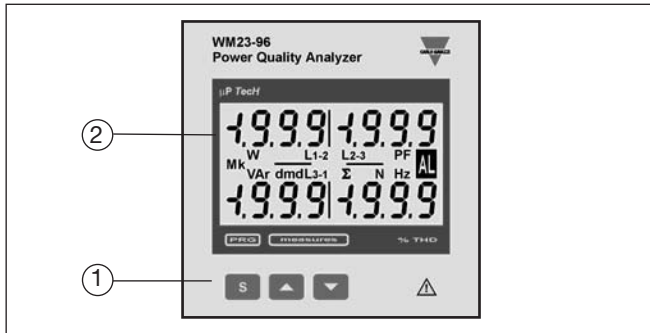

### 1. Key-pad

The programming of configuration parameters and the display are easily controlled by means of the 3 push buttons:

- "S" to enter into the programming phase and to confirm the password

▲ and ▼

- for value programming
- for function selections
- for page scrolling

### 2. Display

- Instantaneous measurements:
- 4x3 1/2 digit (maximum read-out 1999)

Alphanumeric indications by means of LCD display for:

- Displaying the configuration parameters
- Displaying all the measured variables.

### 3. Programming lock

It's possible to lock the programming key-pad by means of a rotary switch located behind the instrument into the power supply slot. Turn counterclockwise the switch to lock the programming key-pad.

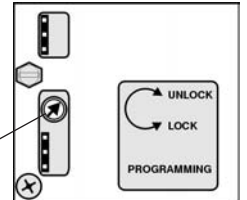

## Dimensions

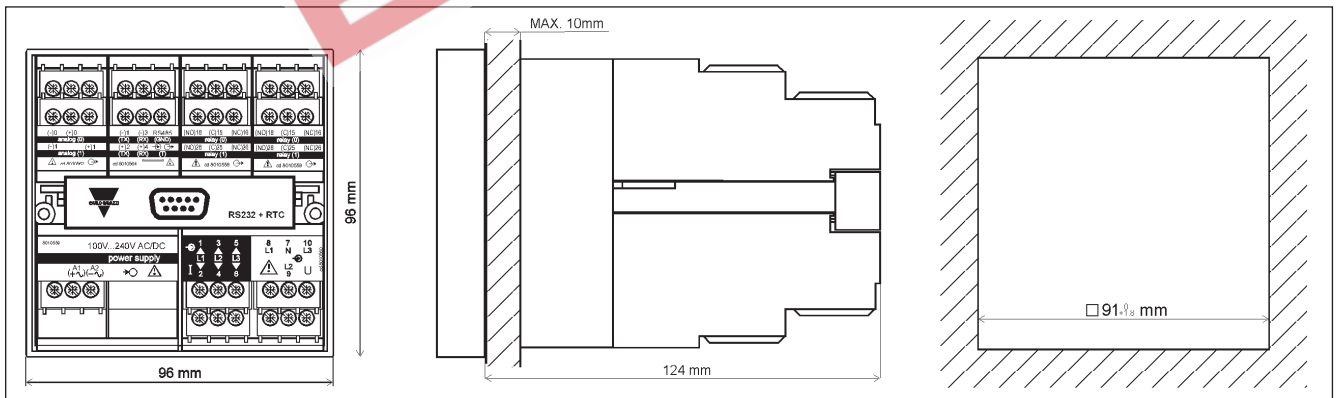



## Terminal boards

### Single analogue output modules

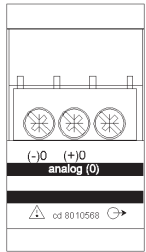

- AO1050** (20mADC)
- AO1051** (10VDC)
- AO1052** ( $\pm 5$ mADC)
- AO1053** ( $\pm 10$ mADC)
- AO1054** ( $\pm 20$ mADC)
- AO1055** ( $\pm 1$ VDC)
- AO1056** ( $\pm 5$ VDC)
- AO1057** ( $\pm 10$ VDC)

### Dual analogue output modules

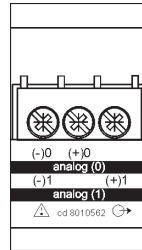

- AO1026** (20mADC)
- AO1027** (10VDC)
- AO1028** ( $\pm 5$ mADC)
- AO1029** ( $\pm 10$ mADC)
- AO1030** ( $\pm 20$ mADC)
- AO1031** ( $\pm 1$ VDC)
- AO1032** ( $\pm 5$ VDC)
- AO1033** ( $\pm 10$ VDC)

### Digital output modules

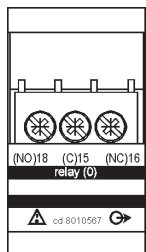

**AO1058**  
Single relay output

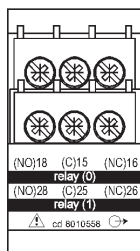

**AO1035**  
Dual relay output

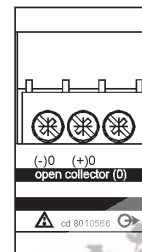

**AO1059**  
Single open collector output

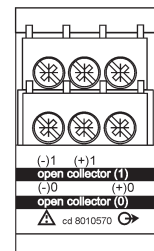

**AO1036**  
Dual open collector output

### Other input/output modules

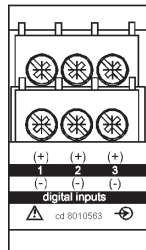

**AQ1038**  
3 digital inputs

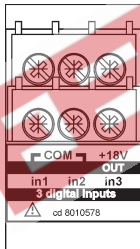

**AQ1042**  
3 digital inputs + aux

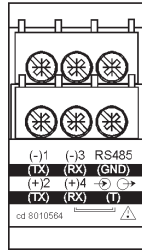

**AR1034**  
RS422/485 communication port



**AR1039**  
RS232 communication port

### Power supply modules

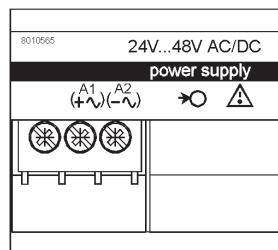

- AP1021** 18-60 VAC/DC power supply
- AP1020** 90-260 VAC/DC power supply
- AP1025** 24VAC power supply
- AP1024** 48VAC power supply
- AP1023** 115VCA power supply
- AP1022** 230VCA power supply