



WJA1015

+5V Active-Bias InGaP HBT Gain Block

Product Features

- 50 – 4000 MHz
- 14 dB Gain
- +19.5 dBm P1dB
- +35.5 dBm OIP3
- +5V Single Voltage Supply
- Internal Active Bias Supply
- Internally matched to 50 Ω
- Lead-free / RoHS-compliant / Green SOT-89 package

Applications

- GSM, PCS, CDMA, WCDMA
- Repeaters, BTS Transceivers
- UHF
- General Purpose

Product Description

The WJA1015 is a high performance amplifier that offers high linearity in a low-cost surface-mount package. At 900 MHz, the WJA1015 typically provides 14 dB gain, +35.5 dBm OIP3, and +19.5 dBm P1dB. The device is housed in a lead-free/green/RoHS-compliant SOT-89 industry-standard SMT package using a NiPdAu plating to eliminate the possibility of tin whiskering.

The WJA1015 consists of Darlington pair amplifiers using a high reliability InGaP/GaAs HBT process technology. The MMIC amplifier is internally matched to 50Ω and only requires DC-blocking capacitors and an inductive RF choke for operation. An internal active bias is designed to enable stable performance over temperature. It also eliminates the need for a dropping bias resistor and allows the device to be biased directly from a +5V supply voltage.

The amplifier is targeted for high performance RF applications in existing and next generation wireless technologies. In addition, the WJA1015 will work for various other applications within the 50 to 4000 MHz frequency range.

Functional Diagram

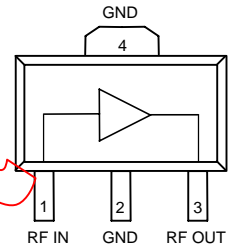

Function	Pin No.
Input	1
Output/Bias	3
Ground	2, 4

Specifications

Parameter	Units	Min	Typ	Max
Operational Bandwidth	MHz	50		4000
Test Frequency	MHz		900	
Gain	dB		14.1	
Input Return Loss	dB		11	
Output Return Loss	dB		11	
Output P1dB	dBm		+19.4	
Output IP3 ⁽²⁾	dBm		+35.5	
Noise Figure	dB		4.5	
Device Voltage	V		5	
Device Current	mA		67	

1. Test conditions: 25 °C, Supply Voltage = +5 V, 50 Ω System.
2. 3OIP measured with two tones at an output power of 0 dBm/tone separated by 1 MHz. The suppression on the largest IM3 product is used to calculate the 3OIP using a 2:1 rule.

Typical Performance

Parameter	Units	Typical			
Frequency	MHz	500	900	1900	2140
S21	dB	14.4	14.1	13.2	13
S11	dB	-12	-11	-7.7	-7.2
S22	dB	-14	-11	-7	-6.7
Output P1dB	dBm	+19.5	+19.4	+17.4	+16.6
Output IP3 ⁽²⁾	dBm	+39.4	+35.5	+26.8	+26.3
Noise Figure	dB	4.4	4.5	4.9	5.0

Absolute Maximum Rating

Parameter	Rating
Operating Case Temperature	-40 to +85 °C
Storage Temperature	-55 to +150 °C

Operation of this device above any of these parameters may cause permanent damage.

Ordering Information

Part No.	Description
WJA1015	+5V Active Bias InGaP HBT Gain Block (lead-free/green/RoHS-compliant SOT-89 Package)
WJA1015-PCB	500 – 2400 MHz Fully Assembled Eval. Board

Specifications and information are subject to change without notice



WJA1015

+5V Active-Bias InGaP HBT Gain Block

Typical Device RF Performance

Supply Bias = +5 V, $I_{CC} = 67$ mA

1. Test conditions: $T = 25^\circ\text{C}$, Supply Voltage = +5 V, $I_{CC} = 67$ mA typical, $50\ \Omega$ System.
2. 3OIP measured with two tones at an output power of 0 dBm/tone separated by 1 MHz. The suppression on the largest IM3 product is used to calculate the 3OIP using a 2:1 rule.





WJA1015

+5V Active-Bias InGaP HBT Gain Block

Application Circuit

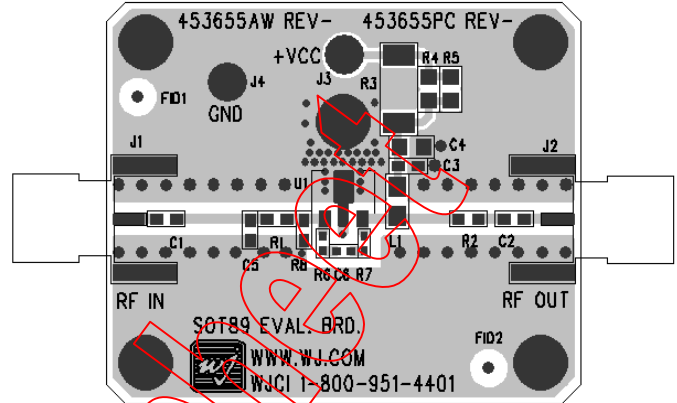
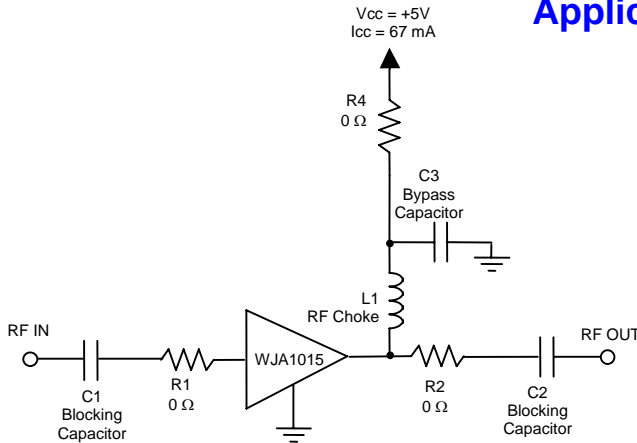

Recommended Component Values⁽¹⁾

Ref. Name	Value / Type	Size
L1	39 nH wire wound inductor	0805
C1, C2	56 pF chip capacitor	0603
C3	0.018 μ F chip capacitor	0603
R1, R2, R4	0 Ω ⁽²⁾	0603
C4, C5, C6, R3, R5, R6, R7, R8	Do Not Place ⁽²⁾	

1. The listed values are contained on the evaluation board to achieve optimal broadband performance
2. Place holders for the 0 Ω resistors and "Do Not Place" references are not needed for final design.

Typical Device Data

S-Parameters ($V_{device} = +5 V, I_{CC} = 63 mA, T = 25^{\circ}C$, calibrated to device leads)

Freq (MHz)	S11 (dB)	S11 (ang)	S21 (dB)	S21 (ang)	S12 (dB)	S12 (ang)	S22 (dB)	S22 (ang)
10	-10.31	-67.98	19.25	162.08	-21.70	25.28	-7.53	-51.14
50	-12.28	-146.51	15.39	164.52	-19.16	7.39	-14.79	-122.43
100	-12.50	-163.88	14.85	167.56	-18.95	2.89	-15.97	-143.83
300	-12.38	-177.31	14.58	161.11	-18.92	-2.40	-15.65	-154.89
500	-12.21	-176.67	14.44	151.08	-18.82	-6.24	-14.04	-152.65
700	-11.50	-169.56	14.40	140.65	-18.65	-9.72	-12.32	-153.10
900	-10.74	-163.56	14.14	130.95	-18.63	-13.66	-11.37	-157.97
1100	-9.86	-157.30	13.98	120.28	-18.53	-17.22	-10.37	-166.97
1300	-9.03	-150.21	13.78	110.73	-18.51	-21.91	-9.56	-175.43
1500	-8.47	-142.21	13.54	100.97	-18.40	-25.84	-8.54	-176.67
1700	-8.02	-132.62	13.31	91.65	-18.44	-29.93	-7.69	-171.36
1900	-7.70	-121.93	13.22	82.60	-18.46	-33.98	-6.98	-166.70
2100	-7.32	-112.83	13.10	72.93	-18.49	-37.81	-6.69	-162.83
2300	-6.82	-103.07	12.94	62.80	-18.55	-43.11	-6.47	-153.83
2500	-6.44	-95.12	12.84	52.81	-18.67	-47.20	-6.14	-143.36
2700	-5.90	-86.18	12.67	41.94	-18.78	-51.96	-5.63	-133.56
2900	-5.67	-76.21	12.43	31.85	-19.09	-55.24	-5.12	-126.58
3100	-5.66	-64.25	12.13	22.65	-19.19	-58.90	-4.72	-122.79
3300	-5.73	-53.11	11.93	12.59	-19.15	-60.53	-4.65	-121.06
3500	-6.02	-42.96	11.82	3.12	-19.16	-62.61	-4.93	-116.93
3700	-6.35	-33.94	11.71	-8.64	-19.03	-65.28	-5.11	-108.57
3900	-6.47	-25.50	11.43	-20.19	-19.02	-70.24	-5.06	-97.78
4100	-6.91	-12.96	10.83	-32.89	-19.04	-74.88	-4.70	-88.54
4300	-7.41	-1.03	10.17	-44.13	-19.04	-78.79	-4.34	-84.46
4500	-8.48	-14.39	9.69	-54.14	-18.89	-81.91	-4.14	-85.17



WJA1015

+5V Active-Bias InGaP HBT Gain Block

Mechanical Information

This package is lead-free/Green/RoHS-compliant. It is compatible with both lead-free (maximum 260 °C reflow temperature) and leaded (maximum 245 °C reflow temperature) soldering processes. The plating material on the leads is NiPdAu.

Outline Drawing

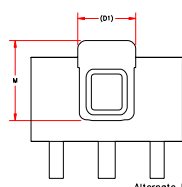
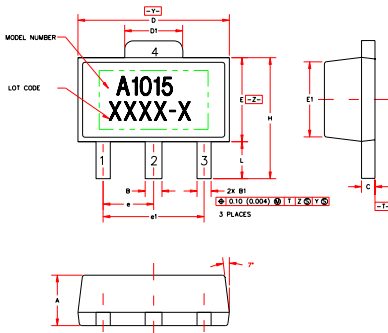

Alternate Backside Patterns
(May be supplied with either backside pattern as shown)

SYMBOL	MIN	NOM	MAX
A	1.40 (.055)	1.50 (.059)	1.65 (.065)
B	.44 (.017)	.50 (.020)	.56 (.022)
B1	.28 (.011)	.42 (.016)	.48 (.019)
C	.25 (.010)	.40 (.016)	.44 (.017)
D	4.40 (.173)	4.50 (.177)	4.60 (.181)
D1	1.62 (.064)	1.75 (.069)	.85 (.033)
E	2.29 (.090)	2.50 (.098)	2.80 (.110)
E1	2.13 (.084)	2.30 (.091)	2.39 (.094)

	1.50 BSC (.059)	3.00 BSC (.118)	4.25 (.167)
e	1.18	1.18	1.18
e1	3.94 (.155)	4.10 (.161)	4.25 (.167)
h	.89	.89	.89
l	1.05	1.05	1.05
m	2.4	2.40	2.5
m	1.87	(.075)	1.97

- NOTES:
 1. DIMENSIONS CONFORM WITH JEDEC TO-243C EXCEPT WHERE INDICATED.
 2. DIMENSIONS ARE COORDINATES IN MILLIMETERS (INCHES).
 3. DIMENSIONING AND TOLERANCING (AS APPLICABLE)

Product Marking

The WJA1015 will be marked with an "A1015" designator with an alphanumeric lot code marked below the part designator.

Tape and reel specifications for this part are located on the website in the "Application Notes" section.

MSL / ESD Rating



Caution! ESD sensitive device.

ESD Rating: Class 1C
 Value: Passes ≥ 1000V min.
 Test: Human Body Model (HBM)
 Standard: JEDEC Standard JESD22-A114

ESD Rating: Class IV
 Value: Passes ≥ 1000V min.
 Test: Charged Device Model (CDM)
 Standard: JEDEC Standard JESD22-C101

Land Pattern

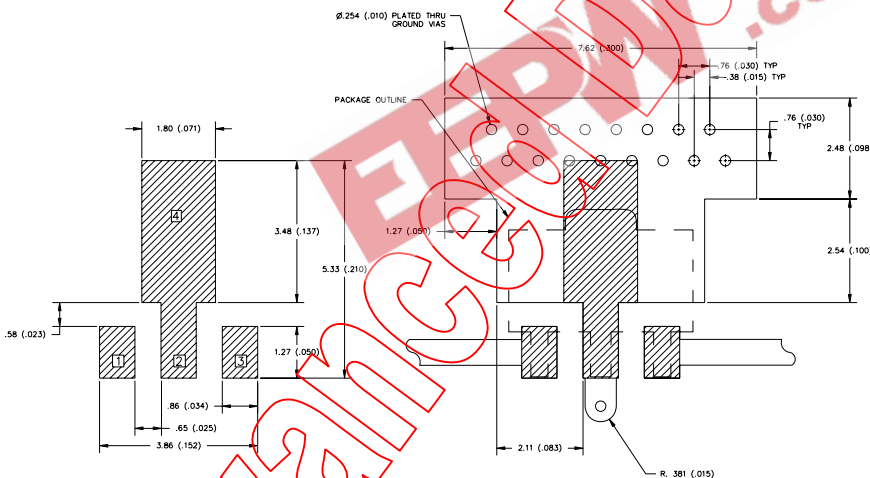

Mounting Config. Notes

1. Ground / thermal vias are critical for the proper performance of this device. Vias should use a .35mm (#80 / .0135") diameter drill and have a final plated thru diameter of .25 mm (.010").
2. Add as much copper as possible to inner and outer layers near the part to ensure optimal thermal performance.
3. Mounting screws can be added near the part to fasten the board to a heatsink. Ensure that the ground / thermal via region contacts the heatsink.
4. Do not put solder mask on the backside of the PC board in the region where the board contacts the heatsink.
5. RF trace width depends upon the PC board material and construction.
6. Use 1 oz. Copper minimum.
7. All dimensions are in millimeters (inches). Angles are in degrees.