



512Kx8 MONOLITHIC SRAM PRELIMINARY*

FEATURES

- Access Times 15, 17, 20ns
- Revolutionary, Center Power/Ground Pinout JEDEC Approved
 - 36 lead Ceramic SOJ (Package 100)
 - 36 lead Ceramic Flat Pack (Package 226)
- Evolutionary, Corner Power/Ground Pinout JEDEC Approved
 - 32 pin Ceramic DIP (Package 300)
 - 32 lead Ceramic SOJ (Package 101)**
 - 32 lead Ceramic Flat Pack (Package 220)**
- 32 pin, Rectangular Ceramic Leadless Chip Carrier (Package 601)

- Low Power CMOS
- Low Voltage Operation:
 - 3.3V ± 10% Power Supply
- Commercial, Industrial and Military Temperature Range
- TTL Compatible Inputs and Outputs
- Fully Static Operation:
 - No clock or refresh required.
- Three State Output.

* This data sheet describes a product that is not fully qualified or characterized and is subject to change without notice.

** Package under development.

REVOLUTIONARY PINOUT EVOLUTIONARY PINOUT

**36 FLAT PACK
36 CSOJ**

TOP VIEW

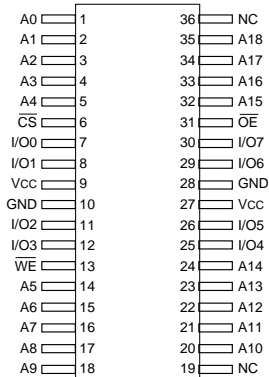

**32 DIP
32 CSOJ (DE)**
32 FLAT PACK (FE)****

TOP VIEW

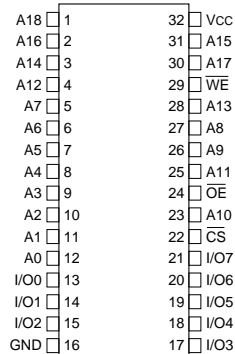

32 CLCC

TOP VIEW

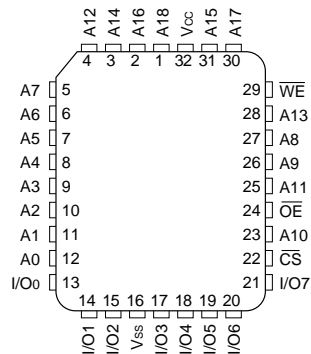

PIN DESCRIPTION

A0-18	Address Inputs
I/O0-7	Data Input/Output
CS	Chip Select
OE	Output Enable
WE	Write Enable
Vcc	Power Supply
GND	Ground



ABSOLUTE MAXIMUM RATINGS

Parameter	Symbol	Min	Max	Unit
Operating Temperature	T _A	-55	+125	°C
Storage Temperature	T _{STG}	-65	+150	°C
Signal Voltage Relative to GND	V _G	-0.5	4.6	V
Junction Temperature	T _J		150	°C
Supply Voltage	V _{CC}	-0.5	4.6	V

RECOMMENDED OPERATING CONDITIONS

Parameter	Symbol	Min	Max	Unit
Supply Voltage	V _{CC}	3.0	3.6	V
Input High Voltage	V _{IH}	2.2	V _{CC} + 0.3	V
Input Low Voltage	V _{IL}	-0.3	+0.8	V
Operating Temp. (Ind.)	T _A	-40	+85	°C

TRUTH TABLE

\overline{CS}	\overline{OE}	\overline{WE}	Mode	Data I/O	Power
H	X	X	Standby	High Z	Standby
L	L	H	Read	Data Out	Active
L	X	L	Write	Data In	Active
L	H	H	Out Disable	High Z	Active

CAPACITANCE

(T_A = +25°C)

Parameter	Symbol	Condition	Max	Unit
Input capacitance	C _{IN}	V _{IN} = 0V, f = 1.0MHz	12	pF
Output capacitance	C _{OUT}	V _{OUT} = 0V, f = 1.0MHz	12	pF

This parameter is guaranteed by design but not tested.

DC CHARACTERISTICS

(V_{CC} = 3.3V, GND = 0V, T_A = -55°C to +125°C)

Parameter	Sym	Conditions	Units		
			Min	Max	
Input Leakage Current	I _{LI}	V _{CC} = 3.6, V _{IN} = GND to V _{CC}		10	μA
Output Leakage Current	I _{LO}	$\overline{CS} = V_{IH}, \overline{OE} = V_{IH}, V_{OUT} = GND \text{ to } V_{CC}$		10	μA
Operating Supply Current	I _{CC}	$\overline{CS} = V_{IL}, \overline{OE} = V_{IH}, f = 5\text{MHz}, V_{CC} = 3.6$		100	mA
Standby Current	I _{SB}	$\overline{CS} = V_{IH}, \overline{OE} = V_{IH}, f = 5\text{MHz}, V_{CC} = 3.6$		50	mA
Output Low Voltage	V _{OL}	I _{OL} = 4.0mA		0.4	V
Output High Voltage	V _{OH}	I _{OH} = -4.0mA	2.4		V

NOTE: DC test conditions: V_{IH} = V_{CC} - 0.3V, V_{IL} = 0.3V

NOTE: Contact factory for low power option.



AC CHARACTERISTICS

(V_{CC} = 3.3V, GND = 0V, T_A = -55°C to +125°C)

Parameter	Symbol	-15		-17		-20		Units
		Min	Max	Min	Max	Min	Max	
Read Cycle								
Read Cycle Time	t _{RC}	15		17		20		ns
Address Access Time	t _{AA}		15		17		20	ns
Output Hold from Address Change	t _{OH}	0		0		0		ns
Chip Select Access Time	t _{ACS}		15		17		20	ns
Output Enable to Output Valid	t _{OE}		8		8		10	ns
Chip Select to Output in Low Z	t _{CLZ} ¹	1		1		1		ns
Output Enable to Output in Low Z	t _{OLZ} ¹	0		0		0		ns
Chip Disable to Output in High Z	t _{CHZ} ¹		8		8		10	ns
Output Disable to Output in High Z	t _{OHZ} ¹		8		8		10	ns

1. This parameter is guaranteed by design but not tested.

AC CHARACTERISTICS

(V_{CC} = 3.3V, GND = 0V, T_A = -55°C to +125°C)

Parameter	Symbol	-15		-17		-20		Units
		Min	Max	Min	Max	Min	Max	
Write Cycle								
Write Cycle Time	t _{WC}	15		17		20		ns
Chip Select to End of Write	t _{CW}	12		12		14		ns
Address Valid to End of Write	t _{AW}	12		12		14		ns
Data Valid to End of Write	t _{DW}	9		9		10		ns
Write Pulse Width	t _{WP}	12		14		14		ns
Address Setup Time	t _{AS}	0		0		0		ns
Address Hold Time	t _{AH}	0		0		0		ns
Output Active from End of Write	t _{OW} ¹	2		3		3		ns
Write Enable to Output in High Z	t _{WHZ} ¹		8		8		9	ns
Data Hold Time	t _{DH}	0		0		0		ns

1. This parameter is guaranteed by design but not tested.

AC TEST CIRCUIT

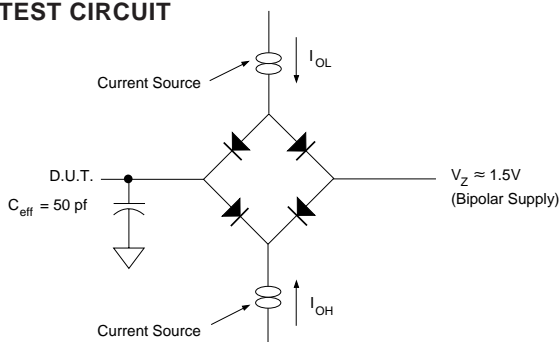

AC TEST CONDITIONS

Parameter	Typ	Unit
Input Pulse Levels	V _{IL} = 0, V _{IH} = 2.5	V
Input Rise and Fall	5	ns
Input and Output Reference Level	1.5	V
Output Timing Reference Level	1.5	V

NOTES:

V_Z is programmable from -2V to +7V.
 I_{OL} & I_{OH} programmable from 0 to 16mA.
 Tester Impedance Z₀ = 75 Ω.
 V_Z is typically the midpoint of V_{OH} and V_{OL}.
 I_{OL} & I_{OH} are adjusted to simulate a typical resistive load circuit.
 ATE tester includes jig capacitance.



TIMING WAVEFORM - READ CYCLE

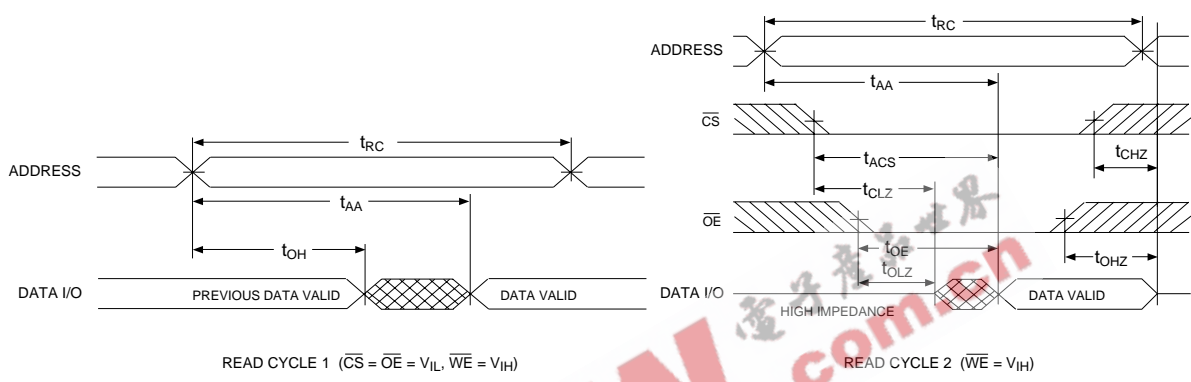

WRITE CYCLE - \overline{WE} CONTROLLED

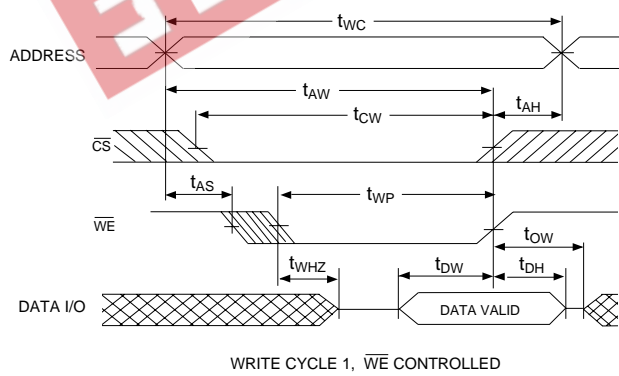

WRITE CYCLE - \overline{CS} CONTROLLED

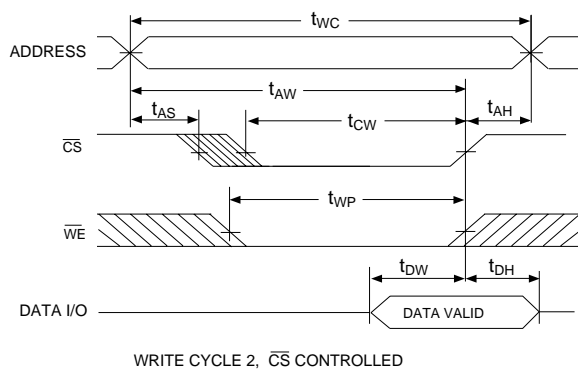



PACKAGE 100: 36 LEAD, CERAMIC SOJ



ALL LINEAR DIMENSIONS ARE MILLIMETERS AND PARENTHETICALLY IN INCHES

PACKAGE 101: 32 LEAD, CERAMIC SOJ



ALL LINEAR DIMENSIONS ARE MILLIMETERS AND PARENTHETICALLY IN INCHES



PACKAGE 220: 32 LEAD, CERAMIC FLAT PACK

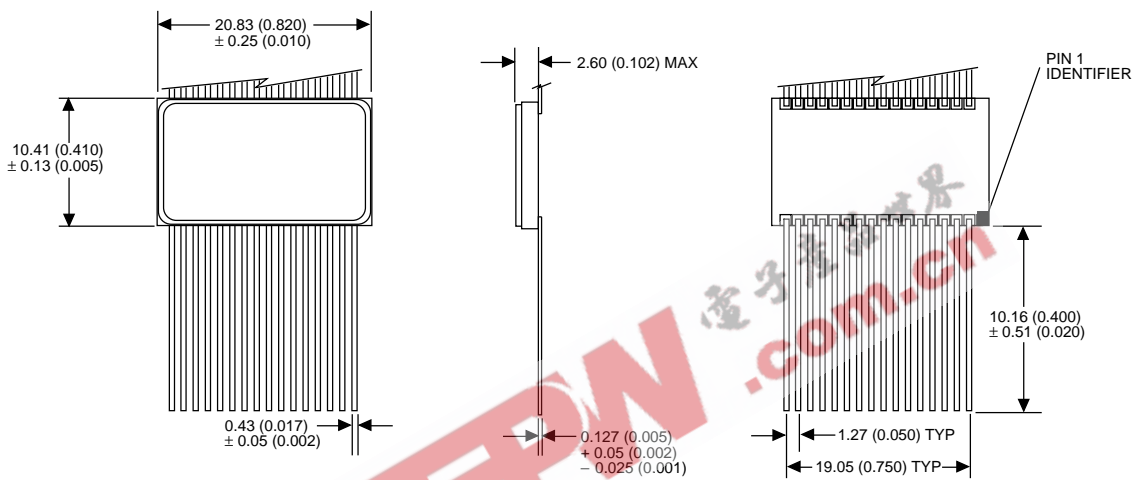

ALL LINEAR DIMENSIONS ARE MILLIMETERS AND PARENTHETICALLY IN INCHES

PACKAGE 226: 36 LEAD, CERAMIC FLAT PACK

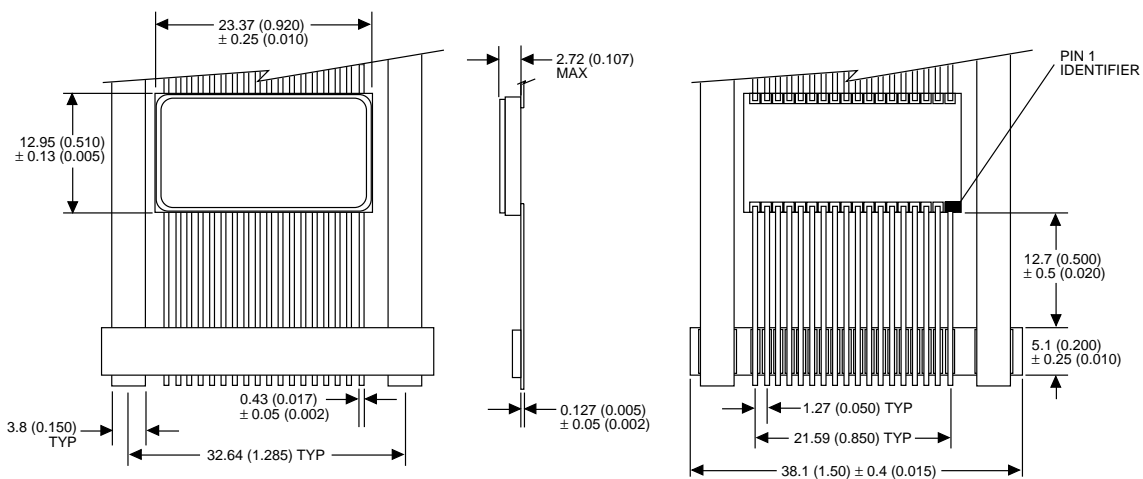

ALL LINEAR DIMENSIONS ARE MILLIMETERS AND PARENTHETICALLY IN INCHES



PACKAGE 300: 32 PIN, CERAMIC DIP, SINGLE CAVITY SIDE BRAZED



ALL LINEAR DIMENSIONS ARE MILLIMETERS AND PARENTHETICALLY IN INCHES



PACKAGE 601: 32 PIN, RECTANGULAR CERAMIC LEADLESS CHIP CARRIER

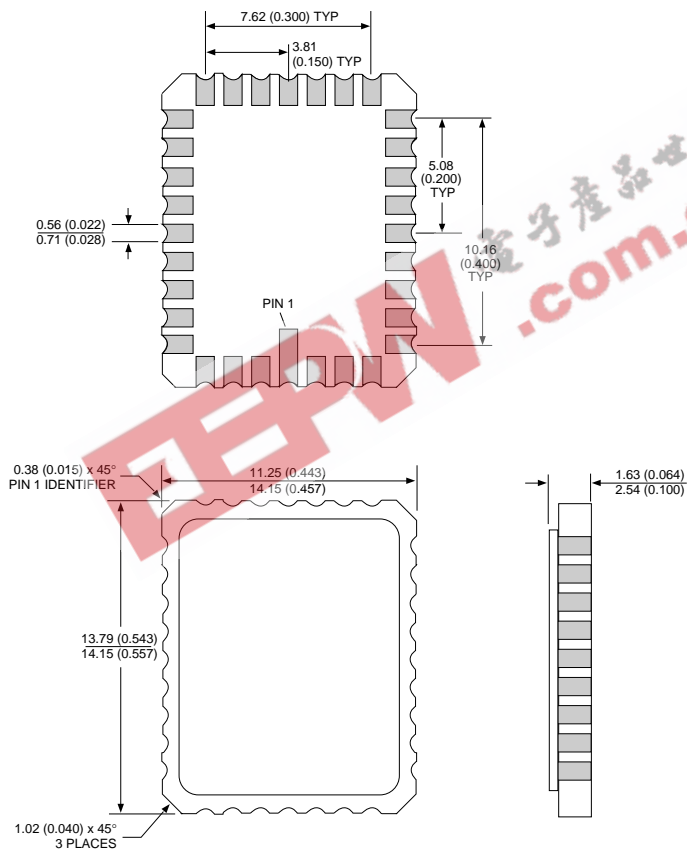

ALL LINEAR DIMENSIONS ARE MILLIMETERS AND PARENTHETICALLY IN INCHES



ORDERING INFORMATION

W M S 512K 8 V - XXX X X X

LEAD FINISH:

- Blank = Gold plated leads
- A = Solder dip leads

DEVICE GRADE:

- M = Military -55°C to +125°C
- I = Industrial -40°C to +85°C
- C = Commercial 0°C to +70°C

PACKAGE:

- C = 32 Pin Ceramic .600" DIP (Package 300)
- CL = 32 Pin Rectangular Ceramic Leadless Chip Carrier (Package 601)
- DE = 32 Lead Ceramic SOJ (Package 101) Evolutionary*
- DJ = 36 Lead Ceramic SOJ (Package 100)
- F = 36 Lead Ceramic Flat Pack (Package 226)
- FE = 32 Lead Ceramic Flat Pack (Package 220)*

ACCESS TIME (ns)

Low Voltage Supply 3.3V ± 10%

ORGANIZATION, 512K x 8

SRAM

MONOLITHIC

WHITE ELECTRONIC DESIGNS CORP.

* Package under development.