

192kHz, Six Channel SACD™ Compatible Audio DAC

DESCRIPTION

The WM8756 is a high performance 6-channel DAC designed for audio applications such as SACD™ players, DVD-V and DVD-A, home audio and theatre systems. The device supports data input word lengths from 16 to 32-bits and sampling rates up to 192kHz. The WM8756 can implement 2 or 6 channels at 192kHz for high-end DVD-Audio, or 6 channels at up to 192kHz for surround applications. Additionally 64x DSD bitstream support is offered on all 6 channels. The WM8756 consists of a serial interface port, digital interpolation filters, multi-bit sigma delta modulators and 6 DACs in a 48-pin TQFP package. The WM8756 also includes a digitally controllable mute and attenuator function on each channel, accessible during PCM operation. An on-chip multiplexer selects between PCM or DSD audio data input pins.

The WM8756 supports hardware or software connection schemes for audio DAC control. The serial control interface provides access to a wide range of features including on-chip mute, attenuation and phase reversal. Hardware pin-controllable operation is also available.

The WM8756 is an ideal device for all surround sound applications supporting the SACD™ audio format, such as SACD players, multi-format players and home entertainment systems.

FEATURES

- 6-Channel DAC with PCM or Bitstream (DSD) operation.
- DSD 64x Bitstream Support for Super Audio CD™
- Independent input pins for PCM and DSD data with on-chip multiplexer
- THD -96dB, SNR 106dB ('A' weighted @ 48kHz)
- PCM mode Sampling Rate: 8kHz – 192kHz
- Master or slave operation with Normal or Phase modulation method of DSD data transfer
- 3-Wire Serial Control Interface
- Programmable PCM Audio Data Interface Modes
 - I²S, Left, Right Justified or DSP
 - 16/20/24/32 bit Word Lengths
- Independent Digital Volume Control on Each Channel with 127.5dB Range in 0.5dB Steps (in PCM mode)
- 3.0V – 5.5V Supply (3.3V digital / 5V analogue option)
- 48-pin TQFP Package

APPLICATIONS

- Super Audio CD (SACD™) Players
- Universal and Multi-Format disc players
- Home theatre systems

BLOCK DIAGRAM

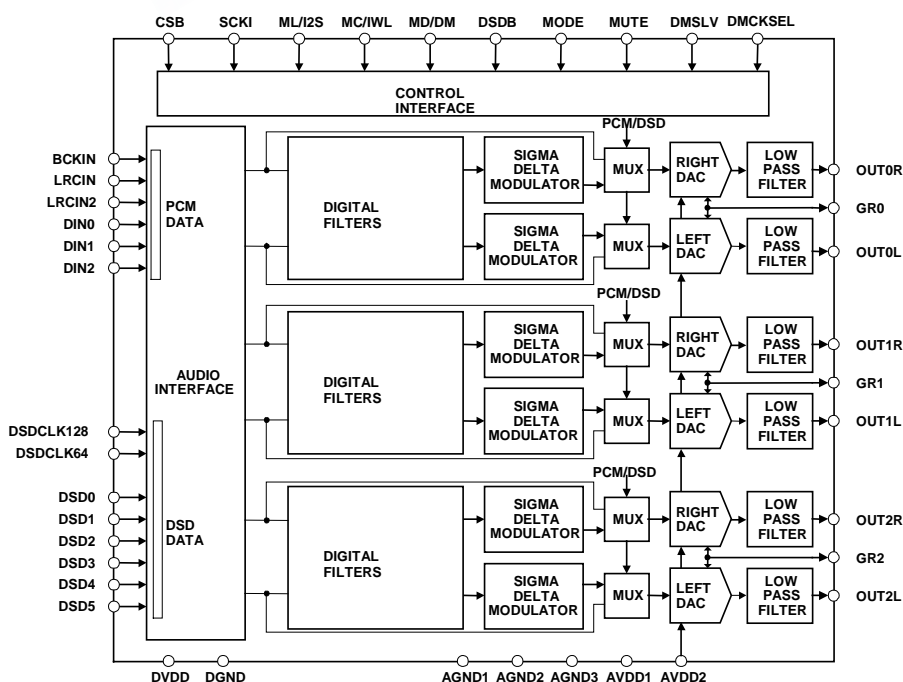

PIN CONFIGURATION

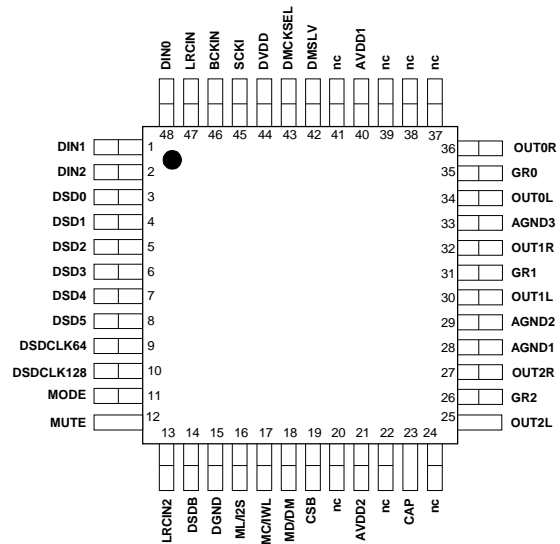

ORDERING INFORMATION

DEVICE	TEMP. RANGE	PACKAGE
WM8756EFT	-25 to +85°C	48-pin TQFP



PIN DESCRIPTION

PIN	NAME	TYPE	DESCRIPTION
1	DIN1	Digital input	Channel 1 Serial Audio Data Input in PCM Mode.
2	DIN2	Digital input	Channel 2 Serial Audio Data Input in PCM Mode.
3	DSD0	Digital input p.d.	Channel 0 Left DSD format audio data input
4	DSD1	Digital input p.d.	Channel 0 Right DSD format audio data input
5	DSD2	Digital input p.d.	Channel 1 Left DSD format audio data input
6	DSD3	Digital input p.d.	Channel 1 Right DSD format audio data input
7	DSD4	Digital input p.d.	Channel 2 Left DSD format audio data input
8	DSD5	Digital input p.d.	Channel 2 Right DSD format audio data input
9	DSDCLK64	Digital In/Out	DSD format data clock at 64fs
10	DSDCLK128	Digital In/Out	DSD format data clock at 128fs (used in 'modulated data' mode)
11	MODE	Digital input	Control Method Selection Pin in PCM Mode. 'lo' = software mode
12	MUTE	Digital In/Out	Mute Control Pin in PCM Mode. 'lo' = not muted
13	LRCIN2	Digital input p.d.	Second LRCIN input for dual rate mode
14	DSDB	Digital input p.u.	DSD or PCM audio data format select; 'lo' = DSD mode, 'hi' = PCM mode
15	DGND	Supply	Digital GND
16	ML/I2S	Digital input p.u.	Software mode: in 3-Wire Serial Control mode, Latch input. Hardware Mode: Input Format Selection:
17	MC/IWL	Digital input p.u.	Software Mode: In 3-Wire Serial Control Mode, Clock Input. Hardware mode: Input Word Length Selection:
18	MD/DM	Digital input	Software mode: In 3-Wire Serial Control Mode, Data Input. Hardware mode: De-emphasis selection
19	CSB	Digital input p.d.	3-wire Serial Port Chip select – active low
20	n.c.	n.c.	No internal connection
21	AVDD2	Supply	Analogue Positive DAC Reference
22	n.c.	n.c.	No internal connection
23	CAP	Analogue output	Analogue Internal Mid-Rail Reference De-Coupling Point
24	n.c.	n.c.	No internal connection
25	OUT2L	Analogue output	Left Channel 2 Output.
26	GR2	Analogue input	Channel 2 Negative Reference.
27	OUT2R	Analogue output	Right Channel 2 Output.
28	AGND1	Supply	Analogue GND
29	AGND2	Supply	Analogue GND
30	OUT1L	Analogue output	Left Channel 1 Output.
31	GR1	Analogue input	Channel 1 Negative Reference.
32	OUT1R	Analogue output	Right Channel 1 Output.
33	AGND3	Supply	Analogue GND
34	OUT0L	Analogue output	Left Channel 0 Output.
35	GR0	Analogue input	Channel 0 Negative Reference.
36	OUT0R	Analogue output	Right Channel 0 Output.
37-39	nc	nc	No internal connection
40	AVDD1	Supply	Analogue positive supply
41	nc	nc	No internal connection
42	DMSLV	Digital input p.d.	DSD mode master or slave operation select; 'lo' = SLAVE (clocks are input)
43	DMCKSEL	Digital input p.d.	DSD Master Mode Clock Select (lo for 256fs; hi for 384fs)
44	DVDD	Supply	Digital Positive Supply.
45	SCKI	Digital input	Master Clock Input
46	BCKIN	Digital input	Audio Data Bit Clock Input.
47	LRCIN	Digital input	DAC Sample Rate Clock Input in PCM Mode
48	DIN0	Digital input	Channel 0 Serial Audio Data Input in PCM Mode.

Note - Digital input pins have Schmitt trigger input buffers. Pins marked 'p.u.' or 'p.d.' have internal pull-up or pull down.

ABSOLUTE MAXIMUM RATINGS

Absolute Maximum Ratings are stress ratings only. Permanent damage to the device may be caused by continuously operating at or beyond these limits. Device functional operating limits and guaranteed performance specifications are given under Electrical Characteristics at the test conditions specified.



ESD Sensitive Device. This device is manufactured on a CMOS process. It is therefore generically susceptible to damage from excessive static voltages. Proper ESD precautions must be taken during handling and storage of this device.

CONDITION	MIN	MAX
Digital supply voltage	-0.3V	+7V
Analogue supply voltage	-0.3V	+7V
Voltage range digital inputs	DGND -0.3V	DVDD +0.3V
Voltage range analogue inputs	AGND -0.3V	AVDD +0.3V
Master Clock Frequency		37MHz
Operating temperature range, T _A	-25°C	+85°C
Storage temperature	-65°C	+150°C
Lead temperature (soldering 10 seconds)		+240°C
Lead temperature (soldering 2 minutes)		+183°C

Table 1 Absolute maximum ratings

DC ELECTRICAL CHARACTERISTICS

PARAMETER	SYMBOL	TEST CONDITIONS	MIN	TYP	MAX	UNIT
Digital supply range	DVDD		3.0		5.5	V
Analogue supply range	AVDD		3.0		5.5	V
Ground	AGND, DGND			0		V
Difference of DGND to AGND			-0.3	0	+0.3	V
Difference of GR to AGND			-0.3	0	+0.3	V
Analogue supply current		AVDD = 5V		58		mA
Digital supply current		DVDD = 5V		22		mA
Analogue supply current		AVDD = 3.3V		57		mA
Digital supply current		DVDD = 3.3V		11		mA
Analogue supply current		Power down, stop clock		0.4		mA
Digital supply current		Power down, stop clock		0.09		mA

Table 2 DC electrical characteristics

Note:

1. AVDD must be equal or greater than DVDD. DVDD = 3V, AVDD = 5V is allowed.
2. Where used AVDD represents AVDD1 = AVDD2, AGND represents AGND1 = AGND2 = AGND3 and GR represents GR0 = GR1 = GR2.

AC ELECTRICAL CHARACTERISTICS

Test Conditions

AVDD = DVDD = 3V, AGND = 0V = DGND = 0V, $T_A = +25^\circ\text{C}$, $f_s = 48\text{kHz}$, SCKI = 256fs unless otherwise stated.

PARAMETER	SYMBOL	TEST CONDITIONS	MIN	TYP	MAX	UNIT
Digital Logic Levels (TTL Levels)						
Input LOW level	V_{IL}				0.8	V
Input HIGH level	V_{IH}		2.0			V
Output LOW	V_{OL}	$I_{OL} = 2\text{mA}$			0.4	V
Output HIGH	V_{OH}	$I_{OH} = 2\text{mA}$	2.4			V
Analogue Reference Levels						
Reference voltage	V_{CAP}			AVDD2 – GR2/2		V
Potential divider resistance	R_{CAP}			25K		Ohms
DAC Output (Load = 10K ohms. 50pF)						
0dBfs Full scale output voltage		At DAC outputs		1.1 x AVDD1/5		V_{rms}
SNR (Note 1,2,3)		A-weighted, @ $f_s = 48\text{KHz}$	100	106		dB
SNR (Note 1,2,3)		A-weighted @ $f_s = 96\text{KHz}$	98	105		dB
SNR (Note 1,2,3)		A-weighted @ $f_s = 192\text{KHz}$		105		dB
SNR (Note 1,2,3)		A-weighted, @ $f_s = 48\text{KHz}$ AVDD=DVDD=3.3V		103		dB
SNR (Note 1,2,3)		A-weighted @ $f_s = 96\text{KHz}$ AVDD=DVDD=3.3V		103		dB

Test ConditionsAVDD = DVDD = 3V, AGND = 0V = DGND = 0V, T_A = +25°C, f_s = 48kHz, SCKI = 256fs unless otherwise stated.

PARAMETER	SYMBOL	TEST CONDITIONS	MIN	TYP	MAX	UNIT
SNR (Note 1,2,3)		Non 'A' weighted @ f _s = 48kHz AVDD=DVDD=5V		103		dB
THD (Note 1,2,3)		1KHz, 0dBFS	-90	-95		dB
THD+N (Dynamic range, Note 2)		1kHz, -60dBFS	100	-106		dB
DAC channel separation				<95		dB
Analogue Output Levels						
Output level		Load = 10k ohms, 0dBFS		1.1		V _{rms}
		Load = 10k ohms, 0dBFS, (AVDD = 3.3V)		0.73		V _{rms}
Gain mismatch channel-to-channel				±1		%FSR
Minimum resistance load		To midrail or a.c. coupled		1		kOhms
		To midrail or a.c. coupled (AVDD = 3.3V)		1		kOhms
Maximum capacitance load		5V or 3.3V		100		pF
Output d.c. level				AVDD1- AGND/2		V
Power On Reset (POR)						
POR threshold				2.0		V

Table 3 AC Electrical Characteristics**Notes:**

- Ratio of output level with 1kHz full scale input, to the output level with all zeros into the digital input, measured 'A' weighted over a 20Hz to 20kHz bandwidth.
- All performance measurements done with 20kHz low pass filter, and where noted an A-weight filter. Failure to use such a filter will result in higher THD+N and lower SNR and Dynamic Range readings than are found in the Electrical Characteristics. The low pass filter removes out of band noise; although it is not audible it may affect dynamic specification values.
- CAP decoupled with 10uF and 0.1uF capacitors (smaller values may result in reduced performance).

DIGITAL FILTER CHARACTERISTICS

PARAMETER	SYMBOL	TEST CONDITIONS	MIN	TYP	MAX	UNIT
Passband		± 0.05 dB	0.444fs			dB
Stopband		-3dB		0.487fs		
Passband Ripple					± 0.05	dB
Stopband Attenuation		$f > 0.555$ fs			-60	dB

Table 4 Digital Filter Characteristics – PCM operation

SACD FILTER CHARACTERISTICS

With 64fs DSD data where $f_s = 44.1$ ks/s.

RESPONSE	FILTER RESPONSE WITHOUT POST-FILTER	FILTER RESPONSE WITH 3 RD ORDER BUTTERWORTH POST-FILTER (-3dB AT 55KHZ)
Pass band peak ripple	0.017dB	0.017dB
Attenuation at 20kHz	-0.012dB	-0.021dB
Attenuation at 50kHz	-2.3dB	-3.9dB
Attenuation at 100kHz	-15.5dB	-31dB

Table 5 Overall frequency response in SACD mode.

TERMINOLOGY

1. Signal-to-noise ratio (dB) - SNR is a measure of the difference in level between the full scale output and the output with no signal applied. (No Auto-zero or Automute function is employed in achieving these results).
2. Dynamic range (dB) - DNR is a measure of the difference between the highest and lowest portions of a signal. Normally a THD+N measurement at 60dB below full scale. The measured signal is then corrected by adding the 60dB to it. (e.g. THD+N @ -60dB= -32dB, DR= 92dB).
3. THD+N (dB) - THD+N is a ratio, of the rms values, of (Noise + Distortion)/Signal.
4. Stop band attenuation (dB) - Is the degree to which the frequency spectrum is attenuated (outside audio band).
5. Channel Separation (dB) - Also known as Cross-Talk. This is a measure of the amount one channel is isolated from the other. Normally measured by sending a full scale signal down one channel and measuring the other.
6. Pass-Band Ripple - Any variation of the frequency response in the pass-band region.

MASTER CLOCK TIMING

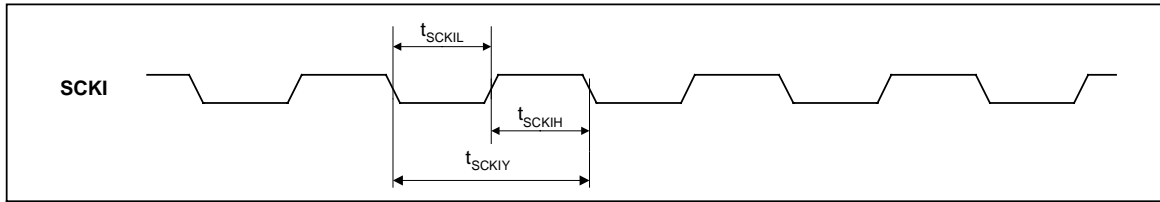

Figure 1 Master Clock Timing Requirements

Test Conditions

AVDD = DVDD = 5V, AGND = GR = DGND = 0V, $T_A = +25^\circ\text{C}$, $f_s = 48\text{kHz}$, SCKI = 256fs unless otherwise stated.

PARAMETER	SYMBOL	TEST CONDITIONS	MIN	TYP	MAX	UNIT
System Clock Timing Information						
SCKI System clock pulse width high	t_{SCKIH}		13			ns
SCKI System clock pulse width low	t_{SCKIL}		13			ns
SCKI System clock cycle time	t_{SCKIY}		26			ns
SCKI Duty cycle			40:60		60:40	

Table 6 Master Clock Timing Requirements

DIGITAL AUDIO INTERFACE TIMING

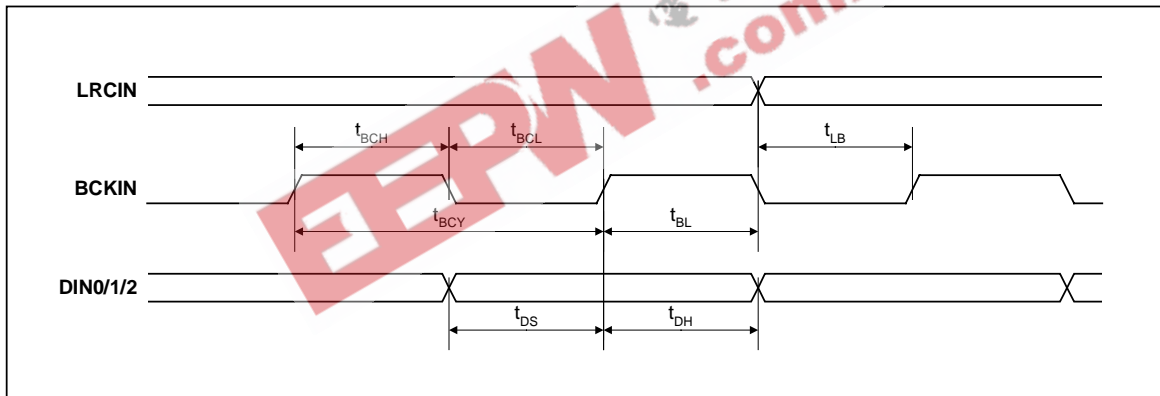

Figure 2 PCM Digital Audio Data Timing

Test Conditions

AVDD = DVDD = 5V, AGND = GR = DGND = 0V, $T_A = +25^\circ\text{C}$, $f_s = 48\text{kHz}$, SCKI = 256fs unless otherwise stated.

PARAMETER	SYMBOL	TEST CONDITIONS	MIN	TYP	MAX	UNIT
Audio Data Input Timing Information						
BCKIN cycle time	t_{BCY}		40			ns
BCKIN pulse width high	t_{BCH}		16			ns
BCKIN pulse width low	t_{BCL}		16			ns
LRCIN set-up time to BCKIN rising edge	t_{LB}		8			ns
LRCIN hold time from BCKIN rising edge	t_{BL}		8			ns
DIN0/1/2 set-up time to BCKIN rising edge	t_{DS}		8			ns
DIN0/1/2 hold time from BCKIN rising edge	t_{DH}		8			ns

Table 7 PCM Digital Audio Timing

DSD AUDIO MONOPHASE INTERFACE

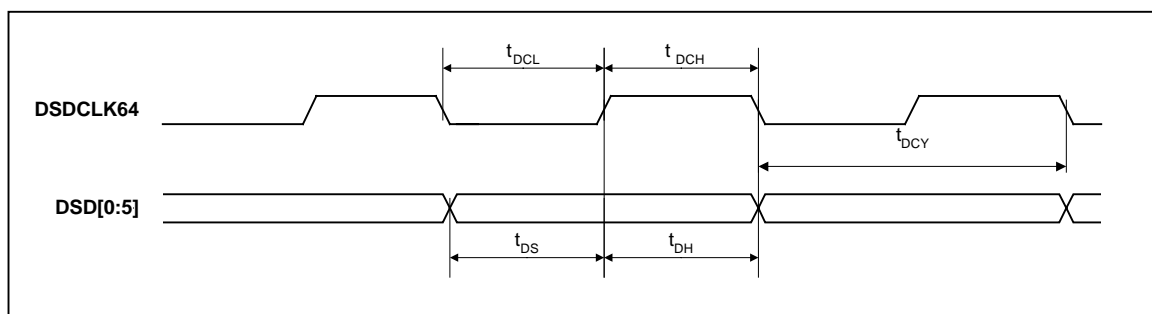

Figure 3 DSD Audio Data Timing – Normal Mode

Test Conditions

AVDD = DVDD = 5V, AGND = GR = DGND = 0V, $T_A = +25^\circ\text{C}$, $f_s = 48\text{kHz}$, SCKI = 256fs unless otherwise stated.

PARAMETER	SYMBOL	TEST CONDITIONS	MIN	TYP	MAX	UNIT
Audio Data Input Timing Information						
DSDCLK64 cycle time	t_{DCY}			354.4		ns
DSDCLK64 pulse width high	t_{DCH}		80			ns
DSDCLK64 pulse width low	t_{DCL}		80			ns
DSD[5:0] set-up time to DSDCLK64 rising edge	t_{DS}		10			ns
DSD[5:0] hold time from DSDCLK64 rising edge	t_{DH}		10			ns

Table 8 DSD Audio Data Timing – Normal Mode

DSD AUDIO BIPHASE INTERFACE

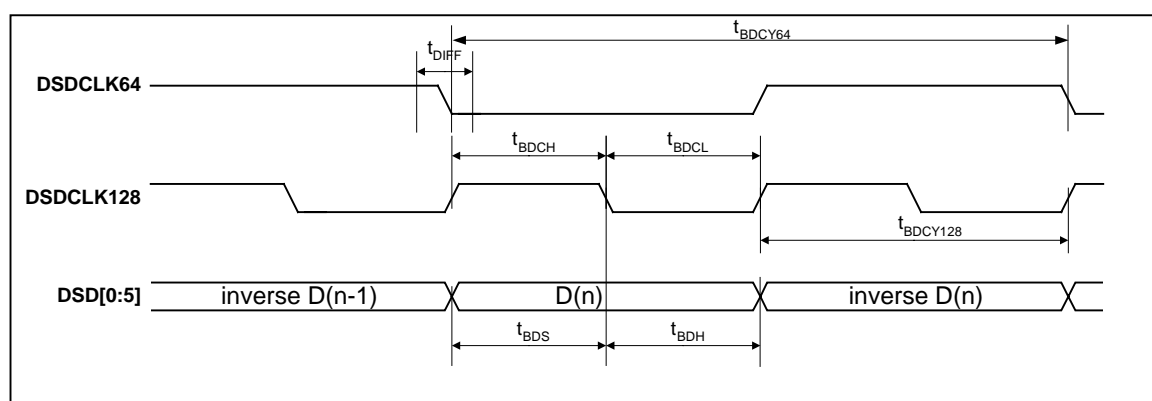

Figure 4 DSD Audio Data Timing - Phase Modulation Mode

Test Conditions

AVDD= DVDD = 5V, AGND= GR= DGND = 0V, T_A = +25°C, fs = 48kHz, SCKI = 256fs unless otherwise stated.

PARAMETER	SYMBOL	TEST CONDITIONS	MIN	TYP	MAX	UNIT
Audio Data Input Timing Information						
DSDCLK64 cycle time	t _{BDCY64}			354.4		ns
DSDCLK128 cycle time	t _{BDCY128}			177.2		ns
DSDCLK128 pulse width high	t _{BDCH}		80			ns
DSDCLK128 pulse width low	t _{BDCL}		80			ns
DSD[0:5] set-up time to DSDCLK128 rising edge	t _{BDS}		10			ns
DSD[0:5] hold time from DSDCLK128 rising edge	t _{BDH}		10			ns
Difference in edge timing of DSDCLK64 to DSDCLK128	t _{DIFF}				20	ns

Table 9 DSD Digital Audio Timing

DIGITAL CONTROL INTERFACE TIMING

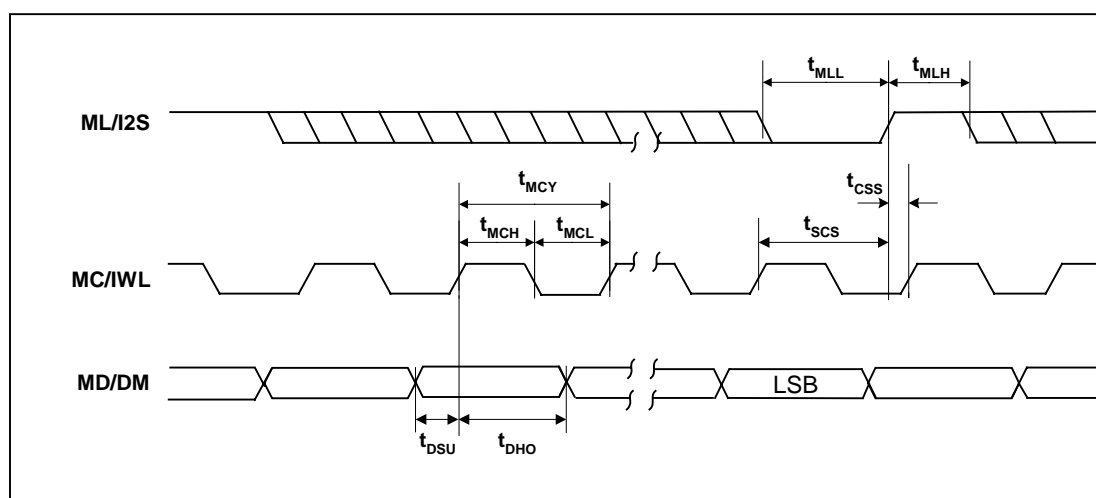

Figure 5 Control Interface Input Timing: 3-Wire Serial Control Mode

Test Conditions						
AVDD= DVDD = 5V, AGND= GR= DGND = 0V, T _A = +25°C, fs = 48kHz, SCKI = 256fs unless otherwise stated.						
PARAMETER	SYMBOL	TEST CONDITIONS	MIN	TYP	MAX	UNIT
Program Register Input Information						
MC/IWL rising edge to ML/I2S rising edge	t _{SCS}		60			ns
MC/IWL pulse cycle time	t _{MCY}		80			ns
MC/IWL pulse width low	t _{MCL}		20			ns
MC/IWL pulse width high	t _{MCH}		20			ns
MD/DM to MC/IWL set-up time	t _{DSU}		20			ns
MC/IWL to MD/DM hold time	t _{DHO}		20			ns
ML/I2S pulse width low	t _{MLL}		20			ns
ML/I2S pulse width high	t _{MLH}		20			ns
ML/I2S rising to MC/IWL rising	t _{CSS}		20			ns

Table 10 Control Interface Input Timing Information

DEVICE DESCRIPTION

INTRODUCTION

WM8756 is a complete 6-channel stereo audio digital-to-analogue converter, including digital interpolation filter, multi-bit sigma delta with dither, and switched capacitor multi-bit stereo DAC and output smoothing filters.

The device is implemented as three separate stereo DACs in a single package and controlled by a single interface. Each DAC has its own data input DIN0/1/2, and LRCIN, BCKIN and SCKI are shared between them. Additionally DSD compatible bitstream operation at 64x oversampling is supported on all 6 channels. Selection of normal PCM operation or this additional DSD mode is determined by the input level on the DSDB pin (14).

Control of internal functionality of the device is by either hardware control (pin programmed) or software control (3-wire serial control interface). The MODE pin selects between hardware and software control. In software control mode, a 3 wire SPI type interface is used. This interface may be asynchronous to the audio data interface. Control data will be re-synchronized to the audio processing internally.

Operation using a system clock of 256fs, 384fs or 512fs is provided, selection between clock rates being automatically controlled in hardware mode, or serially controlled when in software mode. Sample rates (fs) from less than 8ks/s to 96ks/s are allowed, provided the appropriate system clock is input. Support is also provided for up to 192ks/s using a system clock of 128fs or 192fs.

In normal PCM mode, the audio data interface supports right, left and I²S (Philips left justified, one bit delayed) interface formats along with a highly flexible DSP serial port interface. When in hardware mode, the three serial interface pins become control pins to allow selection of input data format type (I²S or right justified), input word length (16, 20, 24, or 32-bit) and de-emphasis functions.

In DSD mode, a separate bitstream data input pin is required for each of the 6 channels, plus a 64fs dataclock DSDCLK64. These signals are applied via separate pins (pins 3-9) and the signals multiplexed internally into the DAC circuits, under control of the DSDB mode select pin (14).

Additionally in DSD mode, a Phase Modulation scheme is supported, where the audio data is transmitted as a Manchester type, bi-phase encoded bitstream. This has the advantage of removing the significant audio spectral energy from the datastream, so minimising digital signal corruption of the analogue outputs. In order to simplify decoding of this phase modulated data, a 2x speed clock (DSDCLK128) is used to sample the incoming data. This 'modulated' mode is auto-detected from the presence of a clock signal on the DSDCLK128 pin.

In DSD mode, clocks for the DAC can be inputs (WM8756 in SLAVE mode) or outputs (WM8756 in MASTER mode). When clocks are outputs, SCKI remains an input, the lower rate clocks being derived by dividing this master clock signal. Depending upon the setting on the DMCKSEL pin, a master clock of either 256fs or 384fs may be used as input, from which the DSD clocks will be derived appropriately.

AUDIO DATA SAMPLING RATES

In a typical digital audio system there is only one central clock source producing a reference clock to which all audio data processing is synchronised. This clock is often referred to as the audio system's Master Clock. The external master system clock can be applied directly through the SCKI input pin with no software configuration necessary. Note that on the WM8756, SCKI is used to derive clocks for the DAC path. The DAC path consists of DAC sampling clock, DAC digital filter clock and DAC digital audio interface timing. In a system where there are a number of possible sources for the reference clock it is recommended that the clock source with the lowest jitter be used to optimise the performance of the DAC.

The system clock for WM8756 supports audio sampling rates from 128fs to 768fs, where fs is the audio sampling frequency (LRCIN) typically 32kHz, 44.1kHz, 48kHz, 96kHz or 192kHz. The system clock is used to operate the digital filters and the noise shaping circuits.

The WM8756 has a system clock detection circuit that automatically determines the relationship between the system clock frequency and the sampling rate (to within +/- 32 system clocks). If greater than 32 clocks error, the interface switches to 768fs and holds the output at the level of the last sample. The system clock should be synchronised with LRCIN, although the WM8756 is tolerant of phase differences or jitter on this clock. Table 11 shows the typical system clock frequency inputs for the WM8756.

SAMPLING RATE (LRCIN)	SYSTEM CLOCK FREQUENCY (MHZ)					
	128fs	192fs	256fs	384fs	512fs	768fs
32kHz	4.096	6.144	8.192	12.288	16.384	24.576
44.1kHz	5.6448	8.467	11.2896	16.9340	22.5792	33.8688
48kHz	6.114	9.216	12.288	18.432	24.576	36.864
96kHz	12.288	18.432	24.576	36.864	Unavailable	Unavailable
192kHz	24.576	36.864	Unavailable	Unavailable	Unavailable	Unavailable

Table 11 System Clock Frequencies Versus Sampling Rate

DSD MODE

When pin 14, DSDB pin is held low, the device is reconfigured to operate as a DSD or 'bitstream' compatible DAC. That is, the input audio data is in a sigma delta modulated form, or pulse density modulated. In this case the only signals required are the bitstream for each channel supported, and the oversampling clock.

WM8756 supports this mode when run at a 64x oversample rate. That is, the bitstream data is supplied at a rate of 64 bits per normal word clock. Of course no word clock is provided, and the actual spectral content of the data is determined by the noise shaping that was used to create the bitstream. WM8756 can support six channels of bitstream or DSD audio. Data BITSTREAMS and the 64fs clock are applied to pins 3-9 and 10, if the DSDCLK128 pin is used. Signals applied to the PCM input pins 1,2, 45-48 are ignored. The DSDB signal controls an internal multiplexor which switches the signals on the DSD input pins into the DAC rather than the PCM signals.

In DSD mode operation, the entire digital filter on WM8756 is disabled, and the bitstream data is applied directly to the multi-bit switched capacitor DAC's in the analogue part of the device. There, rather than operate as oversampled multi bit DACs, the DAC inputs are reconfigured to act as analogue FIR filters, so providing both D to A conversion of the bitstream data, and analogue smoothing of the sampled waveform with no phase distortion. Filter responses of the analogue filter that results are shown in Figure 26 - Figure 29. Note in DSD mode software controlled functions such as digital volume control and phase reversal, are not available. The FIR filter response is designed such that by adding only a 3rd order Butterworth type post DAC filter, which may be implemented with a single op-amp, the Scarlet book specified filter requirements may be met, saving cost over the 5th order filter normally needed.

It is normally desirable to use an external analogue post-DAC filter, particularly in the case of DSD operation due to the presence of high frequency energy as a result of the aggressive high order noise shaping used in the creation of the modulated DSD datastream. The analogue FIR filter used in WM8756 provides useful filtering of this noise, but it may be desirable to add further post filtering using active RC filters. Figure 26 - Figure 29 show the overall filter response of the combined DAC filter operating in DSD mode with an external 3rd order Butterworth active RC post-DAC filter.

PCM DIGITAL AUDIO INTERFACE

PCM audio data is applied to the internal DAC filters via the PCM Digital Audio Interface. 5 popular interface formats are supported:

- Left Justified mode
- Right Justified mode
- I²S mode
- DSP Early mode
- DSP Late mode

All 5 formats send the MSB first and support word lengths of 16, 20, 24 and 32 bits except that 32 bit data is not supported in right justified mode. DIN0/1/2 and LRCIN are sampled on the rising, or falling edge of BCKIN.

In left justified, right justified and I²S modes, the digital audio interface receives data on the DIN0/1/2 inputs. Audio Data for each stereo channel is time multiplexed with LRCIN indicating whether the left or right channel is present. LRCIN is also used as a timing reference to indicate the beginning or end of the data words.

In left justified, right justified and I²S modes, the minimum number of BCKINS per LRCIN period is 2 times the selected word length. LRCIN must be high for a minimum of word length BCKINS and low for a

minimum of word length BCKINs. Any mark to space ratio on LRCIN is acceptable provided the above requirements are met. The WM8756 will automatically detect when data with a LRCIN period of exactly 32 is sent, and select 16 bit mode - overriding any previously programmed word length. Word length will revert to the previously programmed value if a LRCIN period other than 32 is detected.

In DSP early or DSP late mode, all 6 channels are time multiplexed onto DIN0. LRCIN is used as a frame sync signal to identify the MSB of the first word. The minimum number of BCKINs per LRCIN period is 6 times the selected word length. Any mark to space ratio is acceptable on LRCIN provided the rising edge is correctly positioned (see Figures 9 and 10).

LEFT JUSTIFIED MODE

In left justified mode, the MSB is sampled on the first rising edge of BCKIN following a LRCIN transition. LRCIN is high during the left samples and low during the right samples.

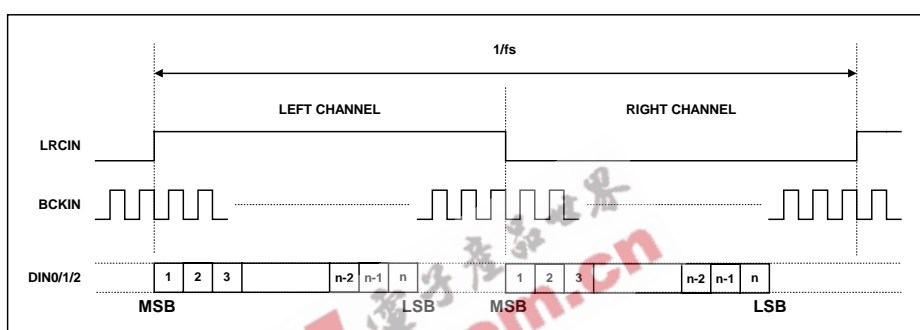

Figure 6 Left Justified Mode Timing Diagram

RIGHT JUSTIFIED MODE

In right justified mode, the LSB is sampled on the rising edge of BCKIN preceding a LRCIN transition. LRCIN is high during the left samples and low during the right samples.

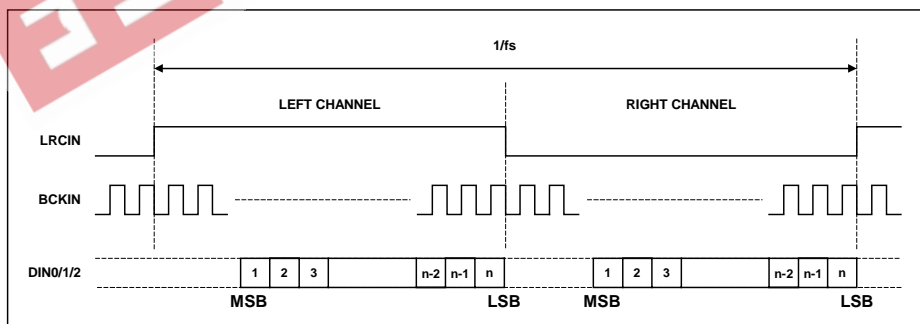

Figure 7 Right Justified Mode Timing Diagram

I²S MODE

In I²S mode, the MSB is sampled on the second rising edge of BCKIN following a LRCIN transition. LRCIN is low during the left samples and high during the right samples.

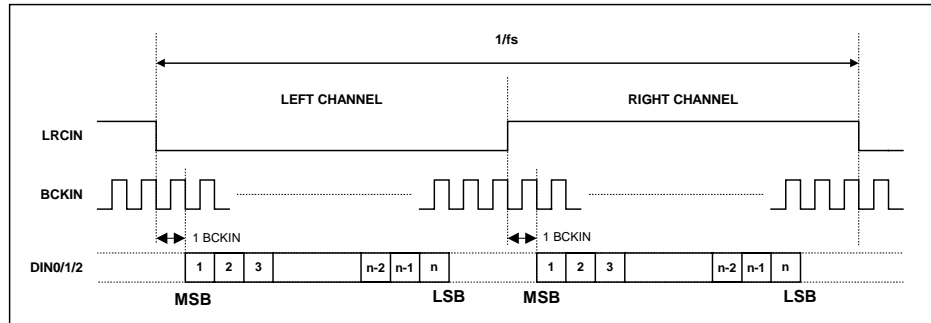

Figure 8 I²S Mode Timing Diagram

DSP EARLY MODE

In DSP early mode, the first bit is sampled on the BCKIN edge following the one which detects a low to high transition on LRCIN.

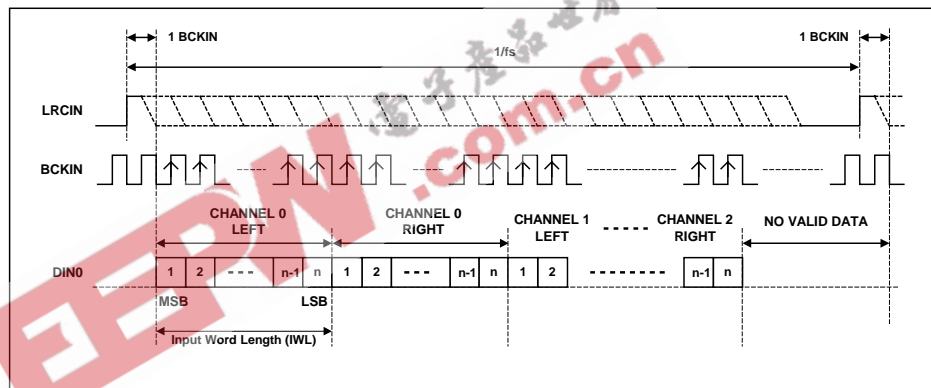

Figure 9 DSP Early Mode Timing Diagram

DSP LATE MODE

In DSP late mode, the first bit is sampled on the BCKIN edge which detects a low to high transition on LRCIN.

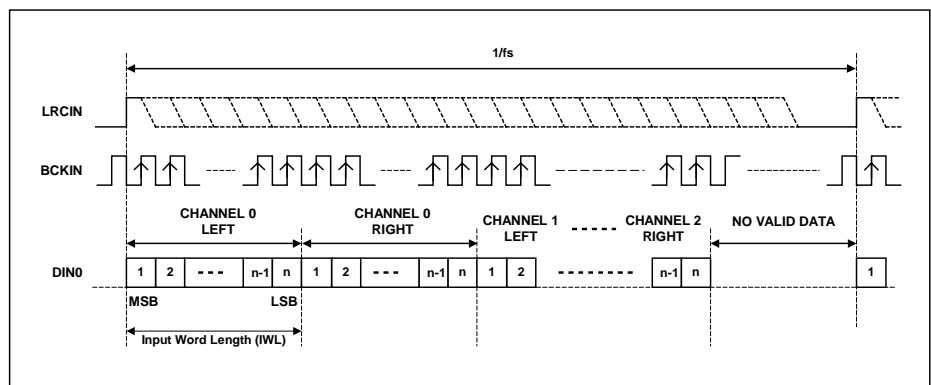

Figure 10 DSP Late Mode Timing Diagram

In both early and late DSP modes, DAC0 left is always sent first, followed immediately by data words for the other 5 channels. No BCKIN edges are allowed between the data words. The word order is DAC0 left, DAC0 right, DAC1 left, DAC1 right, DAC2 left, DAC2 right.

SPLIT RATE MODE

The WM8756 can be used with differing sample rates on the front and rear channels. This allows extremely high quality audio to be played on the front two channels whilst the other channels use normal high quality data streams.

This mode will only work with a front data rate of 192kHz and a rear rate of 96kHz but can be used with all the normal data formats **except** the two DSP modes and with the system at either 128fs or 192fs see Figure 11.

When running in split rate mode all the channels are clocked in using a common BCKIN; the front channels using LRCIN and all the other channels using LRCIN2 see Figure 11.

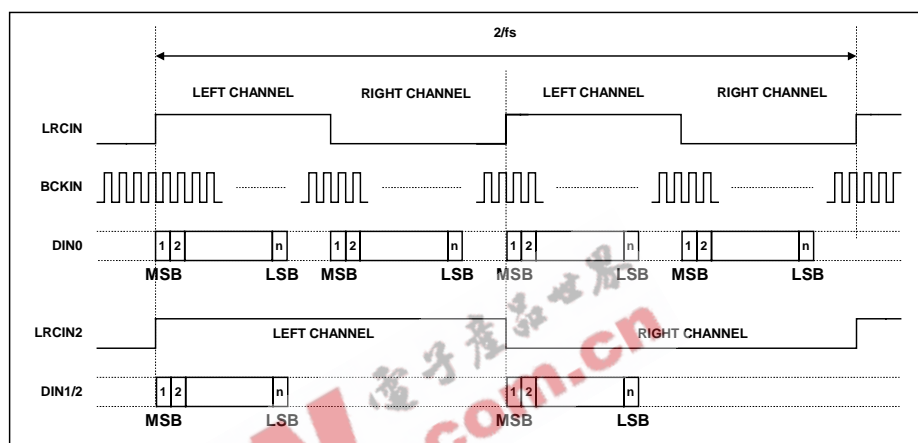

Figure 11 Split Rate Audio Mode Timing Diagram

Notes:

1. Figure 11 shows the timing for left justified. However, this is similar for right justified and I2S.
2. The edges of LRCIN and LRCIN2 **must** be coincidental.

MODES OF OPERATION

Control of the various modes of operation for the WM8756 is either by software control over the serial interface, or by hard-wired pin control. Selection of software or hardware mode is via the MODE pin. The following functions may be controlled either via the serial control interface or by hard wiring of the appropriate pins.

Note : In DSD mode, the control interface is available but none of the functions will have any effect except the PDWN bit because the DSD data by-passes the majority of the signal processing.

FUNCTION		SOFTWARE CONTROL DEFAULT VALUE PIN 11: MODE = 0	HARDWARE CONTROL BEHAVIOUR PIN 11: MODE = 1
	OPTIONS		
Input audio data format	Right justified Left justified I ² S format DSP formats	FMT = 00 (default) FMT = 01 FMT = 10 FMT = 11	Pin 16, 17: ML/I2S, MC/IWL = 00, 01 or 10 Not available in hardware mode Pin 16, 17: ML/I2S, MC/IWL = 11 Not available in hardware mode
Input word length	16 20 24 32	IWL[1:0] = 00 IWL[1:0] = 01 IWL[1:0] = 10 (default) IWL[1:0] = 11	Pin 16, 17: ML/I2S, MC/IWL = 00 (RJ) Pin 16, 17: ML/I2S, MC/IWL = 01 (RJ) Pin 16, 17: ML/I2S, MC/IWL = 10 (RJ) Pin 16, 17: ML/I2S, MC/IWL = 11 (I ² S)
De-emphasis selection	On Off	DEEMPH = 1 DEEMPH = 0 (Default)	Pin 18: MD/DM = 1 Pin 18: MD/DM = 0
Mute	On Off	MUTE = 1 MUTE = 0 (default)	Pin 12: MUTE = 1 Pin 12: MUTE = 0
Input LRCIN polarity	Normal Inverted	LRP = 0 (default) LRP = 1	Not available in hardware mode, default value set
Volume control	Lch, Rch individually Lch, Rch common	ATC = 0; 0dB (default) ATC = 1	Not available in hardware mode, gain defaults to 0dB
Infinite zero detect	On Off	IZD = 1 IZD = 0 (default)	Automute function controlled from MUTE pin low = never mute floating = automute enable high = mute
Power down	Chip on Chip off	PDWN = 0 (default) PDWN = 1	Run SCKI Stop SCKI
DAC output control	See Table 13 for all options	Default is PL[3:0] = 1001, stereo mode	Not available in hardware mode

Table 12 Control Function Summary

SOFTWARE CONTROL MODES

DIGITAL AUDIO INTERFACE CONTROL REGISTERS

Interface format is selected via the FMT[1:0] register bits:

REGISTER ADDRESS	BIT	LABEL	DEFAULT	DESCRIPTION
0000011 Interface Control	1:0	FMT[1:0]	00	Interface format Select 00 : right justified mode 01: left justified mode 10: I2S mode 11: DSP (early or late) mode

In left justified, right justified or I2S modes, the LRP register bit controls the polarity of LRCIN. If this bit is set high, the expected polarity of LRCIN will be the opposite of that shown in Figure 6, Figure 7 and Figure 8. Note that if this feature is used as a means of swapping the left and right channels, a 1 sample phase difference will be introduced.

REGISTER ADDRESS	BIT	LABEL	DEFAULT	DESCRIPTION
0000011 Interface Control	2	LRP	0	LRCIN Polarity 0 : normal LRCIN polarity 1: inverted LRCIN polarity

In DSP modes, the LRCIN register bit is used to select between early and late modes:

REGISTER ADDRESS	BIT	LABEL	DEFAULT	DESCRIPTION
0000011 Interface Control	2	LRP	0	DSP Format 0 : Early DSP mode 1: Late DSP mode

By default, LRCIN and DIN0/1/2 are sampled on the rising edge of BCKIN and should ideally change on the falling edge. Data sources which change LRCIN and DIN0/1/2 on the rising edge of BCKIN can be supported by setting the BCP register bit. Setting BCP to 1 inverts the polarity of BCKIN to the inverse of that shown in Figures 6, 7 and 8.

REGISTER ADDRESS	BIT	LABEL	DEFAULT	DESCRIPTION
0000011 Interface Control	3	BCP	0	BCKIN Polarity 0 : normal BCKIN polarity 1: inverted BCKIN polarity

The IWL[1:0] bits are used to control the input word length.

REGISTER ADDRESS	BIT	LABEL	DEFAULT	DESCRIPTION
0000011 Interface Control	5:4	IWL[1:0]	10	Input Word Length 00 : 16 bit data 01: 20 bit data 10: 24 bit data 11: 32 bit data

Note: If 32-bit mode is selected in right justified mode, the WM8756 defaults to 24 bits.

In all modes, the data is signed 2's complement. The digital filters always input 24-bit data. If the DAC is programmed to receive 16 or 20 bit data, the WM8756 pads the unused LSBs with zeros. If the DAC is programmed into 32 bit mode, the 8 LSBs are ignored.

The REV[2:0] bits are used to invert the phase of the DAC outputs. REV0 controls phase of DAC0, REV1 controls phase of DAC1 and REV2 controls phase of DAC2.

REGISTER ADDRESS	BIT	LABEL	DEFAULT	DESCRIPTION
0000011 Interface Control	8:6	REV[2:0]	000	Output phase direction 1 in bit 6 reverses OUT0L/R. 1 in bit 7 reverses OUT1L/R. 1 in bit 8 reverses OUT2L/R.

MUTE MODES

Setting the MUTE register bit will apply a 'soft' mute to the input of the digital filters:

REGISTER ADDRESS	BIT	LABEL	DEFAULT	DESCRIPTION
0000010 DAC Channel Control	0	MUTE	0	Soft Mute select 0 : Normal Operation 1: Soft mute all channels

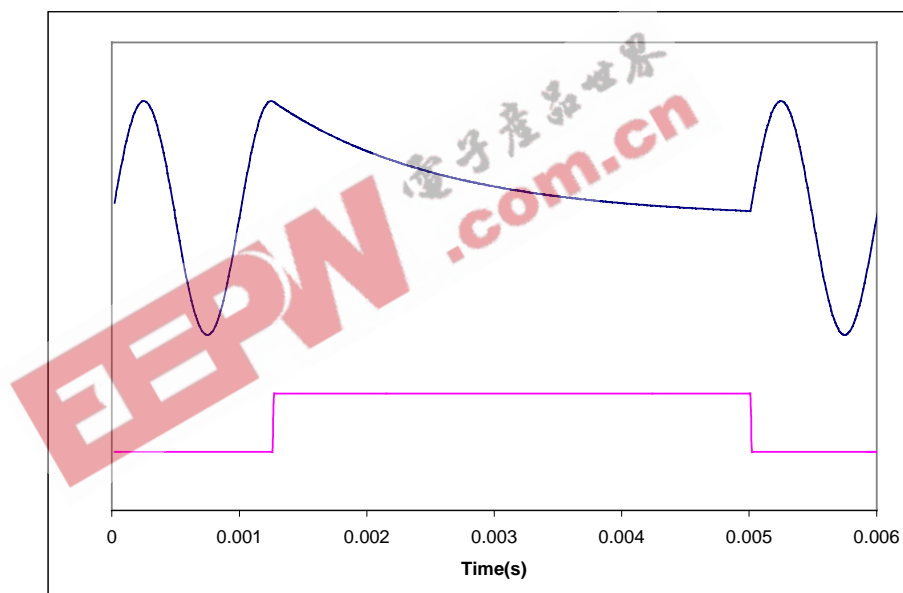

Figure 12 Application and Release of Soft Mute

Figure 12 shows the application and release of MUTE whilst a full amplitude sinusoid is being played at 48kHz sampling rate. When MUTE (lower trace) is asserted, the output (upper trace) begins to decay exponentially from the DC level of the last input sample. The output will decay towards V_{CAP} with a time constant of approximately 64 input samples. If MUTE is applied for 1024 or more input samples, the outputs will be connected directly to V_{CAP} - this feature can be disabled using the IZD (infinite zero detect) bit. When MUTE is de-asserted, the output will restart almost immediately from the current input sample.

Note that all other means of muting the DAC channels (setting the PL[3:0] bits to 0, setting the PDWN bit or setting attenuation to 0) will cause much more abrupt muting of the output.

Setting the IZD register bit will enable the internal analogue mute feature:

REGISTER ADDRESS	BIT	LABEL	DEFAULT	DESCRIPTION
0000010 DAC Channel Control	4	IZD	0	Internal Analogue Mute Disable 0 : Disable Analogue Mute 1: Enable Analogue Mute

With IZD enabled, applying MUTE for 1024 consecutive input samples will cause all outputs to be connected directly to V_{CAP} . Additionally, if 2048 consecutive zero input samples are applied to all 6 channels, and IZD=0, internal analogue mute will be applied. It will be removed as soon as any channel receives a non-zero input.

The MUTE pin can be used as an input. In this case it performs the same function as the MUTE register bit. Driving the MUTE pin high will apply a 'soft' mute. Driving it low again, will remove the MUTE immediately. Note that this hardware mute feature doesn't require the MODE pin to be set high.

MUTE PIN	DESCRIPTION
0	Normal Operation
1	Mute all DAC channels
floating	Enable IZD, Mute becomes an output to indicate when IZD occurs.

A diagram showing how the various Mute modes interact is shown below in Figure 13.

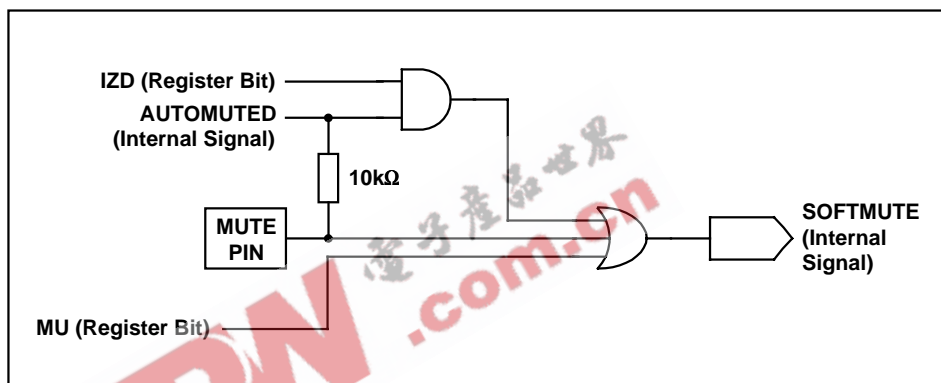

Figure 13 Selection Logic for MUTE Modes

The MUTE pin behaves as a bi-directional function, that is, as an input to select MUTE or NOT-MUTE, or as an output indication of automute operation. MUTE is active high; taking the pin high causes the filters to soft mute, ramping down the audio signal over a few milliseconds. Taking MUTE low again allows data into the filter.

The automute function detects a series of zero value audio samples of 1024 samples long being applied to all 6 channels. After such an event, a latch is set whose output (AUTOMUTED) is wire OR'ed through a 10kohm resistor to the MUTE pin. Thus if the MUTE pin is not being driven, the automute function will assert MUTE.

If MUTE is tied low, AUTOMUTED is overridden and will not mute. If MUTE is driven from a source follower, or diode, then both MUTE and automute functions are available. If MUTE is not driven, AUTOMUTED appears as a weak output (10k source impedance) so can be used to drive external mute circuits. The automute signal is AND'd with IZD, this qualified mute signal then being OR'ed into the SOFTMUTE control. Therefore, in software mode, automute operation may be controlled with IZD control bit.

DE-EMPHASIS MODE

Setting the DEEMPH register bit puts the all the digital filters into de-emphasis mode:

REGISTER ADDRESS	BIT	LABEL	DEFAULT	DESCRIPTION
0000010 DAC Channel Control	1	DEEMPH	0	De-emphasis mode select: 0 : Normal Mode 1: De-emphasis Mode

Refer to Figure 20 - Figure 25 for details of the De-Emphasis filtering effects at different sample rates.

In hardware mode (MODE=1) driving the MD/DM pin high has the same effect as setting the DEEMPH bit:

MODE PIN	MD/DM PIN	DESCRIPTION
0	ignored	De-Emphasis controlled from DEEMPH register bit
1	0	Normal Mode
1	1	De-Emphasis Mode

POWERDOWN MODE

Setting the PDWN register bit immediately connects all outputs to V_{CAP} and selects a low power mode. All trace of the previous input samples is removed, but all control register settings are preserved. When PDWN is cleared again the first 16 input samples will be ignored as the FIR will repeat it's power-on initialisation sequence.

REGISTER ADDRESS	BIT	LABEL	DEFAULT	DESCRIPTION
0000010 DAC Channel Control	2	PDWN	0	Power Down Mode Select: 0 : Normal Mode 1: Power Down Mode

ATTENUATOR CONTROL MODE

Setting the ATC register bit causes the left channel attenuation settings to be applied to both left and right channels for all three pairs of DACs from the next audio input sample. No update to the attenuation registers is required for ATC to take effect.

REGISTER ADDRESS	BIT	LABEL	DEFAULT	DESCRIPTION
0000010 DAC Channel Control	3	ATC	0	Attenuator Control Mode: 0 : Right channels use Right attenuations 1: Right Channels use Left Attenuations

DAC OUTPUT CONTROL

The DAC output control word determines how the left and right inputs to the audio Interface are applied to the left and right DACs:

REGISTER ADDRESS	BIT	LABEL	DEFAULT	DESCRIPTION		
0000010 DAC Control	8:5	PL[3:0]	1001	PL[3:0]	Left Output	Right Output
				0000	Mute	Mute
				0001	Left	Mute
				0010	Right	Mute
				0011	(L+R)/2	Mute
				0100	Mute	Left
				0101	Left	Left
				0110	Right	Left
				0111	(L+R)/2	Left
				1000	Mute	Right
				1001	Left	Right
				1010	Right	Right
				1011	(L+R)/2	Right
				1100	Mute	(L+R)/2
				1101	Left	(L+R)/2
				1110	Right	(L+R)/2
1111	(L+R)/2	(L+R)/2				

Table 13 Input to output control

ATTENUATION CONTROL (ONLY APPLICABLE TO PCM MODE)

Each DAC channel can be attenuated digitally before being applied to the digital filter. Attenuation is 0dB by default but can be set between 0 and 127.5dB in 0.5dB steps using the 7 Attenuation control words. All attenuation registers are double latched allowing new values to be pre-latched to several channels before being updated synchronously. Setting the UPDATE bit on any attenuation write will cause all pre-latched values to be immediately applied to the DAC channels. A master attenuation register is also included, allowing all attenuations to be set to the same value in a single write.

REGISTER ADDRESS	BIT	LABEL	DEFAULT	DESCRIPTION
0000 Attenuation DACLO	7:0	L0A[7:0]	11111111 (0dB)	Attenuation level of left channel DACLO in 0.5dB steps, see Table 15 Attenuation Control Levels.
	8	UPDATE	Not latched	Controls simultaneous update of all Attenuation Latches 0: Store DACLO in intermediate latch (no change to output) 1: Store DACLO and update attenuation on all channels.
0001 Attenuation DACR0	7:0	R0A[7:0]	11111111 (0dB)	Attenuation level of right channel DACR0 in 0.5dB steps, see Table 15 Attenuation Control Levels.
	8	UPDATE	Not latched	Controls simultaneous update of all Attenuation Latches 0: Store DACR0 in intermediate latch (no change to output) 1: Store DACR0 and update attenuation on all channels.
0100 Attenuation DACL1	7:0	L1A[7:0]	11111111 (0dB)	Attenuation level of left channel DACL1 in 0.5dB steps, see Table 15 Attenuation Control Levels.
	8	UPDATE	Not latched	Controls simultaneous update of all Attenuation Latches 0: Store DACL1 in intermediate latch (no change to output) 1: Store DACL1 and update attenuation on all channels.
0101 Attenuation DACR1	7:0	R1A[7:0]	11111111 (0dB)	Attenuation level of right channel DACR1 in 0.5dB steps, see Table 15 Attenuation Control Levels.
	8	UPDATE	Not latched	Controls simultaneous update of all Attenuation Latches 0: Store DACR1 in intermediate latch (no change to output) 1: Store DACR1 and update attenuation on all channels.
0110 Attenuation DACL2	7:0	L2A[7:0]	11111111 (0dB)	Attenuation level of left channel DACL2 in 0.5dB steps, see Table 15 Attenuation Control Levels.
	8	UPDATE	Not latched	Controls simultaneous update of all Attenuation Latches 0: Store DACL2 in intermediate latch (no change to output) 1: Store DACL2 and update attenuation on all channels.
0111 Attenuation DACR2	7:0	R2A[7:0]	11111111 (0dB)	Attenuation level of right channel DACR2 in 0.5dB steps, see Table 15 Attenuation Control Levels.
	8	UPDATE	Not latched	Controls simultaneous update of all Attenuation Latches 0: Store DACR2 in intermediate latch (no change to output) 1: Store DACR2 and update attenuation on all channels.
1000 Master Attenuation (all channels)	7:0	MASTA[7:0]	11111111 (0dB)	Attenuation of all channels in 0.5dB steps, see Table 15 Attenuation Control Levels.
	8	UPDATE	Not latched	Controls simultaneous update of all Attenuation Latches 0: Store MASTA[7:0] in all intermediate latches (no change) 1: Store MASTA[7:0] and update attenuation on all channels.

Table 14 Attenuation Register Map**Notes:**

- The UPDATE bit is not latched. If UPDATE=0, the Attenuation value will be written to the pre-latch but not applied to the relevant DAC. If UPDATE=1, all pre-latched values will be applied from the next input sample. Writing to MASTA[7:0] overwrites any values previously sent to L0A[7:0], L1A[7:0], L2A[7:0], R0A[7:0], R1A[7:0], R2A[7:0].
- The attenuation level is only applied when the input data passes through midrail unless the ZCD function (register 9, bit 1) is disabled where it will change immediately.

DAC OUTPUT ATTENUATION

Register bits [7:0] of L0A and R0A control the left and right channel attenuation of DAC 0. Register bits [7:0] of L1A and R1A control the left and right channel attenuation of DAC 1. Register bits [7:0] of L2A and R2A control the left and right channel attenuation of DAC 2. Register bits [7:0] of MASTA are a register that can be used to control attenuation of all channels.

Table 15 shows how the attenuation levels are selected from the 8-bit words.

AX[7:0]	ATTENUATION LEVEL
00(hex)	-∞dB (mute)
01(hex)	-127.5dB
:	:
:	:
:	:
FE(hex)	-0.5dB
FF(hex)	0dB

Table 15 Attenuation Control Levels

EXTENDED INTERFACE CONTROL

It is possible to run the WM8756 channels at different rates with the front two channels running at twice the rate of the rear four channels. In this mode which is enabled by bit 0 of register 9, the interface runs at the faster data rate but pin 13 acts as the framing LRCIN for the rear channels see Figure 11.

REGISTER ADDRESS	BIT	LABEL	DEFAULT	DESCRIPTION
0001001 Split rate mode	0	2SPD	0	Activates the split rate mode 0: Normal operation. 1: Split rate operation.

When the WM8756 receives updates to the volume levels it will, by default, wait for the signal to pass through midrail before applying the change to the output. This ensures that minimal distortion is seen on the output when the volume is changed. This function applies individually to each channel.

REGISTER ADDRESS	BIT	LABEL	DEFAULT	DESCRIPTION
0001001 Zero crossing detect	1	ZCD	0	Controls the ZCD 0: Enabled. 1: Disabled.

HARDWARE CONTROL MODES

When the MODE pin is held high, and DSDB pin is high, the following hardware modes of operation are available.

MUTE AND AUTOMUTE OPERATION

In both hardware and software modes pin 12 (MUTE) controls selection of MUTE directly, and can be used to enable and disable the automute function, or as an output of the automuted signal.

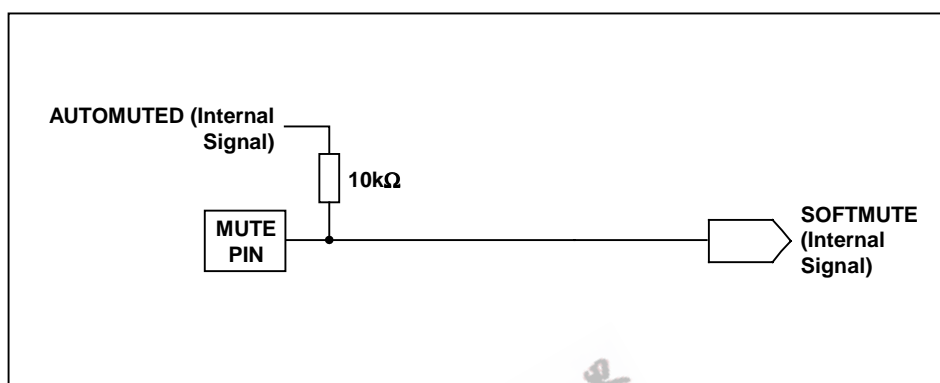

Figure 14 Mute Circuit Operation

The MUTE pin behaves as a bi-directional function, that is, as an input to select MUTE or NOT-MUTE, or as an output indication of automute operation. MUTE is active high; taking the pin high causes the filters to soft mute, ramping down the audio signal over a few milliseconds. Taking MUTE low again allows data into the filter.

The automute function detects a series of zero value audio samples of 1024 samples long being applied to all 6 channels. After such an event, a latch is set whose output (AUTOMUTED) is wire OR'ed through a 10kohm resistor to the MUTE pin. Thus if the MUTE pin is not being driven, the automute function will assert MUTE.

If MUTE is tied low, AUTOMUTED is overridden and will not mute. If MUTE is driven from a source follower, or diode, then both MUTE and automute functions are available. If MUTE is not driven, AUTOMUTED appears as a weak output (10k source impedance) so can be used to drive external mute circuits.

INPUT FORMAT SELECTION

In hardware mode, pins 16 and 17 become input controls for selection of input data format type and input data word length (see Table 16). I²S mode is designed to support any word length provided enough bit clocks are sent.

ML/I2S	MC/IWL	INPUT DATA MODE
0	0	16-bit right justified
0	1	20-bit right justified
1	0	24-bit right justified
1	1	I ² S mode

Table 16 Control of Input Data Format Type and Input Data Word Length

MD/DM DE-EMPHASIS

In hardware mode, pin 18 becomes an input control for selection of de-emphasis filtering to be applied (see Table 17).

MD/DM	DE-EMPHASIS MODE
0	De-emphasis off
1	De-emphasis on

Table 17 De-emphasis Control

DSDB MODE SELECT

This pin puts the device into DSD mode when taken low. Due to the nature of DSD operation only a single software controlled function is available in this mode. This is the PDWN bit.

DSDB	DSD MODE
0	Device in DSD mode
1	Device in normal PCM operation

Table 18 DSD mode Control

DSD DIGITAL AUDIO INTERFACE

DSD mode is selected by taking the DSDB pin low. In this mode the internal digital filters are by-passed, and the already modulated bitstream data is applied directly to the Switched Capacitor DAC filter where it is converted and low-pass filtered.

Two formats are supported for data transfer, NORMAL or PHASE MODULATED.

In Normal mode, DSD data is simply clocked into the device using the rising edge of the 64fs DSDCLK64 signal (see Figure 3).

In Phase Modulation mode, the data is supplied in Manchester encoded form (a bit transition occurs during every data bit, which shapes the spectral energy minimising corruption of the analogue outputs). A secondary clock DSDCLK128, at 128fs is used to simplify data recovery, the data simply being clocked with the falling edge of DSDCLK128 when DSDCLK64 is low (see Figure 4). Operation of PHASE MODULATED mode is auto-detected by the presence of a clock signal on the DSDCLK128 pin.

DSD clocks are either inputs (when DMSLV = '0') or outputs (when DMSLV = '1'). When DMSLV is '1' the clocks are derived by using the SCKI as detailed below:

DMCKSEL	DSDCLK64	DSDCLK128
0	SCKI/4	SCKI/2
1	SCKI/6	SCKI/3

Table 19 Master/Slave clock selection

DMSLV	CLOCKS
0	inputs
1	outputs

Table 20 Master/Slave function

See Figure 3 and Figure 4 for details of DSD interface timing

SOFTWARE CONTROL INTERFACE

The software control interface uses a 3-wire serial control interface. Selection of interface format is achieved by setting the state of the MODE pin.

MODE	INTERFACE FORMAT
0	Software Control Mode
1	Hardware Control Mode

Table 21 Control Interface Mode Selection

3-WIRE (SPI COMPATIBLE) SERIAL CONTROL MODE

The WM8756 can be controlled using a 3-wire serial interface. MD/DM is used for the program data, MC/IWL is used to clock in the program data and ML/I2S is used to latch in the program data. The 3-wire interface protocol is shown in Figure 15.

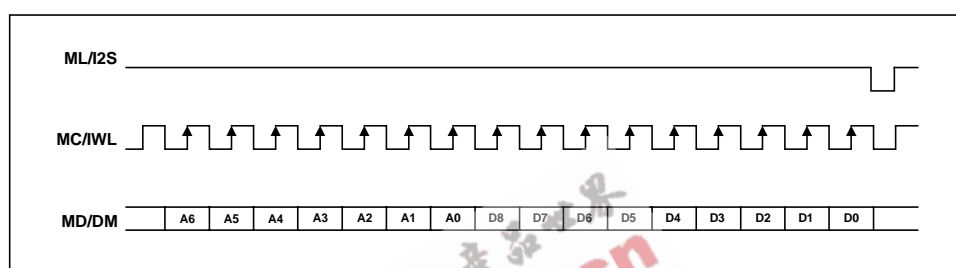

Figure 15 3-wire Serial Interface

Notes:

1. A[6:0] are Control Address Bits
2. D[8:0] are Control Data Bits

REGISTER MAP

There are 9 registers with 9 bits per register. These can be controlled using the Control Interface. Table 22 below gives an overview of all the WM8756 control registers. Details of each register's function are summarised on the following pages (Table 23).

	A6	A5	A4	A3	A2	A1	A0	D8	D7	D6	D5	D4	D3	D2	D1	D0
M0	0	0	0	0	0	0	0	UPDATE	L0A7	L0A 6	L0A 5	L0A 4	L0A 3	L0A 2	L0A 1	L0A 0
M1	0	0	0	0	0	0	1	UPDATE	R0A7	R0A 6	R0A 5	R0A 4	R0A 3	R0A 2	R0A 1	R0A 0
M2	0	0	0	0	0	1	0	PL3	PL2	PL1	PL0	IZD	ATC	PDWN	DEEMPH	MUTE
M3	0	0	0	0	0	1	1	REV2	REV1	REV0	IWL1	IWL0	BCP	LRP	FMT1	FMT0
M4	0	0	0	0	1	0	0	UPDATE	L1A7	L1A 6	L1A 5	L1A 4	L1A 3	L1A 2	L1A 1	L1A 0
M5	0	0	0	0	1	0	1	UPDATE	R1A7	R1A 6	R1A 5	R1A 4	R1A 3	R1A 2	R1A 1	R1A 0
M6	0	0	0	0	1	1	0	UPDATE	L2A7	L2A 6	L2A 5	L2A 4	L2A 3	L2A 2	L2A 1	L2A 0
M7	0	0	0	0	1	1	1	UPDATE	R2A7	R2A 6	R2A 5	R2A 4	R2A 3	R2A 2	R2A 1	R2A 0
M8	0	0	0	1	0	0	0	UPDATE	MASTA7	MASTA 6	MASTA 5	MASTA 4	MASTA 3	MASTA 2	MASTA 1	MASTA 0
M9	0	0	0	1	0	0	1	0	0	0	0	0	0	0	ZCD	2SPD

Table 22 Register Map

 电子產品世界
 .com.cn

REGISTER ADDRESS	BIT	LABEL	DEFAULT	DESCRIPTION					
0000000 Attenuation DACL0	7:0	L0A[7:0]	11111111 (0dB)	Attenuation level of left channel DACL0 in 0.5dB steps, see Table 15 Attenuation Control Levels.					
	8	UPDATE	Not latched	Controls simultaneous update of all Attenuation Latches 0: Store DACL0 in intermediate latch (no change to output) 1: Store DACL0 and update attenuation on all channels.					
0000001 Attenuation DACR0	7:0	R0A[7:0]	11111111 (0dB)	Attenuation level of right channel DACR0 in 0.5dB steps, see Table 15 Attenuation Control Levels.					
	8	UPDATE	Not latched	Controls simultaneous update of all Attenuation Latches 0: Store DACR0 in intermediate latch (no change to output) 1: Store DACR0 and update attenuation on all channels.					
0000010 DAC Control	0	MUTE	0	Left and Right DACs soft mute control 0: No Mute 1: Mute					
	1	DEEMPH	0	De-emphasis Control 0: Normal Response (see Figure 16 - Figure 19) 1: De-emphasis Response (see Figure 20 - Figure 25)					
	2	PDWN	0	Left and Right DACs Power-down Control 0: All DACs running, output is active 1: All DACs in power saving mode, output muted					
	3	ATC	0	Attenuator Control 0: All DACs use attenuations as programmed. 1: Right chan. DACs use corresponding left DAC attenuations					
	4	IZD	0	Infinite zero detection circuit control and automute control 0: Infinite zero detect disabled 1: Infinite zero detect enabled					
	8:5	PL[3:0]	1001	DAC Output Control					
				PL[3:0]	Left Output	Right Output	PL[3:0]	Left Output	Right Output
				0000	Mute	Mute	1000	Mute	Right
			0001	Left	Mute	1001	Left	Right	
			0010	Right	Mute	1010	Right	Right	
			0011	(L+R)/2	Mute	1011	(L+R)/2	Right	
			0100	Mute	Left	1100	Mute	(L+R)/2	
			0101	Left	Left	1101	Left	(L+R)/2	
			0110	Right	Left	1110	Right	(L+R)/2	
			0111	(L+R)/2	Left	1111	(L+R)/2	(L+R)/2	

0000011 Interface Control	1:0	FMT[1:0]	00	Interface format select 00: right justified mode 01: left justified mode 10: I2S mode 11: DSP mode
	2	LRP	0	LRCIN Polarity or LRCIN Phase
				Left Justified / Right Justified / I2S 0: Standard LRCIN Polarity 1: Inverted LRCIN Polarity
	3	BCP	0	BCKIN Polarity 0: Normal (DIN[2:0] and LRCIN sampled on rising edge) 1: Inverted (DIN[2:0] and LRCIN sampled on falling edge)
	5:4	IWL[1:0]	0	Input Word Length 00: 16-bit Mode 01: 20-bit Mode 10: 24-bit Mode 11: 32-bit Mode (not supported in right justified mode)
8:6	REV[2:0]	000	Controls the output phase of the three stereo channels 1 in bit 6 reverses the phase of data output on OUT0L/R. 1 in bit 7 reverses the phase of data output on OUT1L/R. 1 in bit 8 reverses the phase of data output on OUT2L/R.	
0000100 Attenuation DACL1	7:0	L1A[7:0]	11111111 (0dB)	Attenuation level of left channel DACL1 in 0.5dB steps, see Table 15 Attenuation Control Levels.
	8	UPDATE	Not latched	Controls simultaneous update of all Attenuation Latches 0: Store DACL1 in intermediate latch (no change to output) 1: Store DACL1 and update attenuation on all channels.
0000101 Attenuation DACR1	7:0	R1A[7:0]	11111111 (0dB)	Attenuation level of right channel DACR1 in 0.5dB steps, see Table 15 Attenuation Control Levels.
	8	UPDATE	Not latched	Controls simultaneous update of all Attenuation Latches 0: Store DACR1 in intermediate latch (no change to output) 1: Store DACR1 and update attenuation on all channels.
0000110 Attenuation DACL2	7:0	L2A[7:0]	11111111 (0dB)	Attenuation level of left channel DACL2 in 0.5dB steps, see Table 15 Attenuation Control Levels.
	8	UPDATE	Not latched	Controls simultaneous update of all Attenuation Latches 0: Store DACL2 in intermediate latch (no change to output) 1: Store DACL2 and update attenuation on all channels.
0000111 Attenuation DACR2	7:0	R2A[7:0]	11111111 (0dB)	Attenuation level of right channel DACR2 in 0.5dB steps, see Table 15 Attenuation Control Levels.
	8	UPDATE	Not latched	Controls simultaneous update of all Attenuation Latches 0: Store DACR2 in intermediate latch (no change to output) 1: Store DACR2 and update attenuation on all channels.
0001000 Master Attenuation (all channels)	7:0	MASTA[7:0]	11111111 (0dB)	Attenuation level of all channels in 0.5dB steps. See Table 15 Attenuation Control Levels
	8	UPDATE	Not latched	Controls simultaneous update of all Attenuation Latches 0: Store MASTA[7:0] in all intermediate latches (no change to output) 1: Store MASTA[7:0] and update attenuation on all channels.

REGISTER ADDRESS	BIT	LABEL	DEFAULT	DESCRIPTION
0001001 Extended interface control	0	2SPD	0	Activates the split rate mode where the front channels run at 192kHz and the rear four channels run at 96kHz. 0: Normal operation. 1: Split rate operation.
	1	ZCD	0	Controls the operation of the zero crossing detect mechanism which ensures that the volume is only updated on each channel when the signal passes through midrail. 0: Enable zero detect. 1: Disable zero detect.

Table 23 Register Map Description

EEPW.com.cn 电子产品世界

DAC FILTER RESPONSES

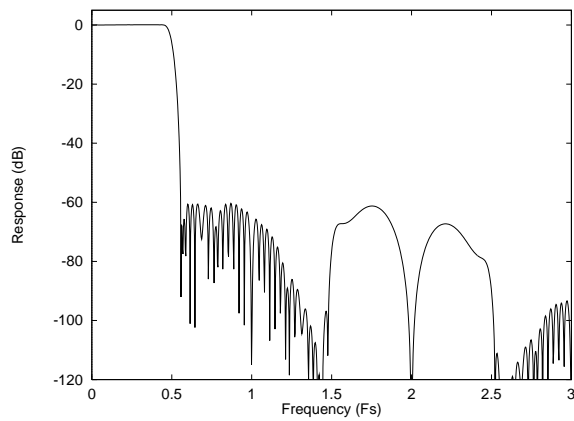

Figure 16 DAC Digital Filter Frequency Response – 44.1, 48 and 96KHz

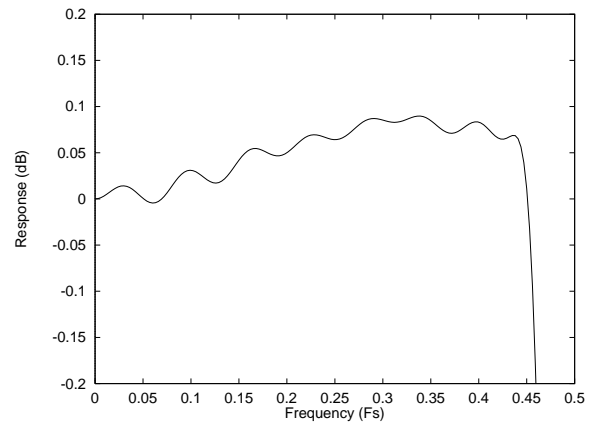

Figure 17 DAC Digital Filter Ripple –44.1, 48 and 96kHz

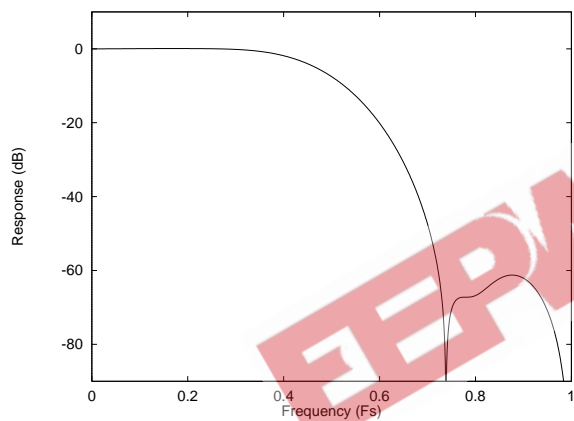

Figure 18 DAC Digital Filter Frequency Response 192kHz

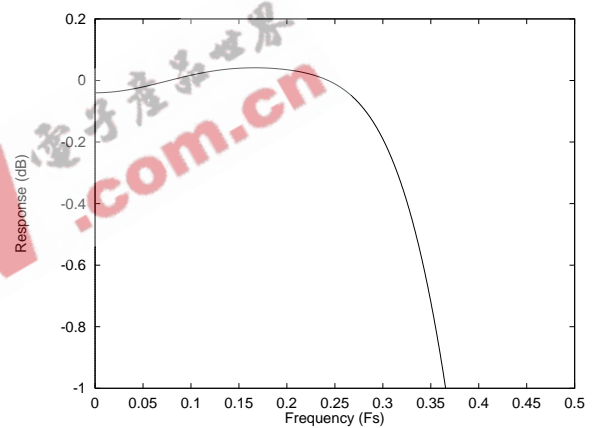

Figure 19 DAC Digital filter Ripple 192kHz

DIGITAL DE-EMPHASIS CHARACTERISTICS

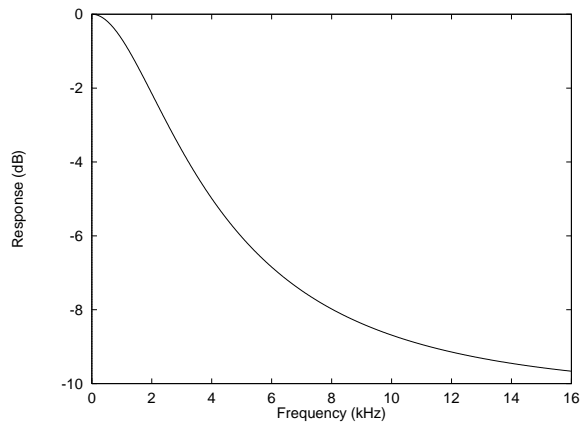

Figure 20 De-Emphasis Frequency Response (32kHz)

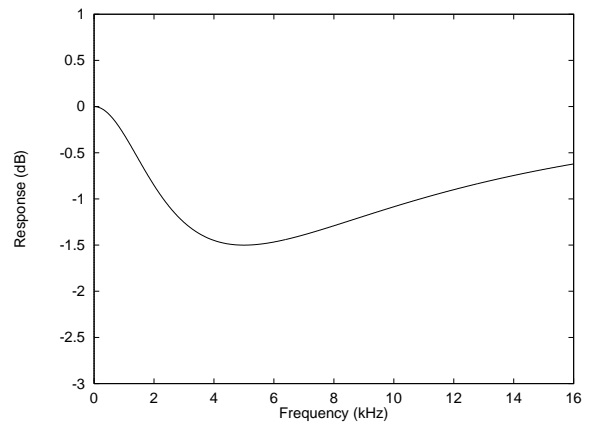

Figure 21 De-Emphasis Error (32kHz)

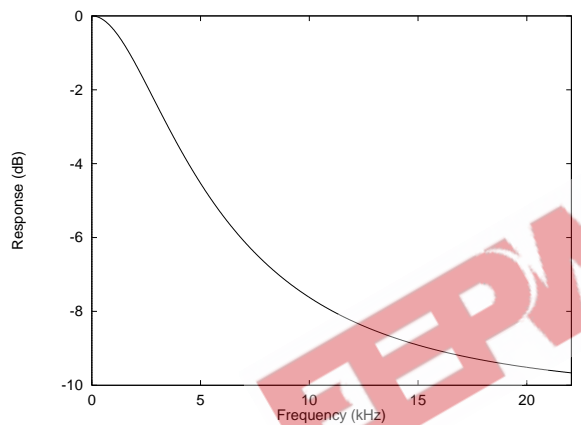

Figure 22 De-Emphasis Frequency Response (44.1kHz)

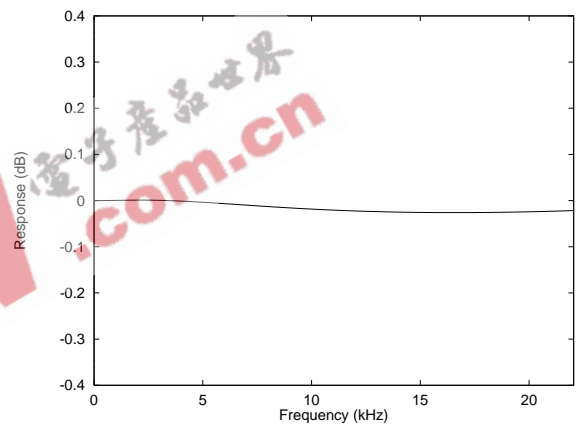

Figure 23 De-Emphasis Error (44.1kHz)

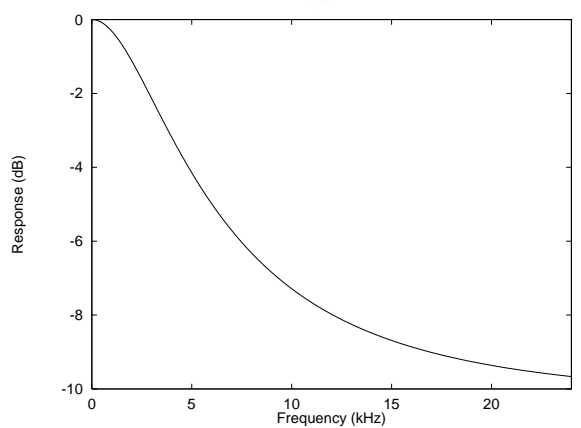

Figure 24 De-Emphasis Frequency Response (48kHz)

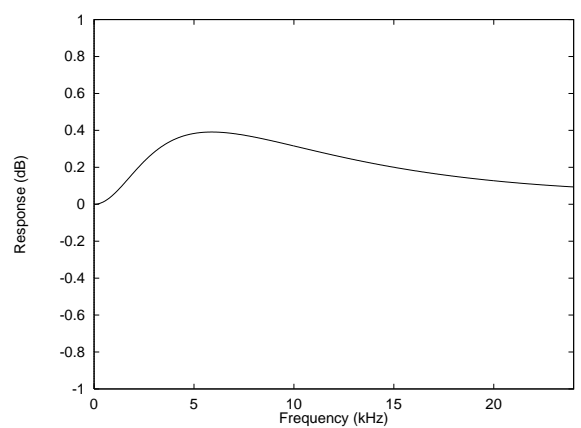

Figure 25 De-Emphasis Error (48kHz)

DSD MODE CHARACTERISTICS

The following filter responses show the DAC output frequency response in SACD or DSD mode, with and without an external 3rd order Lowpass filter. Table 15 gives details of the attenuation versus frequency of the two cases.

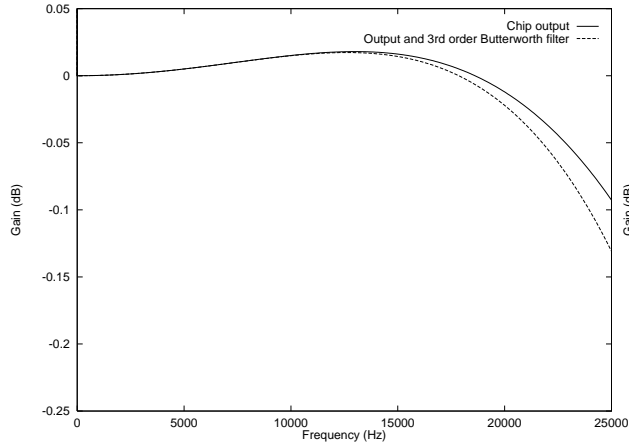

Figure 26 DSD Mode Frequency Response – to 25kHz

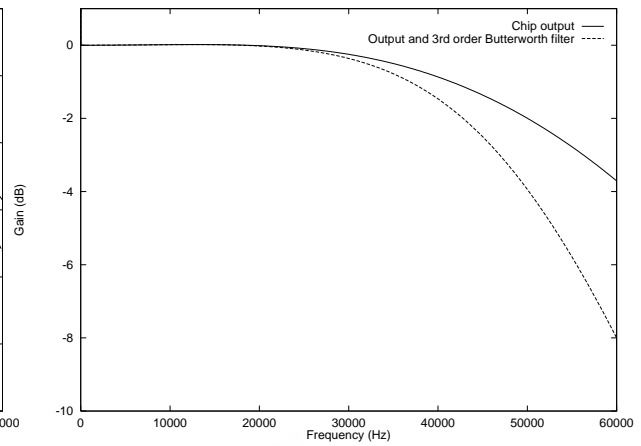

Figure 27 DSD Mode Frequency Response – to 60kHz

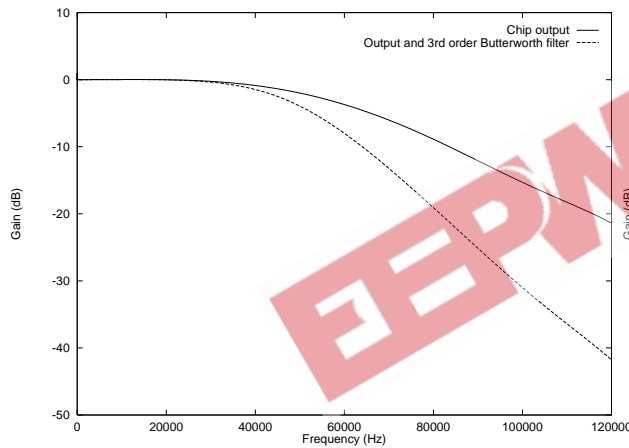

Figure 28 DSD Mode Frequency Response - to 120kHz

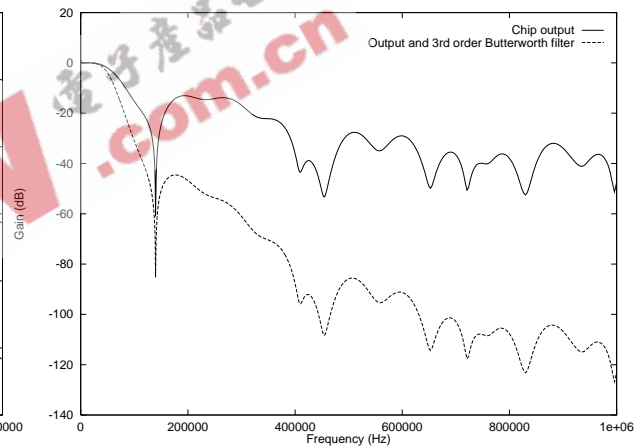

Figure 29 DSD Mode Frequency Response – to 1MHz

RECOMMENDED EXTERNAL COMPONENTS

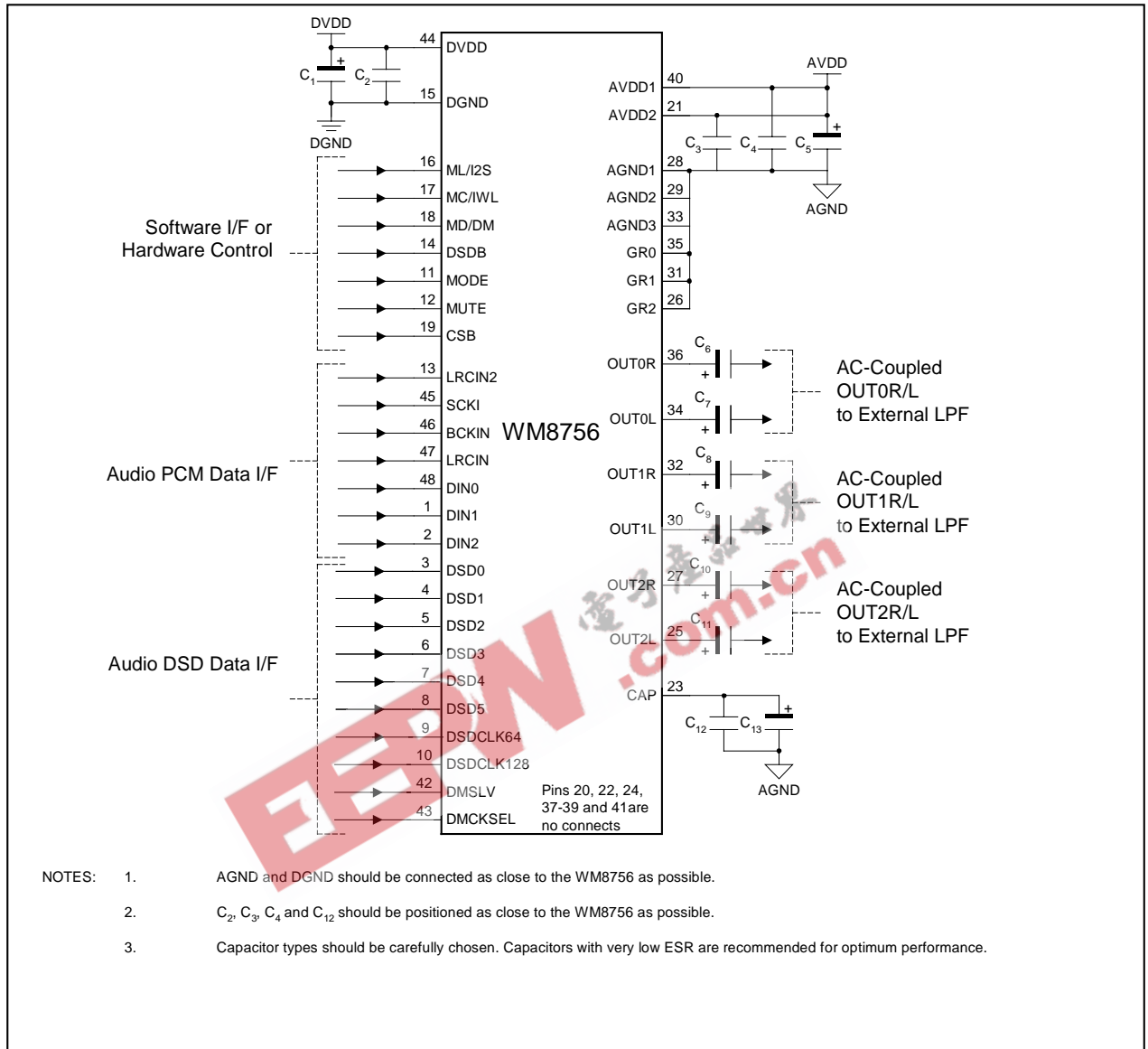

Figure 30 External Components Diagram

RECOMMENDED EXTERNAL COMPONENTS VALUES

COMPONENT REFERENCE	SUGGESTED VALUE	DESCRIPTION
C1 and C5	10µF	De-coupling for DVDD and AVDD.
C2 to C4	0.1µF	De-coupling for DVDD and AVDD.
C6 to C11	10µF	Output AC coupling caps to remove midrail DC level from outputs.
C12	0.1µF	Reference de-coupling capacitors for CAP pin.
C13	10µF	

Table 24 External Components Description

SUGGESTED ANALOGUE LOW PASS POST DAC FILTERS

For PCM operation, the low out of band noise from the WM8756 means that a low order post DAC filter can be used such as 2nd order Salen and Key type.

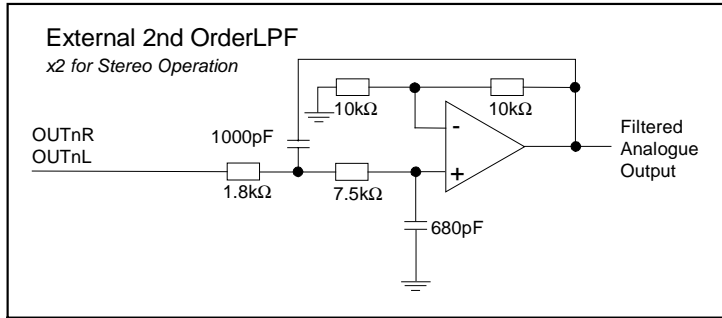

Figure 31 Second order active RC low pass filter

For SACD operation a 3rd order filter may be used to meet Scarlet book standards (-3dB point at maximum 50kHz, minimum 30dB attenuation at 100kHz) when combined with the filter response of the internal FIR filter. Such a filter may be built using a single opamp in similar fashion to the second order filter above, so costing little extra to implement. The same filter may also be used very satisfactorily for PCM operation.

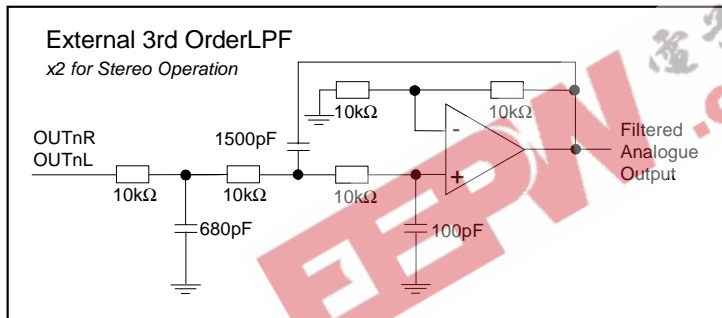

Figure 32 Third order active RC low pass filter

RECOMMENDED APPLICATIONS

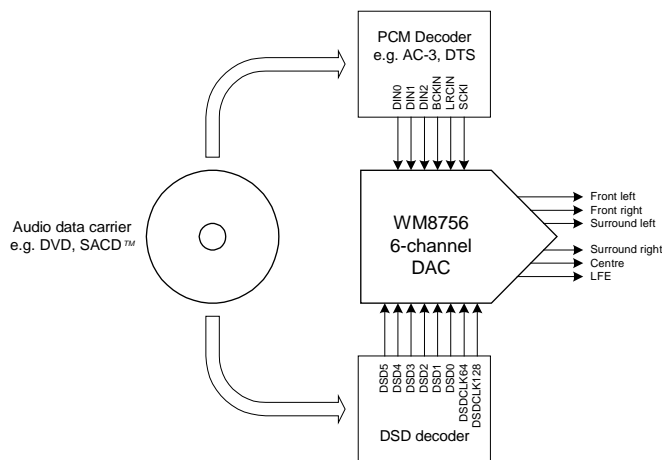

Figure 33 Combined PCM and DSD Circuit Configuration

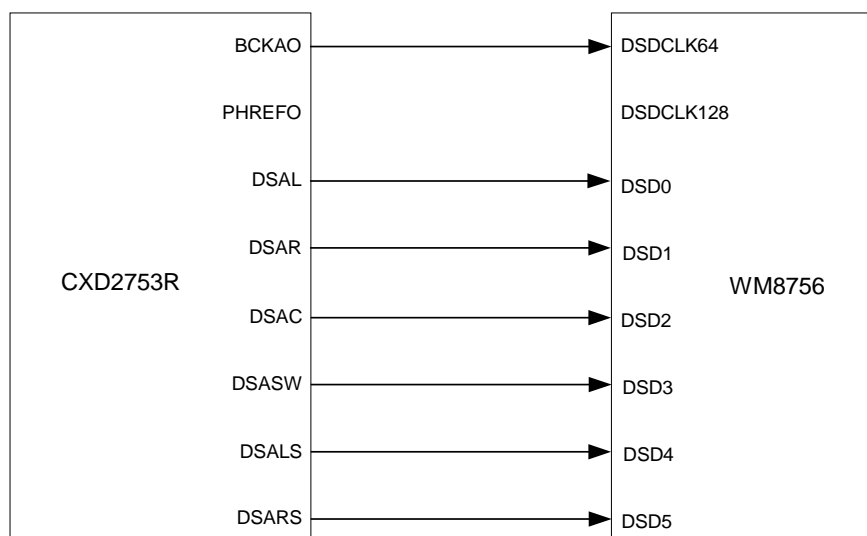
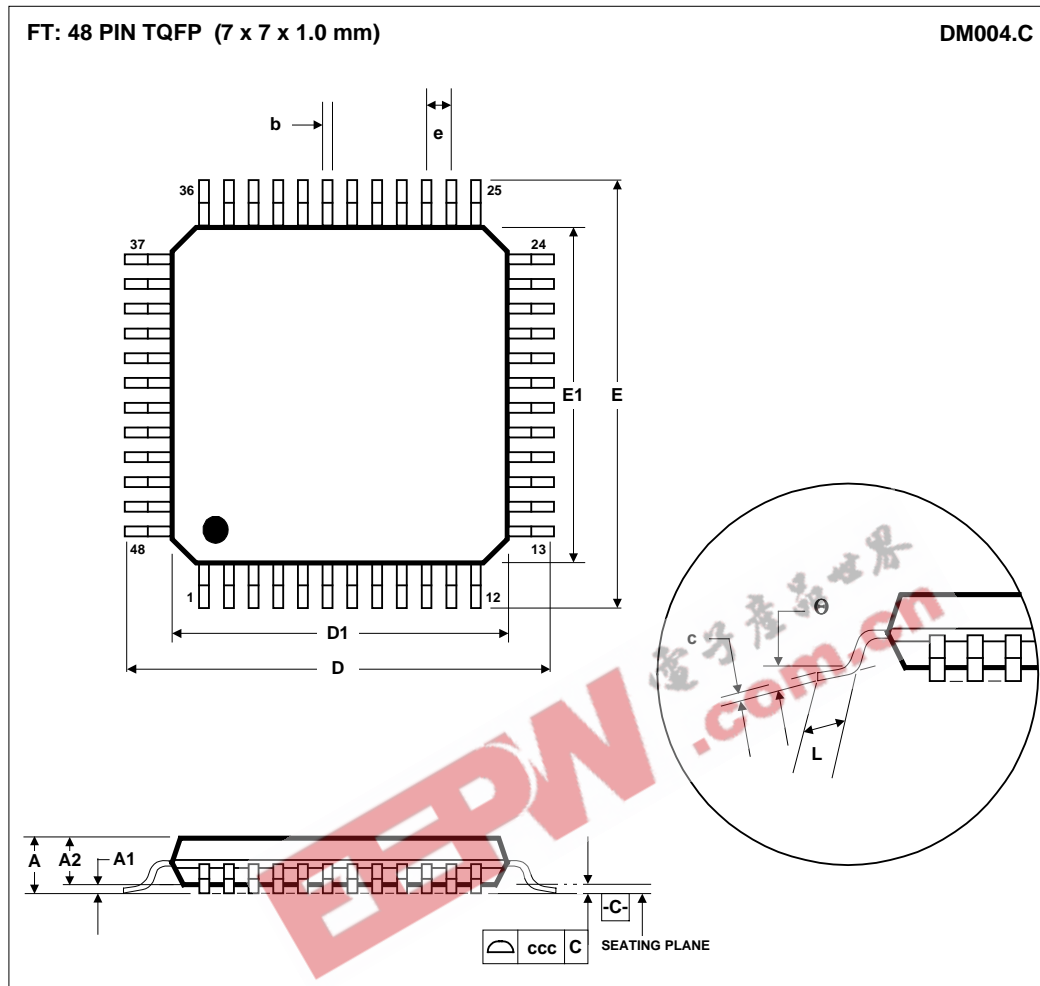

Figure 34 Connection of WM8756 as Slave to Sony 6-CH DSD Decoder Chip in Normal mode

To use the WM8756 with the Sony CXD2753R there are several configuration options:

1. In DSD mode if the WM8756 is being run in NORMAL mode as a SLAVE device the only clock input which the WM8756 requires is DSDCLK64, this should be connected to the BCKAO pin of the CXD2753R. In this BCKAO should be a falling edge set as illustrated on page 20 of the CXD2753R datasheet (Rev PE01704-PS).
 2. In DSD mode if the WM8756 is being run in PHASE MODULATION mode as a SLAVE device the clock inputs which the WM8756 requires are DSDCLK64 and DSDCLK128. DSDCLK64 and DSDCLK128 should be connected to PHREFO and BCKAO respectively on the CXD2753R. In Phase Modulation mode phase 2 should be selected for the PHREFO clock and BCKAO should be a rising edge set, as illustrated on page 20 of the CXD2753R datasheet (Rev PE01704-PS).
- To run the WM8756 in DSD mode but as a MASTER SCLK must be present on the device.
 - If the device is intended to be used for both PCM and DSD data in either MASTER or SLAVE mode SCLK can be present on the WM8756 at all times as this pin is ignored by the WM8756 when it is not required.

PACKAGE DIMENSIONS



Symbols	Dimensions (mm)		
	MIN	NOM	MAX
A	-----	-----	1.20
A ₁	0.05	-----	0.15
A ₂	0.95	1.00	1.05
b	0.17	0.22	0.27
c	0.09	-----	0.20
D	9.00 BSC		
D ₁	7.00 BSC		
E	9.00 BSC		
E ₁	7.00 BSC		
e	0.50 BSC		
L	0.45	0.60	0.75
θ	0°	3.5°	7°
Tolerances of Form and Position			
ccc	0.08		
REF:	JEDEC.95, MS-026		

NOTES:

- A. ALL LINEAR DIMENSIONS ARE IN MILLIMETERS.
 B. THIS DRAWING IS SUBJECT TO CHANGE WITHOUT NOTICE.
 C. BODY DIMENSIONS DO NOT INCLUDE MOLD FLASH OR PROTRUSION, NOT TO EXCEED 0.25MM.
 D. MEETS JEDEC.95 MS-026, VARIATION = ABC. REFER TO THIS SPECIFICATION FOR FURTHER DETAILS.

IMPORTANT NOTICE

Wolfson Microelectronics Ltd (WM) reserve the right to make changes to their products or to discontinue any product or service without notice, and advise customers to obtain the latest version of relevant information to verify, before placing orders, that information being relied on is current. All products are sold subject to the WM terms and conditions of sale supplied at the time of order acknowledgement, including those pertaining to warranty, patent infringement, and limitation of liability.

WM warrants performance of its products to the specifications applicable at the time of sale in accordance with WM's standard warranty. Testing and other quality control techniques are utilised to the extent WM deems necessary to support this warranty. Specific testing of all parameters of each device is not necessarily performed, except those mandated by government requirements.

In order to minimise risks associated with customer applications, adequate design and operating safeguards must be used by the customer to minimise inherent or procedural hazards.

WM assumes no liability for applications assistance or customer product design. WM does not warrant or represent that any license, either express or implied, is granted under any patent right, copyright, mask work right, or other intellectual property right of WM covering or relating to any combination, machine, or process in which such products or services might be or are used. WM's publication of information regarding any third party's products or services does not constitute WM's approval, license, warranty or endorsement thereof.

Reproduction of information from the WM web site or datasheets is permissible only if reproduction is without alteration and is accompanied by all associated warranties, conditions, limitations and notices. Representation or reproduction of this information with alteration voids all warranties provided for an associated WM product or service, is an unfair and deceptive business practice, and WM is not responsible nor liable for any such use.

Resale of WM's products or services with statements different from or beyond the parameters stated by WM for that product or service voids all express and any implied warranties for the associated WM product or service, is an unfair and deceptive business practice, and WM is not responsible nor liable for any such use.

ADDRESS:

Wolfson Microelectronics Ltd
20 Bernard Terrace
Edinburgh
EH8 9NX
United Kingdom

Tel :: +44 (0)131 667 9386

Fax :: +44 (0)131 667 5176

Email :: sales@wolfsonmicro.com