



### 512Kx8 MONOLITHIC FLASH, SMD 5962-96692

#### FEATURES

- Access Times of 60, 70, 90, 120, 150ns
- Packaging
  - 32 pin, Hermetic Ceramic, 0.600" DIP (Package 300)
  - 32 lead, Hermetic Ceramic, 0.400" SOJ (Package 101)
  - 32 pin, Rectangular Ceramic Leadless Chip Carrier (Package 601)
  - 32 lead Flatpack (Package 220)
- 1,000,000 Erase/Program Cycles Minimum
- Sector Erase Architecture
  - 8 equal size sectors of 64K bytes each
  - Any combination of sectors can be concurrently erased. Also supports full chip erase
- Organized as 512Kx8
- Commercial, Industrial and Military Temperature Ranges
- 5 Volt Programming. 5V ± 10% Supply.
- Low Power CMOS
- Embedded Erase and Program Algorithms
- TTL Compatible Inputs and CMOS Outputs
- Page Program Operation and Internal Program Control Time.

Note: For programming information refer to Flash Programming 4M5 Application Note.

This product is subject to change without notice.

#### Pin Configuration For WMF512K8-XXX5

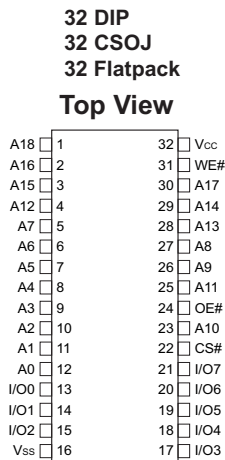

#### Pin Configuration For WMF512K8-XCLX5

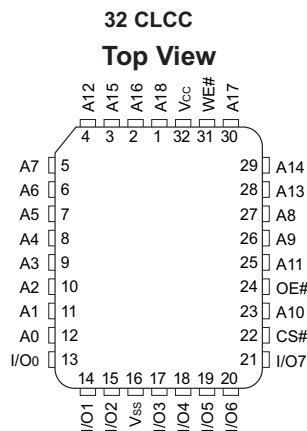

#### Pin Description

A0-18	Address Inputs
I/O0-7	Data Input/Output
CS#	Chip Select
OE#	Output Enable
WE#	Write Enable
Vcc	+5.0V Power
Vss	Ground



**ABSOLUTE MAXIMUM RATINGS (1)**

Parameter		Unit
Operating Temperature	-55 to +125	°C
Supply Voltage (V <sub>CC</sub> ) (1)	-2.0 to +7.0	V
Signal Voltage Range(any pin except A9) (2)	-2.0 to +7.0	V
Storage Temperature Range	-65 to +150	°C
Lead Temperature (soldering, 10 seconds)	+300	°C
Data Retention Mil Temp	20	years
Endurance - erase/program cycles (Mil Temp)	100,000 min	cycles
A9 Voltage for sector protect (V <sub>ID</sub> ) (3)	-2.0 to +14.0	V

**RECOMMENDED OPERATING CONDITIONS**

Parameter	Symbol	Min	Max	Unit
Supply Voltage	V <sub>CC</sub>	4.5	5.5	V
Input High Voltage	V <sub>IH</sub>	2.0	V <sub>CC</sub> + 0.5	V
Input Low Voltage	V <sub>IL</sub>	-0.5	+0.8	V
Operating Temp. (Mil.)	T <sub>A</sub>	-55	+125	°C
Operating Temp. (Ind.)	T <sub>A</sub>	-40	+85	°C
A9 Voltage for Sector Protect	V <sub>ID</sub>	11.5	12.5	V

NOTES:

- Stresses above the absolute maximum rating may cause permanent damage to the device. Extended operation at the maximum levels may degrade performance and affect reliability.
- Minimum DC voltage on input or I/O pins is -0.5V. During voltage transitions, inputs may overshoot V<sub>SS</sub> to -2.0 V for periods of up to 20ns. Maximum DC voltage on output and I/O pins is V<sub>CC</sub> + 0.5V. During voltage transitions, outputs may overshoot to V<sub>CC</sub> + 2.0 V for periods of up to 20ns.
- Minimum DC input voltage on A9 pin is -0.5V. During voltage transitions, A9 may overshoot V<sub>SS</sub> to -2V for periods of up to 20ns. Maximum DC input voltage on A9 is +13.5V which may overshoot to 14.0 V for periods up to 20ns.

**CAPACITANCE**

T<sub>A</sub> = +25°C

Parameter	Symbol	Conditions	Max	Unit
Address Input capacitance	CAD	V <sub>I/O</sub> = 0 V, f = 1.0 MHz	15	pF
Output Enable capacitance	COE	V <sub>IN</sub> = 0 V, f = 1.0 MHz	15	pF
Write Enable capacitance	CWE	V <sub>IN</sub> = 0 V, f = 1.0 MHz	15	pF
Chip Select capacitance	CCS	V <sub>IN</sub> = 0 V, f = 1.0 MHz	15	pF
Data I/O capacitance	CI/O	V <sub>I/O</sub> = 0 V, f = 1.0 MHz	15	pF

This parameter is guaranteed by design but not tested.

**DC CHARACTERISTICS — CMOS COMPATIBLE**

V<sub>CC</sub> = 5.0V, V<sub>SS</sub> = 0V, -55°C ≤ T<sub>A</sub> ≤ +125°C

Parameter	Symbol	Conditions	Min	Max	Unit
Input Leakage Current	I <sub>LI</sub>	V <sub>CC</sub> = 5.5, V <sub>IN</sub> = GND to V <sub>CC</sub>		10	µA
Output Leakage Current	I <sub>LOx32</sub>	V <sub>CC</sub> = 5.5, V <sub>IN</sub> = GND to V <sub>CC</sub>		10	µA
V <sub>CC</sub> Active Current for Read (1)	I <sub>CC1</sub>	CS# = V <sub>IL</sub> , OE# = V <sub>IH</sub> , f = 5MHz		50	mA
V <sub>CC</sub> Active Current for Program or Erase (2)	I <sub>CC2</sub>	CS# = V <sub>IL</sub> , OE# = V <sub>IH</sub>		60	mA
V <sub>CC</sub> Standby Current	I <sub>CC4</sub>	V <sub>CC</sub> = 5.5, CS# = V <sub>IH</sub> , f = 5MHz		1.6	mA
Output Low Voltage	V <sub>OL</sub>	I <sub>OL</sub> = 8.0 mA, V <sub>CC</sub> = 4.5		0.45	V
Output High Voltage	V <sub>OH1</sub>	I <sub>OH</sub> = -2.5 mA, V <sub>CC</sub> = 4.5	0.85 x V <sub>CC</sub>		V
Low V <sub>CC</sub> Lock-Out Voltage	V <sub>LKO</sub>		3.2	4.2	V

NOTES:

- The I<sub>CC</sub> current listed includes both the DC operating current and the frequency dependent component (at 5 MHz). The frequency component typically is less than 2 mA/MHz, with OE# at V<sub>IH</sub>.
- I<sub>CC</sub> active while Embedded Algorithm (program or erase) is in progress.
- DC test conditions: V<sub>IL</sub> = 0.3V, V<sub>IH</sub> = V<sub>CC</sub> - 0.3V



**AC CHARACTERISTICS – WRITE/ERASE/PROGRAM OPERATIONS, CS# CONTROLLED**

V<sub>CC</sub> = 5.0V, V<sub>SS</sub> = 0V, -55°C ≤ T<sub>A</sub> ≤ +125°C

Parameter	Symbol		-60		-70		-90		-120		-150		Unit
			Min	Max	Min	Max	Min	Max	Min	Max	Min	Max	
Write Cycle Time	t <sub>WAV</sub>	t <sub>WIC</sub>	60		70		90		120		150		ns
Write Enable Setup Time	t <sub>WLEL</sub>	t <sub>WIS</sub>	0		0		0		0		0		ns
Chip Select Pulse Width	t <sub>ELEH</sub>	t <sub>CP</sub>	40		45		45		50		50		ns
Address Setup Time	t <sub>AVEL</sub>	t <sub>AS</sub>	0		0		0		0		0		ns
Data Setup Time	t <sub>DVEH</sub>	t <sub>DS</sub>	40		45		45		50		50		ns
Data Hold Time	t <sub>HDX</sub>	t <sub>DH</sub>	0		0		0		0		0		ns
Address Hold Time	t <sub>ELAX</sub>	t <sub>AH</sub>	40		45		45		50		50		ns
Chip Select Pulse Width High	t <sub>EHEL</sub>	t <sub>CPH</sub>	20		20		20		20		20		ns
Duration of Byte Programming Operation (1)	t <sub>WHWH1</sub>			300		300		300		300		300	μs
Sector Erase Time (2)	t <sub>WHWH2</sub>			15		15		15		15		15	sec
Read Recovery Time	t <sub>RHEL</sub>		0		0		0		0		0		ns
Chip Programming Time				11		11		11		11		11	sec
Chip Erase Time (3)				64		64		64		64		64	sec

NOTES:

1. Typical value for t<sub>WHWH1</sub> is 7μs.
2. Typical value for t<sub>WHWH2</sub> is 1sec.
3. Typical value for Chip Erase time is 8sec.

**AC TEST CIRCUIT**

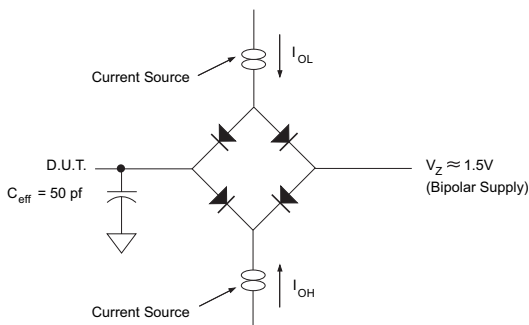

**AC Test Conditions**

Parameter	Typ	Unit
Input Pulse Levels	V <sub>IL</sub> = 0, V <sub>IH</sub> = 3.0	V
Input Rise and Fall	5	ns
Input and Output Reference Level	1.5	V
Output Timing Reference Level	1.5	V

Notes:

V<sub>Z</sub> is programmable from -2V to +7V.  
 I<sub>OL</sub> & I<sub>OH</sub> programmable from 0 to 16mA.  
 Tester Impedance Z<sub>0</sub> = 75 Ω.  
 V<sub>Z</sub> is typically the midpoint of V<sub>OH</sub> and V<sub>OL</sub>.  
 I<sub>OL</sub> & I<sub>OH</sub> are adjusted to simulate a typical resistive load circuit.  
 ATE tester includes jig capacitance.



**AC CHARACTERISTICS – WRITE/ERASE/PROGRAM OPERATIONS, WE# CONTROLLED**

V<sub>CC</sub> = 5.0V, -55°C ≤ T<sub>A</sub> ≤ +125°C

Parameter	Symbol		-60		-70		-90		-120		-150		Unit
			Min	Max	Min	Max	Min	Max	Min	Max	Min	Max	
Write Cycle Time	t <sub>AVAV</sub>	t <sub>WC</sub>	60		70		90		120		150		ns
Chip Select Setup Time	t <sub>ELWL</sub>	t <sub>CS</sub>	0		0		0		0		0		ns
Write Enable Pulse Width	t <sub>WLWH</sub>	t <sub>WP</sub>	40		45		45		50		50		ns
Address Setup Time	t <sub>AVWH</sub>	t <sub>AS</sub>	0		0		0		0		0		ns
Data Setup Time	t <sub>DVWH</sub>	t <sub>DS</sub>	40		45		45		50		50		ns
Data Hold Time	t <sub>WHDX</sub>	t <sub>DH</sub>	0		0		0		0		0		ns
Address Hold Time	t <sub>WHAX</sub>	t <sub>AH</sub>	40		45		45		50		50		ns
Write Enable Pulse Width High	t <sub>HWHL</sub>	t <sub>WPH</sub>	20		20		20		20		20		ns
Duration of Byte Programming Operation (1)	t <sub>WHWH1</sub>			300		300		300		300		300	μs
Sector Erase Time (2)	t <sub>WHWH2</sub>			15		15		15		15		15	sec
Read Recovery Time before Write	t <sub>GHWL</sub>		0		0		0		0		0		ms
VCC Set-up Time		t <sub>VCS</sub>	50		50		50		50		50		μs
Chip Programming Time				11		11		11		11		11	sec
Output Enable Setup Time		t <sub>OES</sub>	0		0		0		0		0		ns
Output Enable Hold Time (4)		t <sub>OEH</sub>	10		10		10		10		10		ns
Chip Erase Time (3)				64		64		64		64		64	sec

NOTES:

1. Typical value for t<sub>WHWH1</sub> is 7μs.
2. Typical value for t<sub>WHWH2</sub> is 1sec.
3. Typical value for Chip Erase time is 8sec.
4. For Toggle and Data# Polling.

**AC CHARACTERISTICS – READ ONLY OPERATIONS**

V<sub>CC</sub> = 5.0V, -55°C ≤ T<sub>A</sub> ≤ +125°C

Parameter	Symbol		-60		-70		-90		-120		-150		Unit
			Min	Max	Min	Max	Min	Max	Min	Max	Min	Max	
Read Cycle Time	t <sub>AVAV</sub>	t <sub>RC</sub>	60		70		90		120		150		ns
Address Access Time	t <sub>AVQV</sub>	t <sub>ACC</sub>		60		70		90		120		150	ns
Chip Select Access Time	t <sub>ELQV</sub>	t <sub>CE</sub>		60		70		90		120		150	ns
Output Enable to Output Valid	t <sub>GLQV</sub>	t <sub>OE</sub>		35		35		35		50		55	ns
Chip Select to Output High Z (1)	t <sub>EHQZ</sub>	t <sub>DF</sub>		20		20		20		30		35	ns
Output Enable High to Output High Z (1)	t <sub>GHQZ</sub>	t <sub>DF</sub>		20		20		20		30		35	ns
Output Hold from Address, CS# or OE# Change, whichever is First	t <sub>AXQX</sub>	t <sub>OH</sub>	0		0		0		0		0		ns

NOTES:

1. Guaranteed by design, but not tested



AC WAVEFORMS FOR READ OPERATIONS

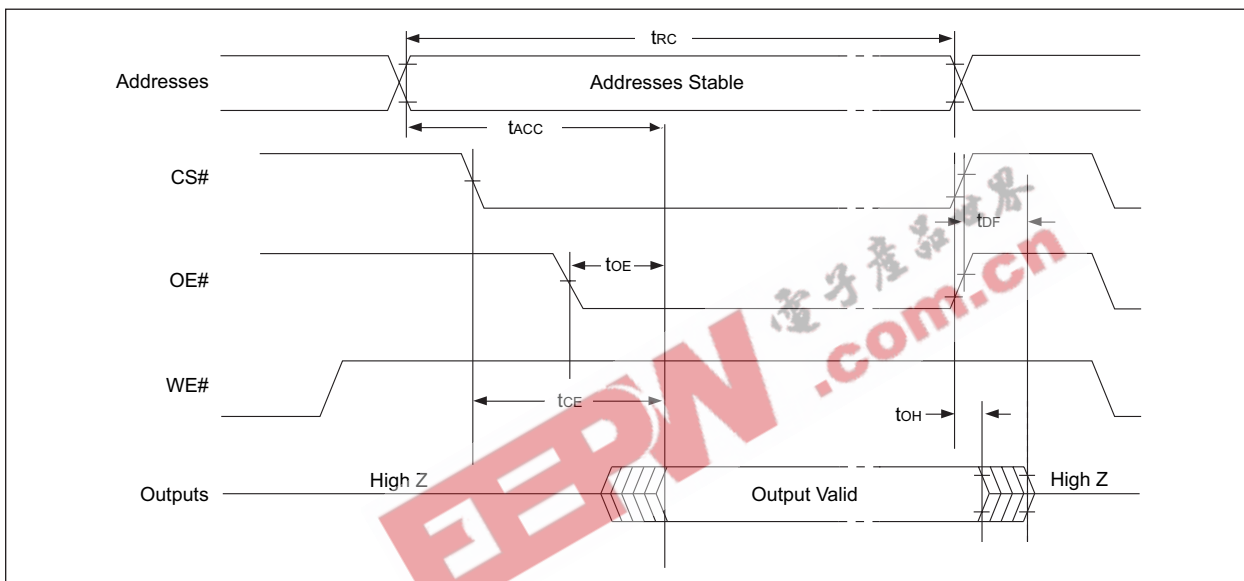

WRITE/ERASE/PROGRAM OPERATION, WE# CONTROLLED

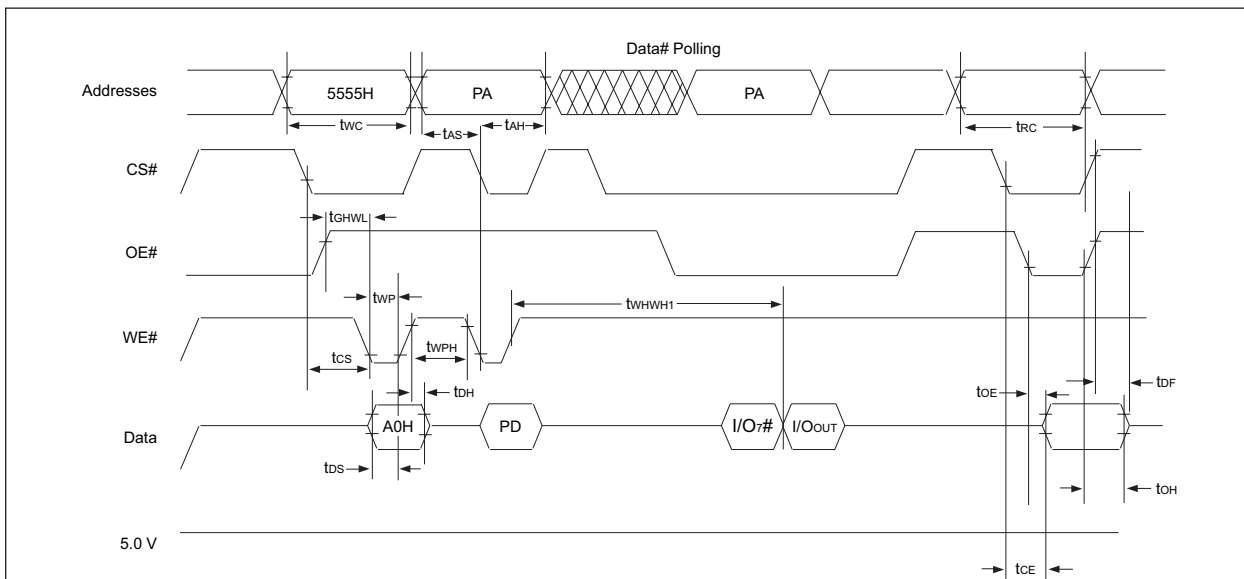

NOTES:

- 1. PA is the address of the memory location to be programmed.
- 2. PD is the data to be programmed at byte address.
- 3. I/O# is the output of the complement of the data written to the device.
- 4. I/Oout is the output of the data written to the device.
- 5. Figure indicates last two bus cycles of four bus cycle sequence.



AC WAVEFORMS CHIP/SECTOR ERASE OPERATIONS

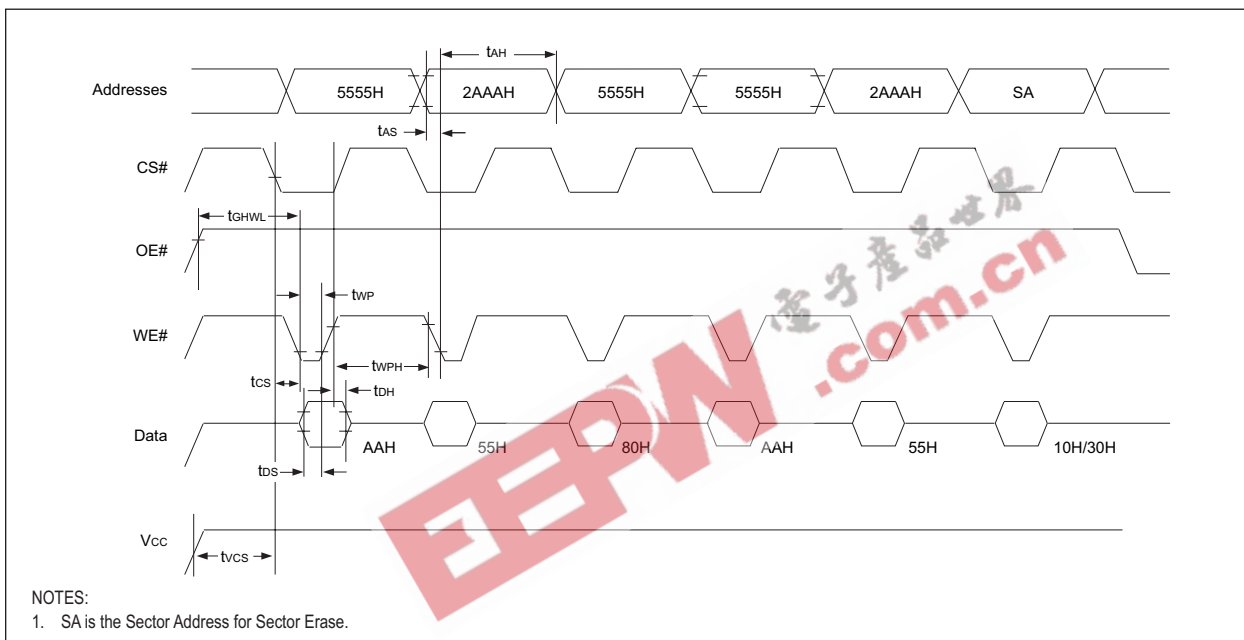

AC WAVEFORMS FOR DATA# POLLING DURING EMBEDDED ALGORITHM OPERATIONS

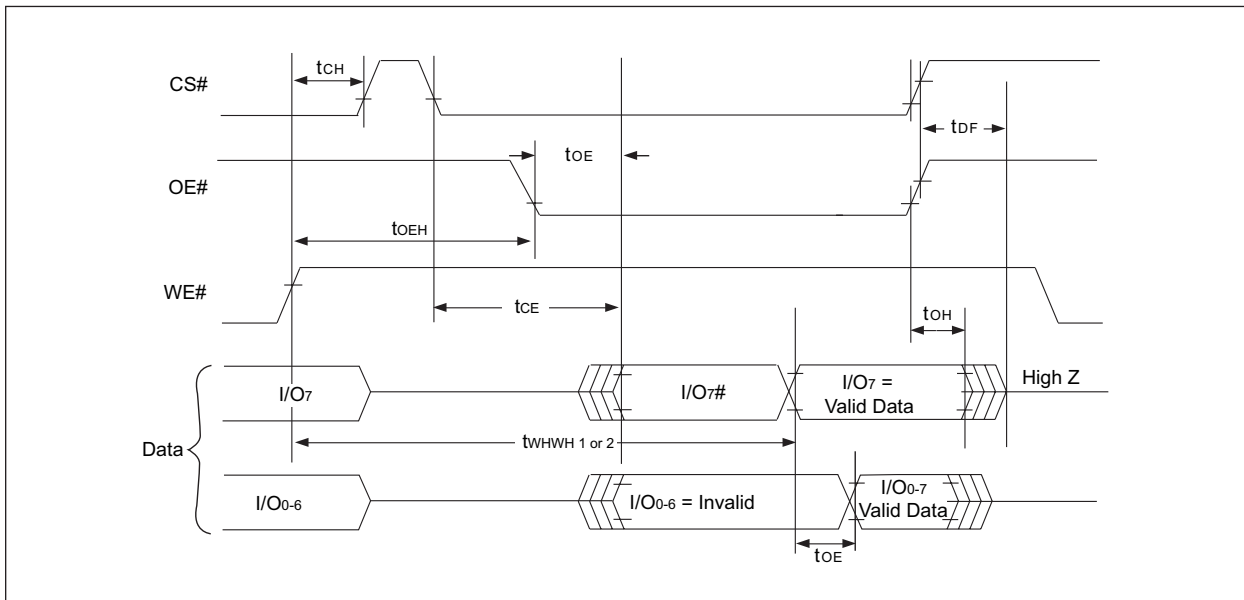



ALTERNATE CS# CONTROLLED PROGRAMMING OPERATION TIMINGS

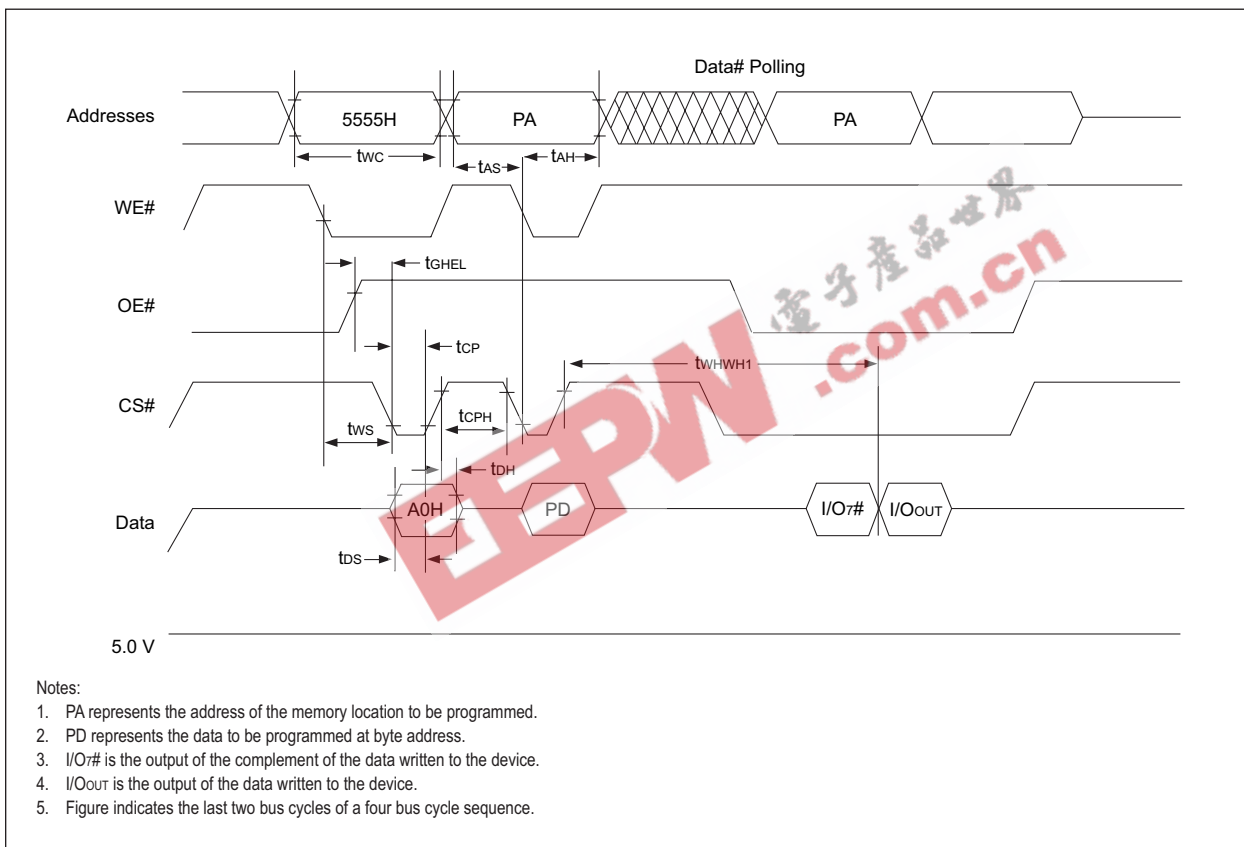



PACKAGE 101: 32 LEAD, CERAMIC SOJ

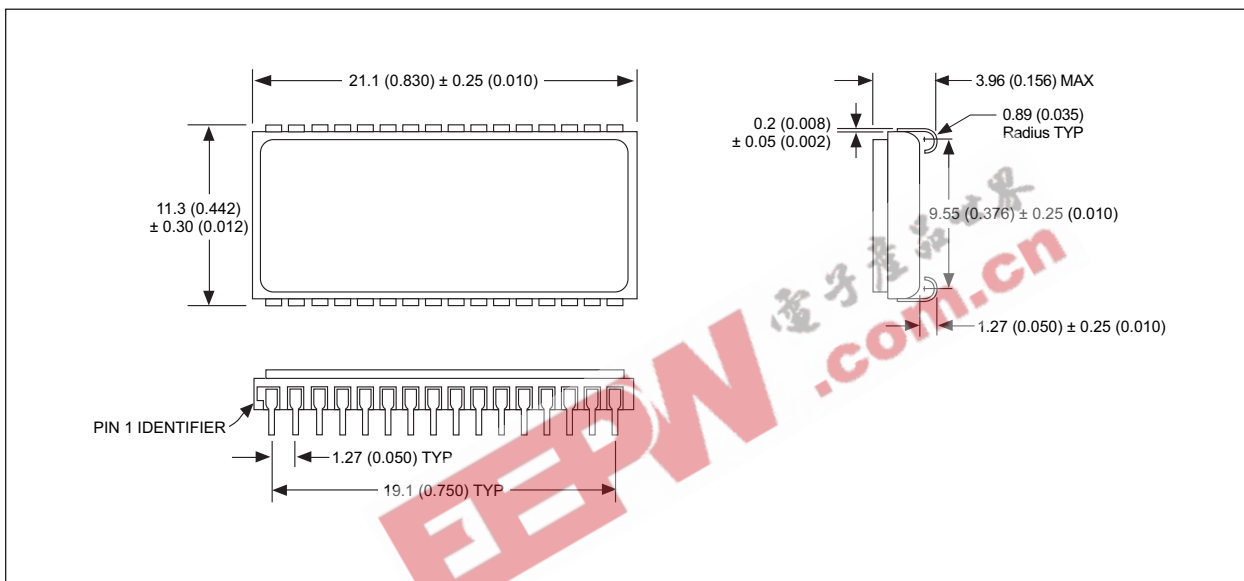

ALL LINEAR DIMENSIONS ARE MILLIMETERS AND PARENTHETICALLY IN INCHES

PACKAGE 220: 32 LEAD, CERAMIC FLATPACK

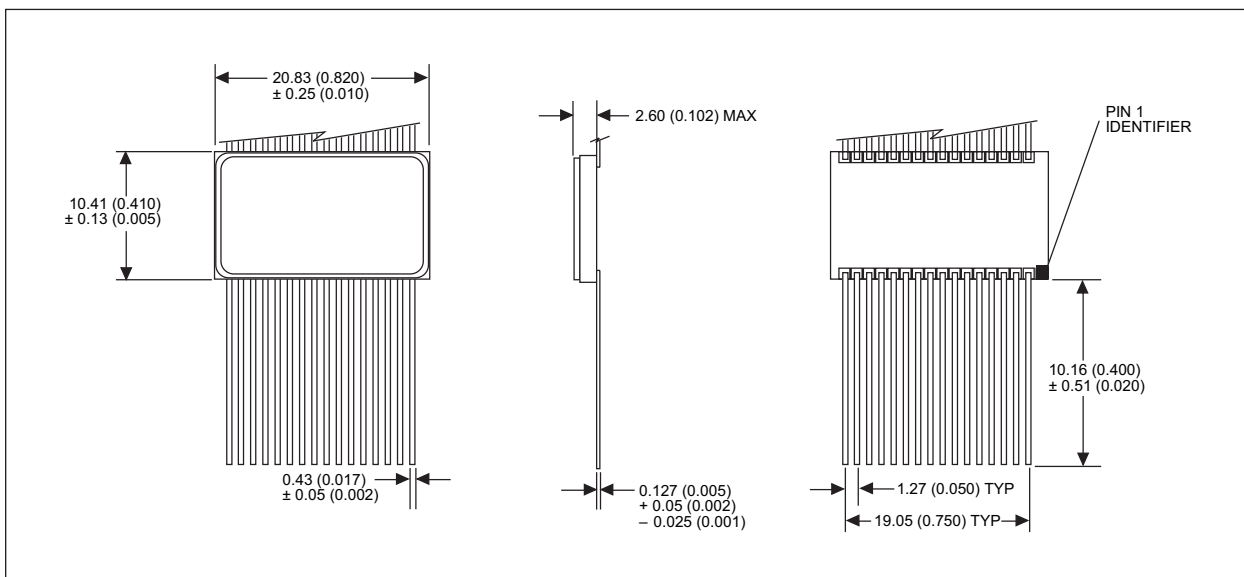

ALL LINEAR DIMENSIONS ARE MILLIMETERS AND PARENTHETICALLY IN INCHES





**PACKAGE 300: 32 PIN, CERAMIC DIP, SINGLE CAVITY SIDE BRAZED**

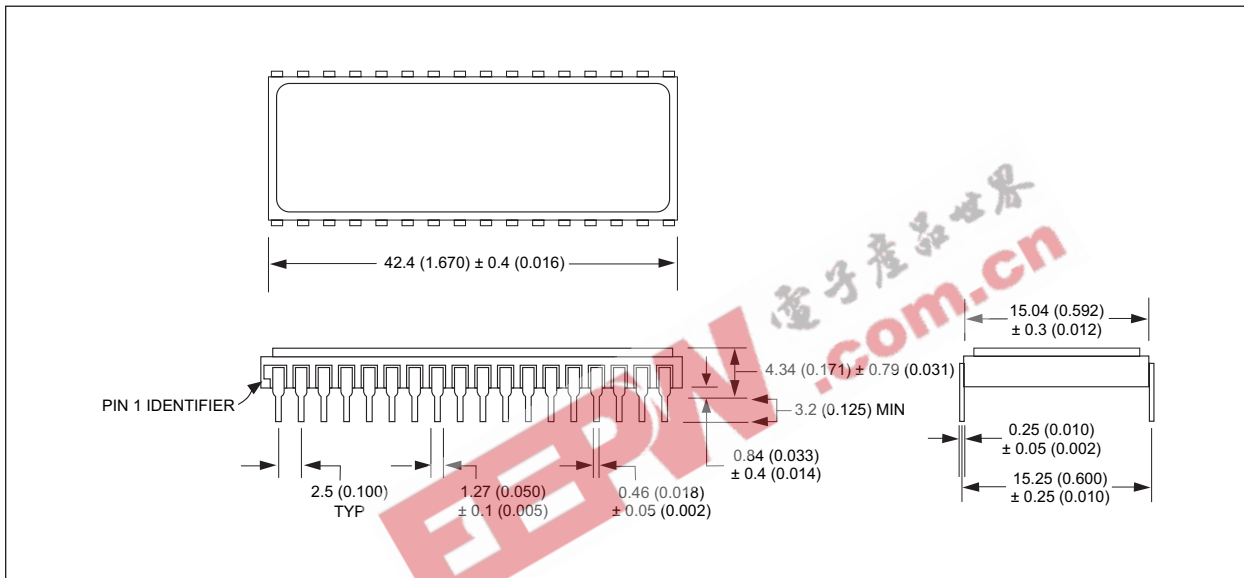

ALL LINEAR DIMENSIONS ARE MILLIMETERS AND PARENTHETICALLY IN INCHES



**PACKAGE 601: 32 PIN, RECTANGULAR CERAMIC LEADLESS CHIP CARRIER**

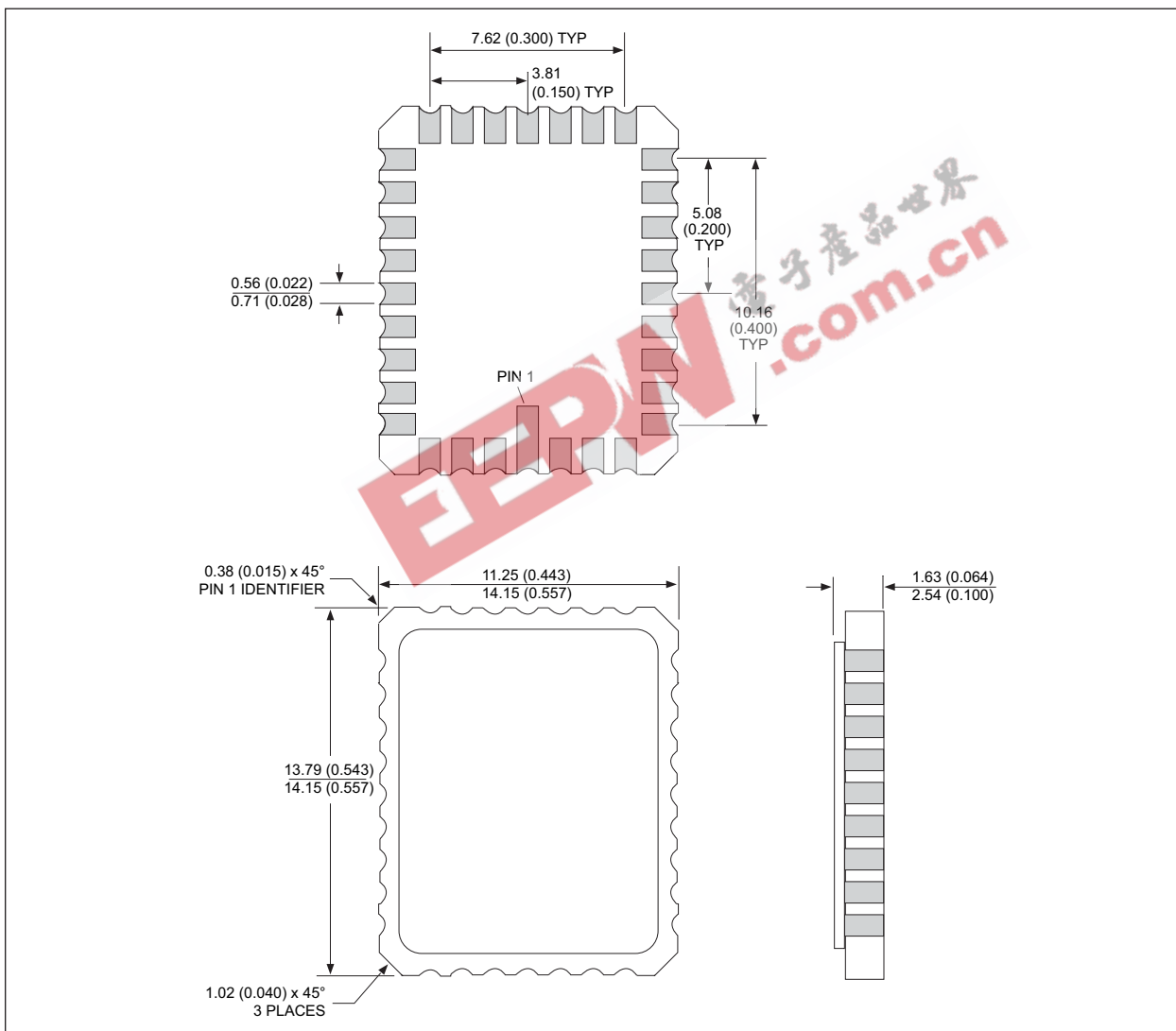

ALL LINEAR DIMENSIONS ARE MILLIMETERS AND PARENTHETICALLY IN INCHES



**ORDERING INFORMATION**

W M F 512K 8 - XXX X X 5 X

WHITE ELECTRONIC DESIGNS CORP.

MONOLITHIC

Flash

ORGANIZATION, 512K x 8

ACCESS TIME (ns)

PACKAGE TYPE:

- C = 32 Pin Ceramic DIP (Package 300)
- CL = 32 Pin Rectangular Ceramic Leadless Chip Carrier (Package 601)
- DE = 32 Lead Ceramic SOJ (Package 101)
- FE = 32 Lead Flatpack (Package 220)

DEVICE GRADE:

- M = Military Screened -55°C to +125°C
- I = Industrial -40°C to +85°C
- C = Commercial 0°C to +70°C

V<sub>PP</sub> PROGRAMMING VOLTAGE

5 = 5V

LEAD FINISH:

- Blank = Gold plated leads
- A = Solder dip leads

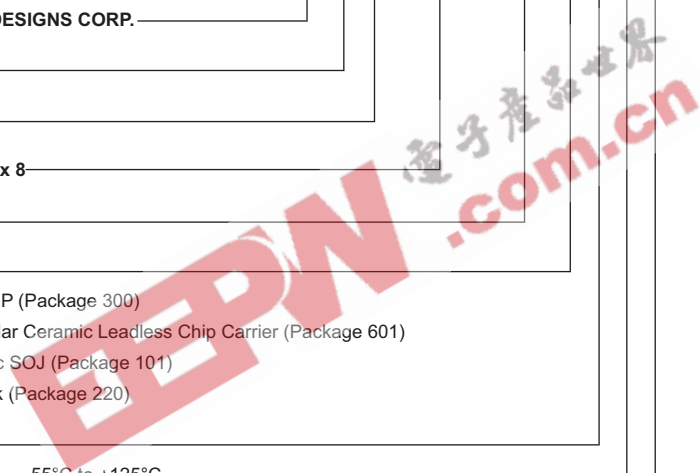



DEVICE TYPE	SECTOR SIZE	SPEED	PACKAGE	SMD NO.
512K x 8 Flash Monolithic	64KByte	150ns	32 pin DIP (C)	5962-96692 01HXX
512K x 8 Flash Monolithic	64KByte	120ns	32 pin DIP (C)	5962-96692 02HXX
512K x 8 Flash Monolithic	64KByte	90ns	32 pin DIP (C)	5962-96692 03HXX
512K x 8 Flash Monolithic	64KByte	70ns	32 pin DIP (C)	5962-96692 04HXX
512K x 8 Flash Monolithic	64KByte	150ns	32 lead SOJ (DE)	5962-96692 01HYX
512K x 8 Flash Monolithic	64KByte	120ns	32 lead SOJ (DE)	5962-96692 02HYX
512K x 8 Flash Monolithic	64KByte	90ns	32 lead SOJ (DE)	5962-96692 03HYX
512K x 8 Flash Monolithic	64KByte	70ns	32 lead SOJ (DE)	5962-96692 04HYX
512K x 8 Flash Monolithic	64KByte	150ns	32 lead Flatpack (FE)	5962-96692 01HUX
512K x 8 Flash Monolithic	64KByte	120ns	32 lead Flatpack (FE)	5962-96692 02HUX
512K x 8 Flash Monolithic	64KByte	90ns	32 lead Flatpack (FE)	5962-96692 03HUX
512K x 8 Flash Monolithic	64KByte	70ns	32 lead Flatpack (FE)	5962-96692 04HUX
512K x 8 Flash Monolithic	64KByte	150ns	32 lead Flatpack (FF)	5962-96692 01HTX
512K x 8 Flash Monolithic	64KByte	120ns	32 lead Flatpack (FF)	5962-96692 02HTX
512K x 8 Flash Monolithic	64KByte	90ns	32 lead Flatpack (FF)	5962-96692 03HTX
512K x 8 Flash Monolithic	64KByte	70ns	32 lead Flatpack (FF)	5962-96692 04HTX

**Document Title**

512K x 8 Flash Monolithic

**Revision History**

Rev #	History	Release Date	Status
Rev 1	Initial Release	September 1996	Preliminary
	Changes (Pg. 1)	May 1997	Final
	1.1 Change status to Final		
	Changes (Pg. 1)	February 1998	Final
	1.1 Correct typo of Ceramic		
	Changes (Pg. 10)	April 1998	Final
	1.1 Remove pedestal from Flatpack package drawing		
Rev 2	Changes (Pg. 1)	February 1999	Final
	1.1 Change name from 'FP' to Flatpack		
	Changes (Pg. 1, 2, 3, 4, 13)	May 1999	Final
	2.1 Change number of max program/erases to 1,000,000		
	2.2 Change temperature of max program/erases to 25C		
	2.3 Absolute Maximum Ratings Table:		
	2.3.1 Change Data Retention to 20years		
	2.3.2 Change Endurance to 100,000 cycles minimum		
	2.4 Write/Erase/Program Operations Tables:		
	2.4.1 Change $t_{WHWH1}$ to 300 $\mu$ s		
	2.4.2 Add Note (1) Typical $t_{WHWH1} = 7\mu$ s		
	2.4.3 Change $t_{WHWH2}$ to 15sec		
	2.4.4 Add Note (2) Typical $t_{WHWH2} = 1$ sec		
	2.4.5 Change Chip Programming Time to 11 sec		
	2.4.6 Change Chip Erase Time to 64 sec		
	2.4.7 Add Note (3) Chip Erase Time = 8 sec		
	2.5 Ordering Information		
2.5.1 Change Company Name to White EDC			
2.6 Change Title Style to new WEDC look			
Rev 3	Changes (Pg. 1, 2, 10, 12, 13)	May 1999	Final
	3.1 Change package 206 to package 220		
	3.2 Remove temperature range notice for Endurance		
Rev 4	3.3 Change width spec to 0.457" minimum for package 601		
	Changes (Pg. 1, 3, 4)	January 2003	Final
4.1 Add 60ns speed grade option			
Rev 5	Changes (Pg. 1, 11, 13)	April 2005	Final
	5.1 Add 'T' case outline for 'FF' package		
Rev 6	Changes (Pg. 1, 13)	November 2005	Final
	6.1 Change revision history Rev 2.4.1 to 300 $\mu$ s		
6.2 Change revision history Rev 2.4.2 to 7 $\mu$ s			