



128Kx8 MONOLITHIC FLASH, SMD 5962-96690

FEATURES

- Access Times of 50*, 60, 70, 90, 120, 150ns
- Packaging
 - 32 lead, Hermetic Ceramic, 0.400" SOJ (Package 101)
 - 32 pin, Hermetic Ceramic, 0.600" DIP (Package 300)
 - 32 lead, Flatpack (Package 220)
 - 32 lead, Formed Flatpack (Package 221)
 - 32 pin, Rectangular Ceramic Leadless Chip Carrier (Package 601)
- 100,000 Erase/Program Cycles Minimum
- Sector Erase Architecture
 - 8 equal size sectors of 16KBytes each
 - Any combination of sectors can be concurrently erased. Also supports full chip erase
- Organized as 128Kx8
- Commercial, Industrial and Military Temperature Ranges
- 5 Volt Programming. 5V ±10% Supply.
- Low Power CMOS
- Embedded Erase and Program Algorithms
- TTL Compatible Inputs and CMOS Outputs
- Page Program Operation and Internal Program Control Time.

Note: For programming information refer to Flash Programming 1M5 Application Note.

** The access time of 50ns is available in Industrial and Commercial temperature ranges only.*

PIN CONFIGURATION FOR WMF128K8-XXX5

32 DIP
32 CSOJ
32 FLATPACK
TOP VIEW

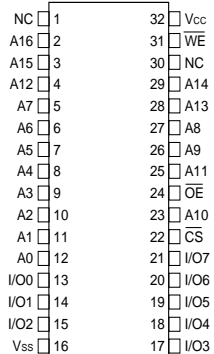

PIN CONFIGURATION FOR WMF128K8-XCLX5

32 CLCC
TOP VIEW

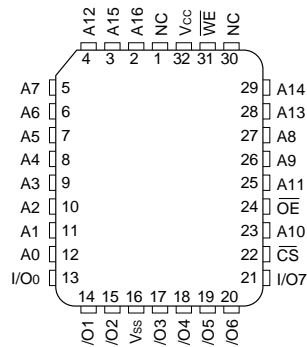

PIN DESCRIPTION

A0-16	Address Inputs
I/O0-7	Data Input/Output
\overline{CS}	Chip Select
\overline{OE}	Output Enable
\overline{WE}	Write Enable
Vcc	+5.0V Power
Vss	Ground



ABSOLUTE MAXIMUM RATINGS (1)

Parameter		Unit
Operating Temperature	-55 to +125	°C
Supply Voltage Range (Vcc)	-2.0 to +7.0	V
Signal voltage range (any pin except A9) (2)	-2.0 to +7.0	V
Storage Temperature Range	-65 to +150	°C
Lead Temperature (soldering, 10 seconds)	+300	°C
Data Retention Mil Temp	10	years
Endurance (write/erase cycles) Mil Temp	10,000 min.	cycles
A9 Voltage for sector protect (V _{ID}) (3)	-2.0 to +14.0	V

RECOMMENDED OPERATING CONDITIONS

Parameter	Symbol	Min	Max	Unit
Supply Voltage	V _{CC}	4.5	5.5	V
Input High Voltage	V _{IH}	2.0	V _{CC} + 0.3	V
Input Low Voltage	V _{IL}	-0.5	+0.8	V
Operating Temp. (Mil.)	T _A	-55	+125	°C
Operating Temp. (Ind.)	T _A	-40	+85	°C
A9 Voltage for Sector Protect	V _{ID}	11.5	12.5	V

CAPACITANCE
(T_A = +25°C)

Parameter	Symbol	Conditions	Max	Unit
Address Input capacitance	C _{Ad}	V _{I/O} = 0 V, f = 1.0 MHz	15	pF
Output Enable capacitance	C _{OE}	V _{IN} = 0 V, f = 1.0 MHz	15	pF
Write Enable capacitance	C _{WE}	V _{IN} = 0 V, f = 1.0 MHz	15	pF
Chip Select capacitance	C _{CS}	V _{IN} = 0 V, f = 1.0 MHz	15	pF
Data I/O capacitance	C _{I/O}	V _{I/O} = 0 V, f = 1.0 MHz	15	pF

This parameter is guaranteed by design but not tested.

NOTES:

- Stresses above the absolute maximum rating may cause permanent damage to the device. Extended operation at the maximum levels may degrade performance and affect reliability.
- Minimum DC voltage on input or I/O pins is -0.5V. During voltage transitions, inputs may overshoot V_{SS} to -2.0 V for periods of up to 20ns. Maximum DC voltage on output and I/O pins is V_{CC} + 0.5V. During voltage transitions, outputs may overshoot to V_{CC} + 2.0 V for periods of up to 20ns.
- Minimum DC input voltage on A9 pin is -0.5V. During voltage transitions, A9 may overshoot V_{SS} to -2V for periods of up to 20ns. Maximum DC input voltage on A9 is +13.5V which may overshoot to 14.0 V for periods up to 20ns.

DC CHARACTERISTICS - CMOS COMPATIBLE
(V_{CC} = 5.0V, V_{SS} = 0V, T_A = -55°C to +125°C)

Parameter	Symbol	Conditions	Min	Max	Unit
Input Leakage Current	I _{LI}	V _{CC} = 5.5, V _{IN} = GND to V _{CC}		10	µA
Output Leakage Current	I _{LO}	V _{CC} = 5.5, V _{IN} = GND to V _{CC}		10	µA
V _{CC} Active Current for Read (1)	I _{CC1}	$\overline{CS} = V_{IL}, \overline{OE} = V_{IH}$		35	mA
V _{CC} Active Current for Program or Erase (2)	I _{CC2}	$\overline{CS} = V_{IL}, \overline{OE} = V_{IH}$		50	mA
V _{CC} Standby Current	I _{CC3}	V _{CC} = 5.5, $\overline{CS} = V_{IH}, f = 5\text{MHz}$		1.6	mA
Output Low Voltage	V _{OL}	I _{OL} = 8.0 mA, V _{CC} = 4.5		0.45	V
Output High Voltage	V _{OH1}	I _{OH} = -2.5 mA, V _{CC} = 4.5	0.85 x V _{CC}		V
Output High Voltage	V _{OH2}	I _{OH} = -100 µA, V _{CC} = 4.5	V _{CC} - 0.4		V
Low V _{CC} Lock Out Voltage	V _{LKO}		3.2		V

NOTES:

- The I_{CC} current listed includes both the DC operating current and the frequency dependent component (at 5 MHz). The frequency component typically is less than 2 mA/MHz, with \overline{OE} at V_{IH}.
- I_{CC} active while Embedded Algorithm (program or erase) is in progress.
- DC test conditions: V_{IL} = 0.3V, V_{IH} = V_{CC} - 0.3V

AC TEST CIRCUIT

The diagram shows an AC test circuit. It features a bridge-like structure with four diodes. A D.U.T. (Device Under Test) is connected to the bridge. A current source is connected to the top node, and another current source is connected to the bottom node. A bipolar supply (V_Z ≈ 1.5V) is connected to the bridge. The effective capacitance (C_{eff}) is 50 pF.

AC TEST CONDITIONS

Parameter	Typ	Unit
Input Pulse Levels	V _{IL} = 0, V _{IH} = 3.0	V
Input Rise and Fall	5	ns
Input and Output Reference Level	1.5	V
Output Timing Reference Level	1.5	V

NOTES:
V_Z is programmable from -2V to +7V.
I_{OL} & I_{OH} programmable from 0 to 16mA.
Tester Impedance Z₀ = 75 Ω.
V_Z is typically the midpoint of V_{OH} and V_{OL}.
I_{OL} & I_{OH} are adjusted to simulate a typical resistive load circuit.
ATE tester includes jig capacitance.



AC CHARACTERISTICS – WRITE/ERASE/PROGRAM OPERATIONS, \overline{WE} CONTROLLED
 (V_{CC} = 5.0V, V_{SS} = 0V, T_A = -55°C to +125°C)

Parameter	Symbol		-50		-60		-70		-90		-120		-150		Unit
			Min	Max	Min	Max	Min	Max	Min	Max	Min	Max	Min	Max	
Write Cycle Time	t _{AVAV}	t _{WC}	50		60		70		90		120		150		ns
Chip Select Setup Time	t _{ELWL}	t _{CS}	0		0		0		0		0		0		ns
Write Enable Pulse Width	t _{WLWH}	t _{WP}	25		30		35		45		50		50		ns
Address Setup Time	t _{AVWL}	t _{AS}	0		0		0		0		0		0		ns
Data Setup Time	t _{DVWH}	t _{DS}	25		30		30		45		50		50		ns
Data Hold Time	t _{WHDX}	t _{DH}	0		0		0		0		0		0		ns
Address Hold Time	t _{WLAX}	t _{AH}	40		45		45		45		50		50		ns
Chip Select Hold Time	t _{WHEH}	t _{CH}	0		0		0		0		0		0		ns
Write Enable Pulse Width High	t _{WHWL}	t _{WPH}	20		20		20		20		20		20		ns
Duration of Byte Programming Operation (min)	t _{WHWH1}		14		14		14		14		14		14		μs
Sector Erase Time	t _{WHWH2}		2.2	60	2.2	60	2.2	60	2.2	60	2.2	60	2.2	60	sec
Read Recovery Time Before Write	t _{GHWL}		0		0		0		0		0		0		ns
V _{CC} Setup Time	t _{VCS}		50		50		50		50		50		50		μs
Chip Programming Time				12.5		12.5		12.5		12.5		12.5		12.5	sec
Output Enable Setup Time		t _{OES}	0		0		0		0		0		0		ns
Output Enable Hold Time (1)		t _{OEH}	10		10		10		10		10		10		ns

1. For Toggle and Data Polling.

AC CHARACTERISTICS – READ ONLY OPERATIONS
 (V_{CC} = 5.0V, V_{SS} = 0V, T_A = -55°C to +125°C)

Parameter	Symbol		-50		-60		-70		-90		-120		-150		Unit
			Min	Max	Min	Max	Min	Max	Min	Max	Min	Max			
Read Cycle Time	t _{AVAV}	t _{RC}	50		60		70		90		120		150		ns
Address Access Time	t _{AVQV}	t _{ACC}		50		60		70		90		120		150	ns
Chip Select Access Time	t _{ELQV}	t _{CE}		50		60		70		90		120		150	ns
\overline{OE} to Output Valid	t _{GLQV}	t _{OE}		25		30		35		40		50		55	ns
Chip Select to Output High Z (1)	t _{EHQZ}	t _{DF}		20		20		20		25		30		35	ns
\overline{OE} High to Output High Z (1)	t _{GHQZ}	t _{DF}		20		20		20		25		30		35	ns
Output Hold from Address, \overline{CS} or \overline{OE} Change, whichever is first	t _{AXQX}	t _{OH}	0		0		0		0		0		0		ns

1. Guaranteed by design, not tested.



AC CHARACTERISTICS – WRITE/ERASE/PROGRAM OPERATIONS, \overline{CS} CONTROLLED

(V_{CC} = 5.0V, V_{SS} = 0V, T_A = -55°C to +125°C)

Parameter	Symbol		-50		-60		-70		-90		-120		-150		Unit
			Min	Max	Min	Max	Min	Max	Min	Max	Min	Max	Min	Max	
Write Cycle Time	t _{AVAV}	t _{WC}	50		60		70		90		120		150		ns
\overline{WE} Setup Time	t _{WLLEL}	t _{WS}	0		0		0		0		0		0		ns
\overline{CS} Pulse Width	t _{ELEH}	t _{CP}	25		30		35		45		50		50		ns
Address Setup Time	t _{AVEL}	t _{AS}	0		0		0		0		0		0		ns
Data Setup Time	t _{DVEH}	t _{DS}	25		30		30		45		50		50		ns
Data Hold Time	t _{EHDX}	t _{DH}	0		0		0		0		0		0		ns
Address Hold Time	t _{ELAX}	t _{AH}	40		45		45		45		50		50		ns
\overline{WE} Hold from \overline{WE} High	t _{EHWH}	t _{WH}	0		0		0		0		0		0		ns
\overline{CS} Pulse Width High	t _{EHEL}	t _{CPH}	20		20		20		20		20		20		ns
Duration of Programming Operation	t _{WHWH1}		14		14		14		14		14		14		μs
Duration of Erase Operation	t _{WHWH2}		2.2	60	2.2	60	2.2	60	2.2	60	2.2	60	2.2	60	sec
Read Recovery before Write	t _{GHLEL}		0		0		0		0		0		0		ns
Chip Programming Time				12.5		12.5		12.5		12.5		12.5		12.5	sec



AC WAVEFORMS FOR READ OPERATIONS

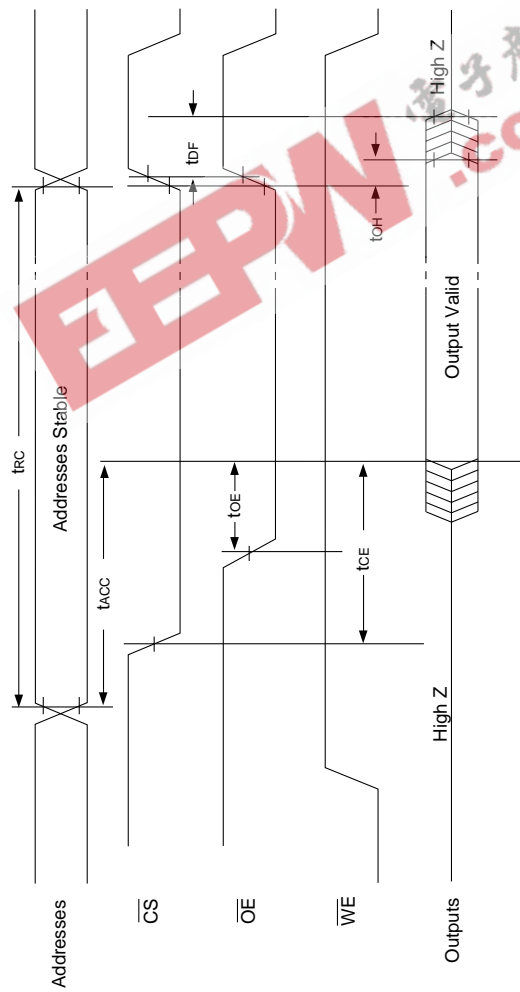



WRITE/ERASE/PROGRAM OPERATION, WE CONTROLLED

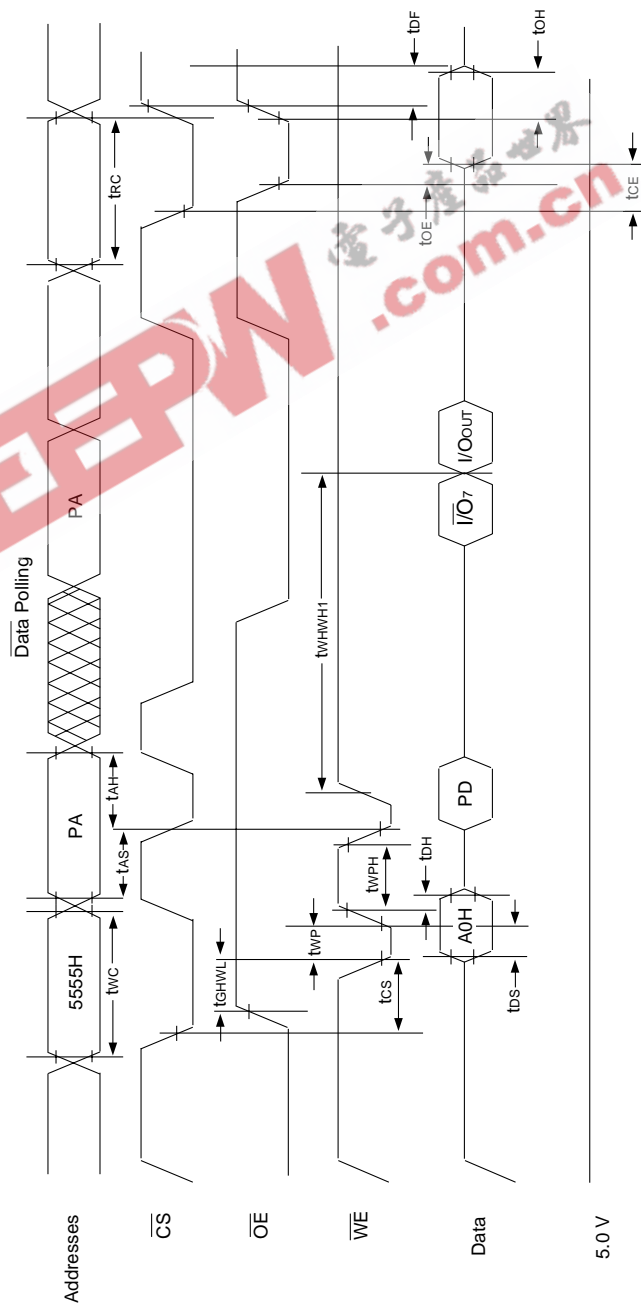

NOTES:

1. PA is the address of the memory location to be programmed.
2. PD is the data to be programmed at byte address.
3. I/O7 is the output of the complement of the data written to the device.
4. I/Oout is the output of the data written to the device.
5. Figure indicates last two bus cycles of four bus cycle sequence.



AC WAVEFORMS CHIP/SECTOR ERASE OPERATIONS

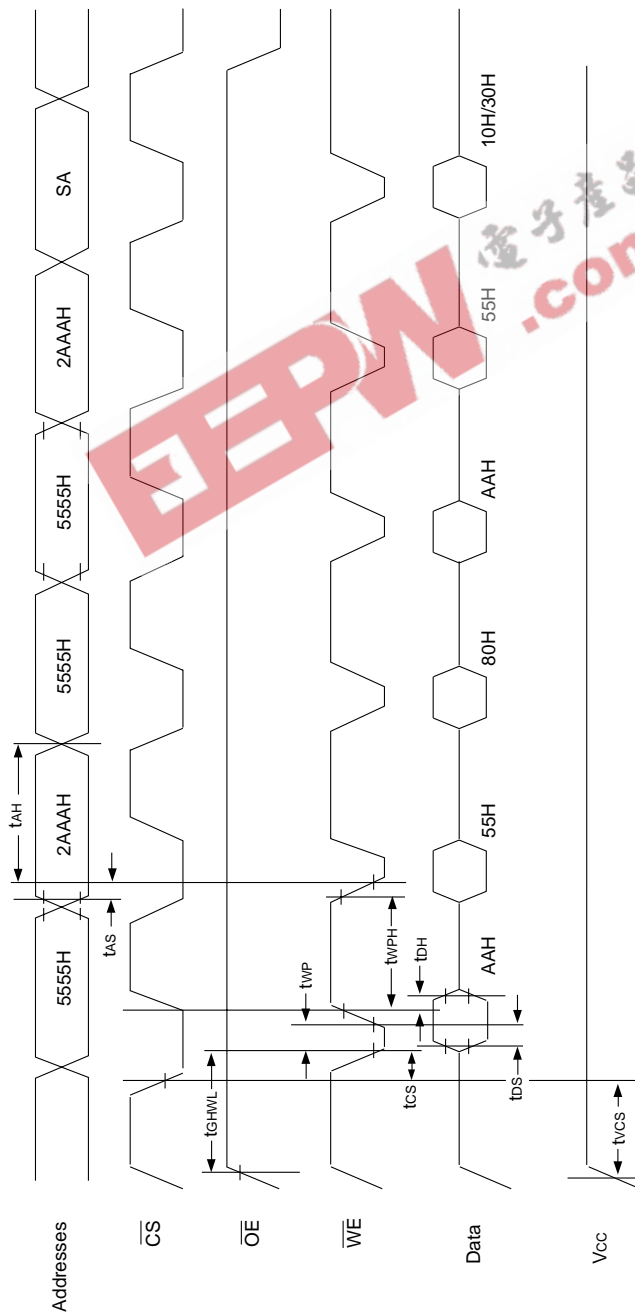

NOTES:
1. SA is the sector address for Sector Erase.



AC WAVEFORMS FOR DATA POLLING DURING EMBEDDED ALGORITHM OPERATIONS

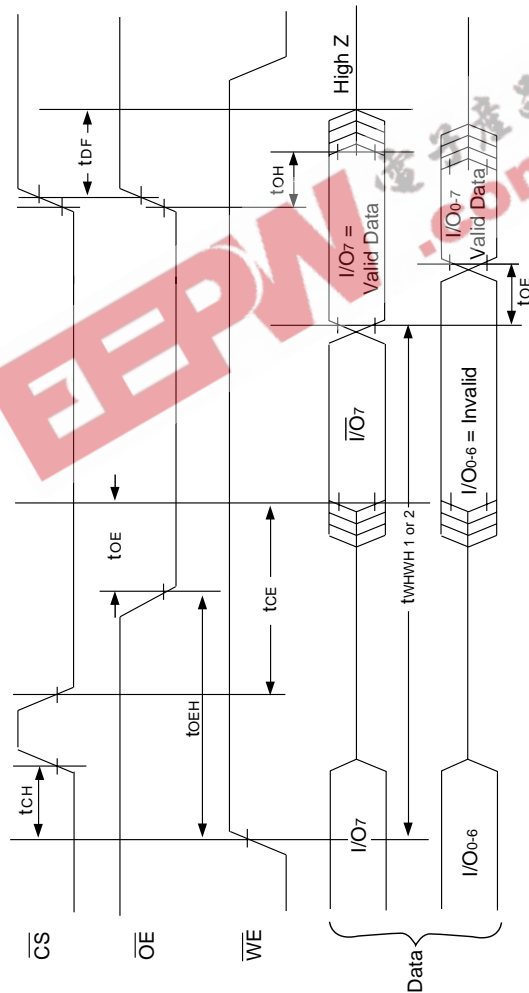



WRITE/ERASE/PROGRAM OPERATION, \overline{CS} CONTROLLED

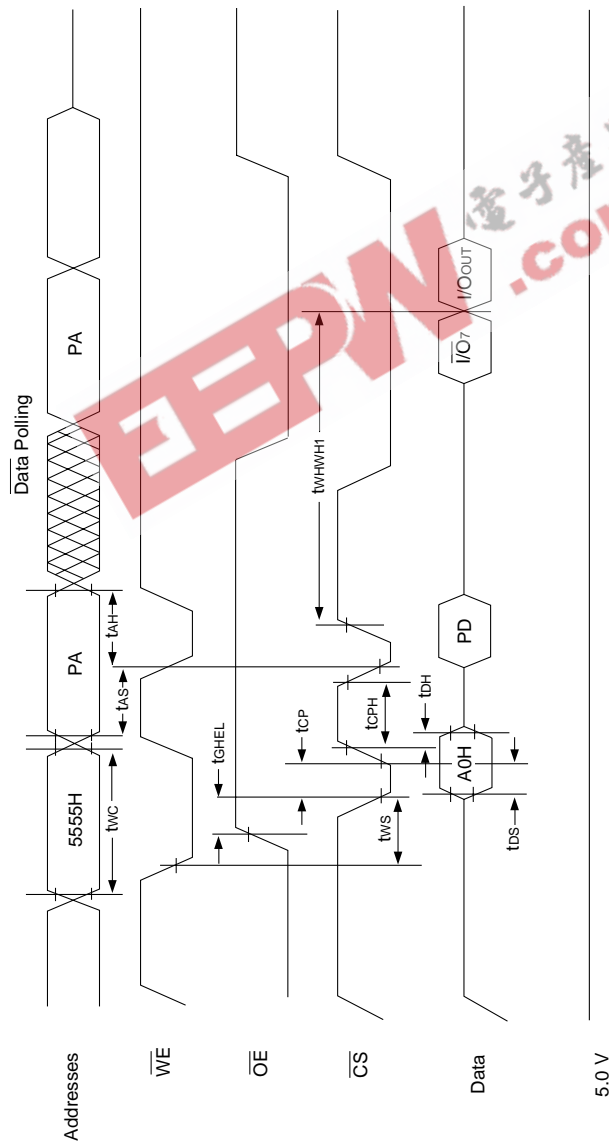

NOTES:

- 1. PA represents the address of the memory location to be programmed.
- 2. PD represents the data to be programmed at byte address.
- 3. $\overline{I/O}$ is the output of the complement of the data written to the device.
- 4. $\overline{I/Oout}$ is the output of the data written to the device.
- 5. Figure indicates the last two bus cycles of a four bus cycle sequence.



PACKAGE 101: 32 LEAD, CERAMIC SOJ

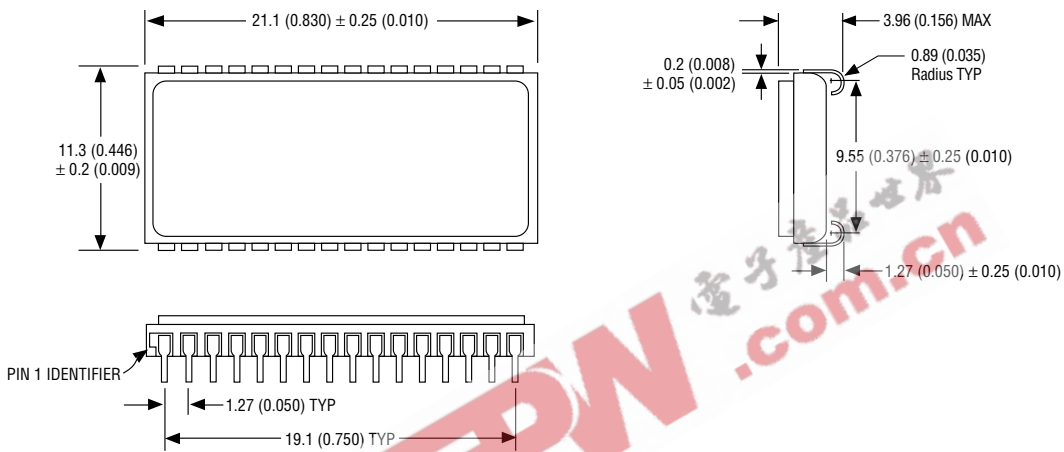

ALL LINEAR DIMENSIONS ARE MILLIMETERS AND PARENTHETICALLY IN INCHES

PACKAGE 220: 32 LEAD, CERAMIC FLATPACK

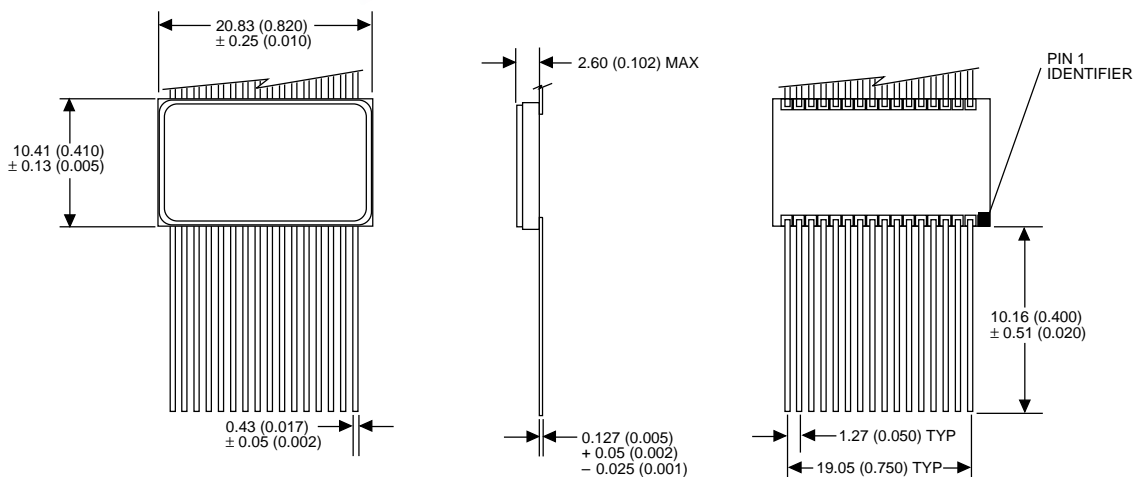

ALL LINEAR DIMENSIONS ARE MILLIMETERS AND PARENTHETICALLY IN INCHES



PACKAGE 221: 32 LEAD, FORMED CERAMIC FLATPACK

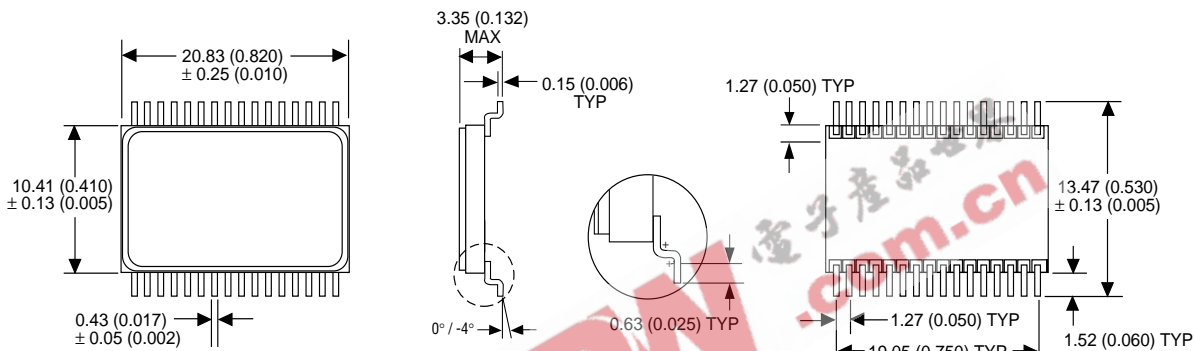

ALL LINEAR DIMENSIONS ARE MILLIMETERS AND PARENTHETICALLY IN INCHES

PACKAGE 300: 32 PIN, CERAMIC DIP, SINGLE CAVITY SIDE BRAZED

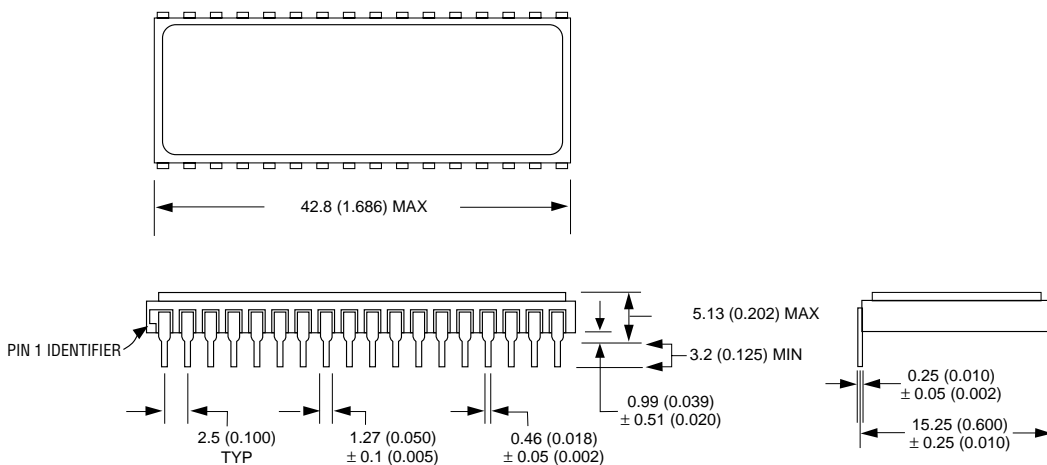

ALL LINEAR DIMENSIONS ARE MILLIMETERS AND PARENTHETICALLY IN INCHES



PACKAGE 601: 32 PIN, RECTANGULAR CERAMIC LEADLESS CHIP CARRIER

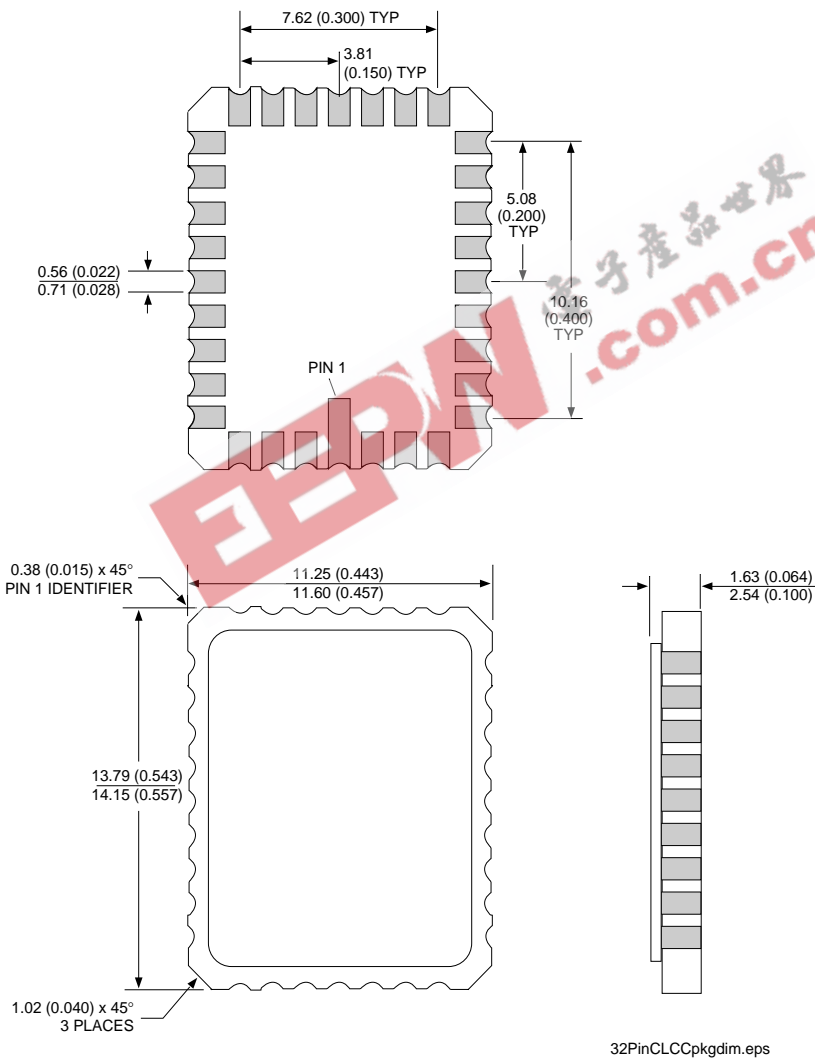

ALL LINEAR DIMENSIONS ARE MILLIMETERS AND PARENTHETICALLY IN INCHES



ORDERING INFORMATION

W M F 128K8 - XXX X X 5 X

LEAD FINISH:

Blank = Gold plated leads

A = Solder dip leads

V_{PP} PROGRAMMING VOLTAGE

5 = 5V

DEVICE GRADE:

Q = MIL-STD-883 Compliant

M = Military Screened -55°C to +125°C

I = Industrial -40°C to +85°C

C = Commercial 0°C to +70°C

PACKAGE TYPE:

DE = 32 Lead Ceramic SOJ (Package 101)

C = 32 Pin Ceramic DIP (Package 300)

FE = 32 Lead Ceramic Flatpack (Package 220)

FF = 32 Lead Formed Ceramic Flatpack (Package 221)

CL = 32 Pin rectangular Ceramic Leadless Chip Carrier (Package 601)

ACCESS TIME (ns)

ORGANIZATION, 128K x 8

Flash

MONOLITHIC

WHITE ELECTRONIC DESIGNS CORP.

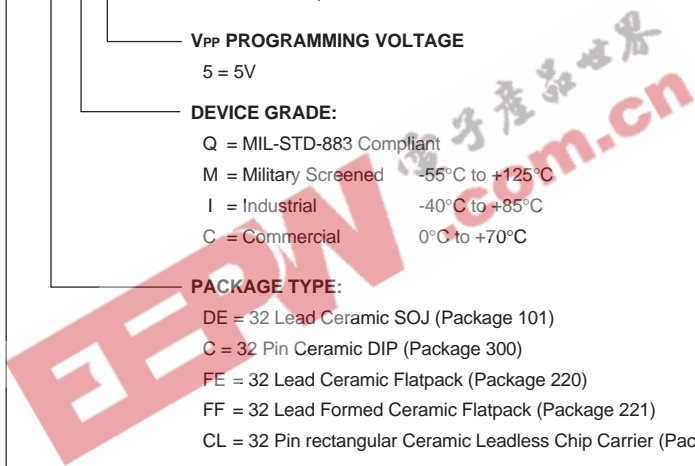



DEVICE TYPE	SECTOR SIZE	SPEED	PACKAGE	SMD NO.
128K x 8 Flash Monolithic	16KByte	150ns	32 pin DIP (C)	5962-96690 01HYX
128K x 8 Flash Monolithic	16KByte	120ns	32 pin DIP (C)	5962-96690 02HYX
128K x 8 Flash Monolithic	16KByte	90ns	32 pin DIP (C)	5962-96690 03HYX
128K x 8 Flash Monolithic	16KByte	70ns	32 pin DIP (C)	5962-96690 04HYX
128K x 8 Flash Monolithic	16KByte	60ns	32 pin DIP (C)	5962-96690 05HYX
128K x 8 Flash Monolithic	16KByte	150ns	32 lead SOJ (DE)	5962-96690 01HXX
128K x 8 Flash Monolithic	16KByte	120ns	32 lead SOJ (DE)	5962-96690 02HXX
128K x 8 Flash Monolithic	16KByte	90ns	32 lead SOJ (DE)	5962-96690 03HXX
128K x 8 Flash Monolithic	16KByte	70ns	32 lead SOJ (DE)	5962-96690 04HXX
128K x 8 Flash Monolithic	16KByte	60ns	32 lead SOJ (DE)	5962-96690 05HXX
128K x 8 Flash Monolithic	16KByte	150ns	32 lead Flatpack (FE)	5962-96690 01HTX
128K x 8 Flash Monolithic	16KByte	120ns	32 lead Flatpack (FE)	5962-96690 02HTX
128K x 8 Flash Monolithic	16KByte	90ns	32 lead Flatpack (FE)	5962-96690 03HTX
128K x 8 Flash Monolithic	16KByte	70ns	32 lead Flatpack (FE)	5962-96690 04HTX
128K x 8 Flash Monolithic	16KByte	60ns	32 lead Flatpack (FE)	5962-96690 05HTX
128K x 8 Flash Monolithic	16KByte	150ns	32 lead Formed Flatpack (FF)	5962-96690 01HUX
128K x 8 Flash Monolithic	16KByte	120ns	32 lead Formed Flatpack (FF)	5962-96690 02HUX
128K x 8 Flash Monolithic	16KByte	90ns	32 lead Formed Flatpack (FF)	5962-96690 03HUX
128K x 8 Flash Monolithic	16KByte	70ns	32 lead Formed Flatpack (FF)	5962-96690 04HUX
128K x 8 Flash Monolithic	16KByte	60ns	32 lead Formed Flatpack (FF)	5962-96690 05HUX