

Stereo CODEC With Speaker Driver and Video Buffer

DESCRIPTION

The WM8980 is a low power, high quality stereo codec with integrated video buffer designed for portable applications such as Digital still camera or Digital Camcorder.

The device integrates preamps for stereo differential mics, and includes drivers for speakers, headphone and differential or stereo line output. External component requirements are reduced as no separate microphone or headphone amplifiers are required.

An integrated video buffer is provided which has programmable gain from 0-6dB, sync-tip clamp and a 3rd order input low pass filter for signal re-construction.

Advanced on-chip digital signal processing includes a 5-band equaliser, a mixed signal Automatic Level Control for the microphone or line input through the ADC as well as a purely digital limiter function for record or playback. Additional digital filtering options are available in the ADC path, to cater for application filtering such as 'wind noise reduction'.

The WM8980 CODEC can operate as a master or a slave. An internal PLL can generate all required audio clocks for the Codec from common reference clock frequencies, such as 12MHz and 13MHz.

The WM8980 operates at analogue supply voltages from 2.5V to 3.3V, although the digital core can operate at voltages down to 1.62V to save power. The speaker outputs and OUT3/4 line outputs can run from a 5V supply if increased output power is required. Individual sections of the chip can also be powered down under software control.

FEATURES

- **Stereo Codec:**
- DAC SNR 98dB, THD -84dB ('A' weighted @ 48kHz)
- ADC SNR 90dB, THD -80dB ('A' weighted @ 48kHz)
- On-chip Headphone Driver with 'capless' option
 - 40mW output power into 16Ω / 3.3V SPKVDD
- 0.9W output power into 8Ω BTL speaker / 5V SPKVDD
 - Capable of driving piezo speakers
 - Stereo speaker drive configuration
- **Mic Preamps:**
- Stereo Differential or mono microphone Interfaces
 - Programmable preamp gain
 - Pseudo differential inputs with common mode rejection
 - Programmable ALC / Noise Gate in ADC path
- Low-noise bias supplied for electret microphones
- **Other features:**
- Integrated 0-6dB video buffer with LPF filter and clamp.
- Enhanced 3-D function for improved stereo separation
- Digital playback limiter
- 5-band Equaliser (record or playback)
- Programmable ADC High Pass Filter (wind noise reduction)
- Programmable ADC Notch Filter
- Aux inputs for stereo analog input signals or 'beep'
- On-chip PLL supporting 12, 13, 19.2MHz and other clocks
- Low power, low voltage
 - 2.5V to 3.6V (digital core: 1.62V to 3.6V)
 - power consumption <30mW all-on with 2.5V supplies
- 6x6mm 40-pin QFN package

APPLICATIONS

- Stereo Camcorder or DSC

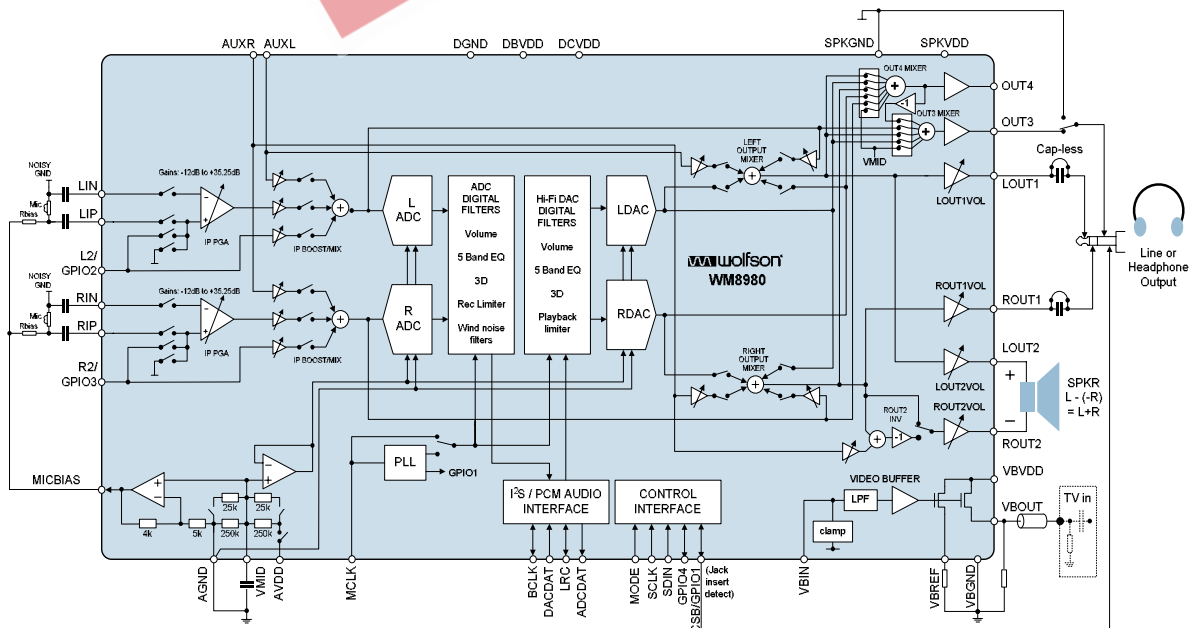
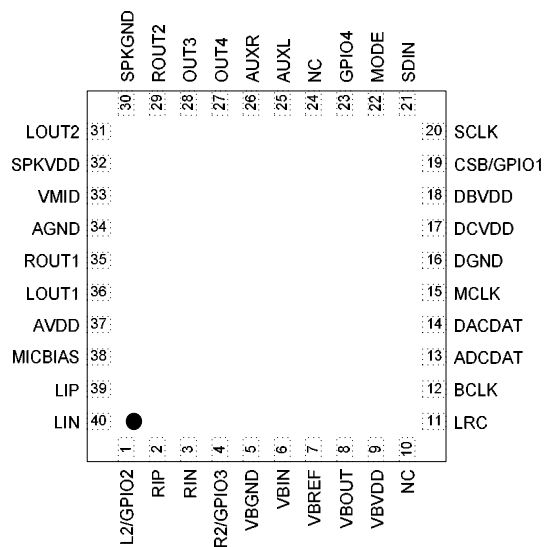

TABLE OF CONTENTS

DESCRIPTION	1
FEATURES	1
APPLICATIONS	1
TABLE OF CONTENTS	2
PIN CONFIGURATION	3
ORDERING INFORMATION	3
PIN DESCRIPTION	4
ABSOLUTE MAXIMUM RATINGS	5
RECOMMENDED OPERATING CONDITIONS	5
ELECTRICAL CHARACTERISTICS	6
TERMINOLOGY	9
POWER CONSUMPTION	10
SIGNAL TIMING REQUIREMENTS	11
SYSTEM CLOCK TIMING	11
AUDIO INTERFACE TIMING – MASTER MODE	11
AUDIO INTERFACE TIMING – SLAVE MODE.....	12
CONTROL INTERFACE TIMING – 3-WIRE MODE	13
CONTROL INTERFACE TIMING – 2-WIRE MODE	14
DEVICE DESCRIPTION	15
INTRODUCTION	15
INPUT SIGNAL PATH	17
ANALOGUE TO DIGITAL CONVERTER (ADC).....	23
INPUT LIMITER / AUTOMATIC LEVEL CONTROL (ALC)	27
OUTPUT SIGNAL PATH	31
3D STEREO ENHANCEMENT	37
ANALOGUE OUTPUTS.....	38
VIDEO BUFFER.....	53
DIGITAL AUDIO INTERFACES.....	54
AUDIO SAMPLE RATES.....	61
MASTER CLOCK AND PHASE LOCKED LOOP (PLL)	61
GENERAL PURPOSE INPUT/OUTPUT	63
OUTPUT SWITCHING (JACK DETECT).....	64
CONTROL INTERFACE.....	66
RESETTING THE CHIP	67
POWER SUPPLIES	67
POWER MANAGEMENT	68
REGISTER MAP	70
DIGITAL FILTER CHARACTERISTICS	72
TERMINOLOGY	72
DAC FILTER RESPONSES.....	73
ADC FILTER RESPONSES.....	73
HIGHPASS FILTER.....	74
5-BAND EQUALISER.....	75
APPLICATION INFORMATION	79
RECOMMENDED EXTERNAL COMPONENTS	79
PACKAGE DIAGRAM	80
IMPORTANT NOTICE	81
ADDRESS:	81

PIN CONFIGURATION



ORDERING INFORMATION

ORDER CODE	TEMPERATURE RANGE	PACKAGE	MOISTURE SENSITIVITY LEVEL	PEAK SOLDERING TEMPERATURE
WM8980GEFL/V	-25°C to +85°C	40-pin QFN (6 x 6 mm) (lead free)	MSL3	260°C
WM8980GEFL/RV	-25°C to +85°C	40-pin QFN (6 x 6 mm) (lead free, tape and reel)	MSL3	260°C

Note:

Reel quantity = 3,500

PIN DESCRIPTION

PIN	NAME	TYPE	DESCRIPTION
1	L2/GPIO2	Analogue input	Left channel line input/secondary mic pre-amp positive input/GPIO pin
2	RIP	Analogue input	Right Mic Pre-amp positive input
3	RIN	Analogue input	Right Mic Pre-amp negative input
4	R2/GPIO3	Analogue input	Right channel line input/secondary mic pre-amp positive input/GPIO pin
5	VBGND	Supply	Video buffer ground pin
6	VBIN	Analogue input	Video buffer signal input
7	VBREF	Analogue output	Video buffer reference resistor pin
8	VBOUT	Analogue output	Video buffer output
9	VBVDD	Supply	Video buffer analogue supply
10	NC	Not internally connected	
11	LRC	Digital Input / Output	DAC and ADC Sample Rate Clock
12	BCLK	Digital Input / Output	Digital Audio Port Clock
13	ADCDAT	Digital Output	ADC Digital Audio Data Output
14	DACDAT	Digital Input	DAC Digital Audio Data Input
15	MCLK	Digital Input	Master Clock Input
16	DGND	Supply	Digital ground
17	DCVDD	Supply	Digital core logic supply
18	DBVDD	Supply	Digital buffer (I/O) supply
19	CSB/GPIO1	Digital Input / Output	3-Wire MPU Chip Select / General purpose input/output 1
20	SCLK	Digital Input	3-Wire MPU Clock Input / 2-Wire MPU Clock Input
21	SDIN	Digital Input / Output	3-Wire MPU Data Input / 2-Wire MPU Data Input
22	MODE	Digital Input	Control Interface Selection
23	GPIO4	Digital input/output	General purpose input/output 4
24	NC	Not internally connected	
25	AUXL	Analogue input	Left Auxillary input
26	AUXR	Analogue input	Right Auxillary input
27	OUT4	Analogue Output	Buffered midrail Headphone pseudo-ground, or Right line output or MONO mix output
28	OUT3	Analogue Output	Buffered midrail Headphone pseudo-ground, or Left line output
29	ROUT2	Analogue Output	Second right output, or BTL speaker driver negative output
30	SPKGND	Supply	Speaker ground (feeds speaker amp and OUT3/OUT4)
31	LOUT2	Analogue Output	Second left output, or BTL speaker driver positive output
32	SPKVDD	Supply	Speaker supply (feed speaker amp only)
33	VMID	Reference	Decoupling for ADC and DAC reference voltage
34	AGND	Supply	Analogue ground (feeds ADC and DAC)
35	ROUT1	Analogue Output	Headphone Output Right
36	LOUT1	Analogue Output	Headphone Output Left
37	AVDD	Supply	Analogue supply (feeds ADC and DAC)
38	MICBIAS	Analogue Output	Microphone Bias
39	LIP	Analogue input	Left Mic Pre-amp positive input
40	LIN	Analogue input	Left Mic Pre-amp negative input

Note:

It is recommended that the QFN ground paddle should be connected to analogue ground on the application PCB.

ABSOLUTE MAXIMUM RATINGS

Absolute Maximum Ratings are stress ratings only. Permanent damage to the device may be caused by continuously operating at or beyond these limits. Device functional operating limits and guaranteed performance specifications are given under Electrical Characteristics at the test conditions specified.



ESD Sensitive Device. This device is manufactured on a CMOS process. It is therefore generically susceptible to damage from excessive static voltages. Proper ESD precautions must be taken during handling and storage of this device.

Wolfson tests its package types according to IPC/JEDEC J-STD-020B for Moisture Sensitivity to determine acceptable storage conditions prior to surface mount assembly. These levels are:

MSL1 = unlimited floor life at <30°C / 85% Relative Humidity. Not normally stored in moisture barrier bag.

MSL2 = out of bag storage for 1 year at <30°C / 60% Relative Humidity. Supplied in moisture barrier bag.

MSL3 = out of bag storage for 168 hours at <30°C / 60% Relative Humidity. Supplied in moisture barrier bag.

The Moisture Sensitivity Level for each package type is specified in Ordering Information.

CONDITION	MIN	MAX
DBVDD, DCVDD, AVDD, VBVD supply voltages	-0.3V	+3.63V
SPKVDD supply voltage	-0.3V	+7V
Voltage range digital inputs	DGND -0.3V	DVDD +0.3V
Voltage range analogue inputs	AGND -0.3V	AVDD +0.3V
Operating temperature range, T _A	-25°C	+85°C
Storage temperature after soldering	-65°C	+150°C

Notes

1. Analogue and digital grounds must always be within 0.3V of each other.
2. All digital and analogue supplies are completely independent from each other.

RECOMMENDED OPERATING CONDITIONS

PARAMETER	SYMBOL	TEST CONDITIONS	MIN	TYP	MAX	UNIT
Digital supply range (Core)	DCVDD		1.62		3.6	V
Digital supply range (Buffer)	DBVDD		1.8		3.6	V
Analogue core supply range	AVDD		2.5		3.6	V
Video buffer supply range	VBVDD		2.5		3.6	V
Analogue output supply range	SPKVDD		2.5		5.5	V
Ground	DGND,AGND, SPKGND,VBGND			0		V

ELECTRICAL CHARACTERISTICS

Test Conditions

DCVDD=1.8V, AVDD=DBVDD=SPKVDD=VBVDD = 3.3V, T_A = +25°C, 1kHz signal, fs = 48kHz, 24-bit audio data unless otherwise stated.

PARAMETER	SYMBOL	TEST CONDITIONS	MIN	TYP	MAX	UNIT
Microphone Preamp Inputs (LIP, LIN, RIP, RIN, L2, R2)						
Full-scale Input Signal Level – note this changes with AVDD (Note 1)	V _{INFS}	PGABOOST = 0dB INPPGAVOL = 0dB		1.0 0		V _{rms} dBV
Mic PGA equivalent input noise	At 35.25dB gain			TBD		µV
Input resistance	R _{MICIN}	Gain set to 35.25dB		1.6		kΩ
	R _{MICIN}	Gain set to 0dB		47		kΩ
	R _{MICIN}	Gain set to -12dB		75		kΩ
	R _{MICIP}	MICP2INPPGA = 1		94		kΩ
	R _{MICIP}	MICP2INPPGA = 0		TBD		kΩ
	C _{MICIN}			10		pF
Recommended coupling cap	C _{COUP}			220		pF
MIC Programmable Gain Amplifier (PGA)						
Programmable Gain			-12		35.25	dB
Programmable Gain Step Size		Guaranteed monotonic		0.75		dB
Mute Attenuation				TBD		dB
Selectable Input Gain Boost (0/+20dB)						
Gain Boost on PGA input		Boost disabled		0		dB
		Boost enabled		20		dB
Gain range from AUXL/R or L/R2 input to boost/mixer			-12		+6	dB
Gain step size to boost/mixer				3		dB
Auxiliary Analogue Inputs (AUXL, AUXR)						
Full-scale Input Signal Level (0dB) – note this changes with AVDD	V _{INFS}			AVDD/3.3 0		V _{rms} dBV
Input Resistance (Note 2)	R _{AUXINLMIN}	Left Input boost and mixer enabled, at max gain		4.3		kΩ
	R _{AUXINLTYP}	Left Input boost and mixer enabled, at 0dB gain		8.6		kΩ
	R _{AUXINLMAX}	Left Input boost and mixer enabled, at min gain		39.1		kΩ
	R _{AUXINRMIN}	Right Input boost, mixer and beep enabled, at max gain		3		kΩ
	R _{AUXINRTYP}	Right Input boost, mixer and beep enabled, at 0dB gain		6		kΩ
	R _{AUXINRMAX}	Right Input boost, mixer and beep enabled, at min gain		29		kΩ
Input Capacitance	C _{MICIN}			10		pF

Test Conditions

DCVDD=1.8V, AVDD=DBVDD=SPKVDD=VBVDD = 3.3V, T_A = +25°C, 1kHz signal, fs = 48kHz, 24-bit audio data unless otherwise stated.

PARAMETER	SYMBOL	TEST CONDITIONS	MIN	TYP	MAX	UNIT
Automatic Level Control (ALC)						
Target Record Level			-28.5		-6	dB
Programmable gain			-12		35.25	
Gain Hold Time (Note 3,5)	t _{HOLD}	MCLK = 12.288MHz (Note 3)	0, 2.67, 5.33, 10.67, ... , 43691 (time doubles with each step)			ms
Gain Ramp-Up (Decay) Time (Note 4,5)	t _{DCY}	ALCMODE=0 (ALC), MCLK=12.288MHz (Note 3)	3.3, 6.6, 13.1, ... , 3360 (time doubles with each step)			ms
		ALCMODE=1 (limiter), MCLK=12.288MHz (Note 3)	0.73, 1.45, 2.91, ... , 744 (time doubles with each step)			
Gain Ramp-Down (Attack) Time (Note 4,5)	t _{ATK}	ALCMODE=0 (ALC), MCLK=12.288MHz (Note 3)	0.83, 1.66, 3.33, ... , 852 (time doubles with each step)			ms
		ALCMODE=1 (limiter), MCLK=12.288MHz (Note 3)	0.18, 0.36, 0.73, ... , 186 (time doubles with each step)			
Mute Attenuation				TBD		dB
Analogue to Digital Converter (ADC)						
Signal to Noise Ratio (Note 6,7)		A-weighted, 0dB gain		90		dB
Total Harmonic Distortion (Note 8)		full-scale, 0dB gain		-80		dB
Channel Separation (Note 9)		1kHz input signal		100		dB
Digital to Analogue Converter (DAC) to Line-Out (LOUT1, ROUT1 with 10kΩ / 50pF load)						
Full-scale output		PGA gains set to 0dB, OUT34BOOST=0		AVDD/3.3		Vrms
		PGA gains set to 0dB, OUT34BOOST=1		1.5x (AVDD/3.3)		
Signal to Noise Ratio (Note 6, 7)	SNR	A-weighted	TBD	98		dB
Total Harmonic Distortion (Note 8)	THD	R _L = 10kΩ full-scale signal		-84		dB
Channel Separation (Note 9)		1kHz signal	80	100		dB
Output Mixers (LMX1, RMX1)						
PGA gain range into mixer			-15	0	+6	dB
PGA gain step into mixer				3		dB
Analogue Outputs (LOUT1, ROUT1, LOUT2, ROUT2)						
Programmable Gain range			-57	0	+6	dB
Programmable Gain step size		Monotonic		1		dB
Mute attenuation		1kHz, full scale signal		85		dB
Headphone Output (LOUT1, ROUT1 with 32Ω load)						
0dB full scale output voltage				AVDD/3.3		Vrms
Signal to Noise Ratio	SNR	A-weighted	TBD	93		dB
Total Harmonic Distortion	THD	R _L = 16Ω, Po=20mW AVDD=3.3V		0.008 -81		% dB
		R _L = 32 Ω, Po=20mW AVDD=3.3V		0.007 - 83		% dB

Test Conditions

DCVDD=1.8V, AVDD=DBVDD=SPKVDD=VBVDD = 3.3V, T_A = +25°C, 1kHz signal, fs = 48kHz, 24-bit audio data unless otherwise stated.

PARAMETER	SYMBOL	TEST CONDITIONS	MIN	TYP	MAX	UNIT
Speaker Output (LOUT2, ROUT2 with 8Ω bridge tied load, INVROUT2=1)						
Full scale output voltage, 0dB gain. (Note 10)		SPKRBOOST=0		SPKVDD/3.3		V _{rms}
		SPKRBOOST=1		(SPKVDD/3.3)*1.5		
Output Power	P _O	Output power is very closely correlated with THD; see below				
Total Harmonic Distortion	THD	P _O =180mW, R _L = 8Ω, SPKVDD=3.3V		0.3 -50		% dB
		P _O =400mW, R _L = 8Ω, SPKVDD=3.3V		1.0 -40		% dB
		P _O =360mW, R _L = 8Ω, SPKVDD=5V		0.3 -50		% dB
		P _O =800mW, R _L = 8Ω, SPKVDD=5V		1 -40		% dB
Signal to Noise Ratio	SNR	SPKVDD=3.3V, R _L = 8Ω		90		dB
		SPKVDD=5V, R _L = 8Ω		90		dB
Power Supply Rejection Ratio				50		dB
OUT3/OUT4 outputs (with 10kΩ / 50pF load)						
Full-scale output voltage, 0dB gain (Note 10)		OUT3BOOST=0/ OUT4BOOST=0		SPKVDD/3.3		V _{rms}
		OUT3BOOST=1/ OUT4BOOST=1		(SPKVDD/3.3)*1.5		V _{rms}
Signal to Noise Ratio (Note 6,7)	SNR	A-weighted	TBD	98		dB
Total Harmonic Distortion (Note 8)	THD	R _L = 10 kΩ full-scale signal		-84		dB
Channel Separation (Note 9)		1kHz signal	80	100		dB
Microphone Bias						
Bias Voltage	V _{MICBIAS}	MBVSEL=0		0.9*AVDD		V
		MBVSEL=1		0.75*AVDD		V
Bias Current Source	I _{MICBIAS}				3	mA
Output Noise Voltage	V _n	1K to 20kHz		15		nV/√Hz
Video Buffer						
Low pass filter order				3 rd order		
LPF -3dB cutoff				10		MHz
LPF gain flat to within 0.1dB				5.3		MHz
Maximum output voltage swing	V _{om}	f=100kHz, THD=1%		1.25		V _{p-p}
Programmable Voltage Gain	A _v		0		6	dB
Differential gain	DG	V _{in} =1V _{p-p}		1		%
Differential phase	DP	V _{in} =1V _{p-p}		1		Deg
Signal to Noise Ratio	VSNR			+60		dB
Digital Input / Output						
Input HIGH Level	V _{IH}		0.7×DBVDD			V
Input LOW Level	V _{IL}				0.3×DBVDD	V
Output HIGH Level	V _{OH}	I _{OL} =1mA	0.9×DBVDD			V
Output LOW Level	V _{OL}	I _{OH} =1mA			0.1×DBVDD	V
Input capacitance				TBD		pF
Input leakage				TBD		pA

TERMINOLOGY

1. Input level to RIP and LIP in pseudo-differential configurations is limited to a maximum of -3dB or THD+N performance will be reduced.
2. Note when BEEP path is not enabled then AUXL and AUXR have the same input impedances.
3. Hold Time is the length of time between a signal detected being too quiet and beginning to ramp up the gain. It does not apply to ramping down the gain when the signal is too loud, which happens without a delay.
4. Ramp-up and Ramp-Down times are defined as the time it takes for the PGA to sweep across 90% of its gain range.
5. All hold, ramp-up and ramp-down times scale proportionally with MCLK
6. Signal-to-noise ratio (dB) – SNR is a measure of the difference in level between the full scale output and the output with no signal applied. (No Auto-zero or Automute function is employed in achieving these results).
7. Dynamic range (dB) – DR is a measure of the difference between the highest and lowest portions of a signal. Normally a THD+N measurement at 60dB below full scale. The measured signal is then corrected by adding the 60dB to it. (e.g. THD+N @ -60dB= -32dB, DR= 92dB).
8. THD+N (dB) – THD+N is a ratio, of the rms values, of (Noise + Distortion)/Signal.
9. Channel Separation (dB) – Also known as Cross-Talk. This is a measure of the amount one channel is isolated from the other. Normally measured by sending a full scale signal down one channel and measuring the other.
10. The maximum output voltage can be limited by the speaker power supply. If OUT3BOOST, OUT4BOOST or SPKRBOOST is set then SPKVDD should be 1.5xAVDD to prevent clipping taking place in the output stage (when PGA gains are set to 0dB).

EEPW 电子產品世界
.com.cn

POWER CONSUMPTION

Estimated current consumption for typical scenarios are shown below.

For more information on current consumption of individual blocks, see "Estimated Supply Currents" section.

Unless otherwise specified, all supply voltages are 3.3V.

MODE	AVDD	DCVDD	VBVDD	UNITS
Off	0	0	0	mA
Sleep (VREF maintained)	0.1	0	0	mA
Stereo Record (8kHz, PLL enabled)	8.1	0.8	0	mA
Stereo HP Playback (44.1kHz, PLL enabled)	6.6	4.3	0	mA
Stereo HP Playback (44.1kHz, PLL enabled, Video Buffer enabled)	6.6	4.3	1.0	mA

Table 1 Power Consumption

Notes:

1. DBVDD Supply current is not shown, as this is determined by loading on the digital I/O pins.

EEPW 电子产品世界 .com.cn

SIGNAL TIMING REQUIREMENTS

SYSTEM CLOCK TIMING

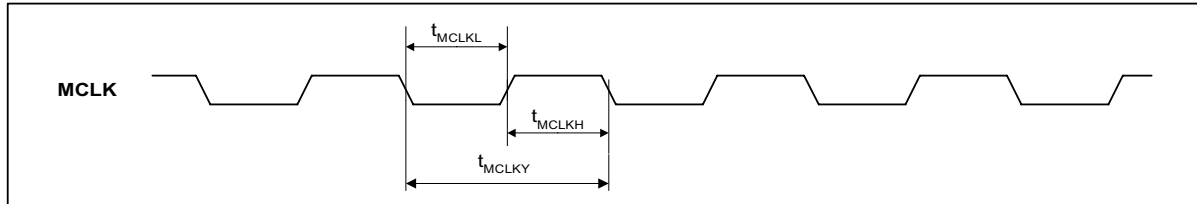

Figure 1 System Clock Timing Requirements

Test Conditions

DCVDD=1.8V, DBVDD=AVDD=SPKVDD=3.3V, DGND=AGND=SPKGND=0V, $T_A = +25^\circ\text{C}$, Slave Mode $f_s = 48\text{kHz}$, MCLK = 256fs, 24-bit data, unless otherwise stated.

PARAMETER	SYMBOL	MIN	TYP	MAX	UNIT
System Clock Timing Information					
MCLK System clock cycle time	T_{MCLKY}	Tbd			ns
MCLK duty cycle	T_{MCLKDS}	60:40		40:60	

AUDIO INTERFACE TIMING – MASTER MODE

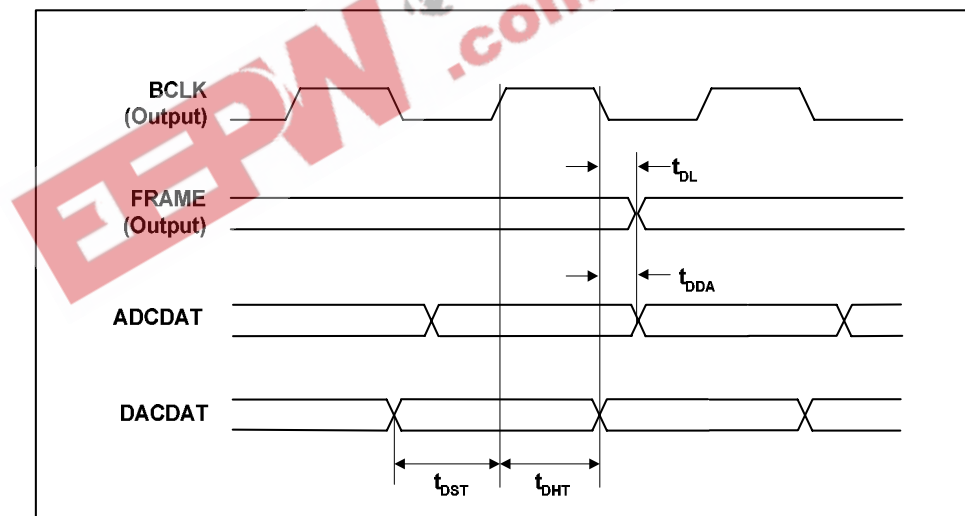

Figure 2 Digital Audio Data Timing – Master Mode (see Control Interface)

Test Conditions

DCVDD=1.8V, DBVDD=AVDD=SPKVDD=3.3V, DGND=AGND=SPKGND=0V, $T_A=+25^{\circ}\text{C}$, Slave Mode, $f_s=48\text{kHz}$, MCLK=256fs, 24-bit data, unless otherwise stated.

PARAMETER	SYMBOL	MIN	TYP	MAX	UNIT
Audio Data Input Timing Information					
FRAME propagation delay from BCLK falling edge	t_{DL}			10	ns
ADCDAT propagation delay from BCLK falling edge	t_{DDA}			10	ns
DACDAT setup time to BCLK rising edge	t_{DST}	10			ns
DACDAT hold time from BCLK rising edge	t_{DHT}	10			ns

AUDIO INTERFACE TIMING – SLAVE MODE

Figure 3 Digital Audio Data Timing – Slave Mode

Test Conditions

DCVDD=1.8V, DBVDD=AVDD=SPKVDD=3.3V, DGND=AGND=SPKGND=0V, $T_A=+25^{\circ}\text{C}$, Slave Mode, $f_s=48\text{kHz}$, MCLK= 256fs, 24-bit data, unless otherwise stated.

PARAMETER	SYMBOL	MIN	TYP	MAX	UNIT
Audio Data Input Timing Information					
BCLK cycle time	t_{BCY}	50			ns
BCLK pulse width high	t_{BCH}	20			ns
BCLK pulse width low	t_{BCL}	20			ns
FRAME set-up time to BCLK rising edge	t_{LRSU}	10			ns
FRAME hold time from BCLK rising edge	t_{LRH}	10			ns
DACDAT hold time from BCLK rising edge	t_{DH}	10			ns
ADCDAT propagation delay from BCLK falling edge	t_{DD}			10	ns

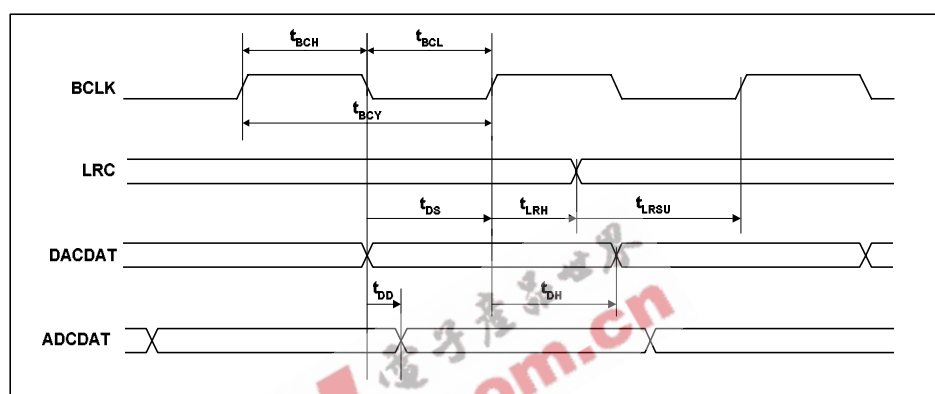
Note:

BCLK period should always be greater than or equal to MCLK period.

CONTROL INTERFACE TIMING – 3-WIRE MODE

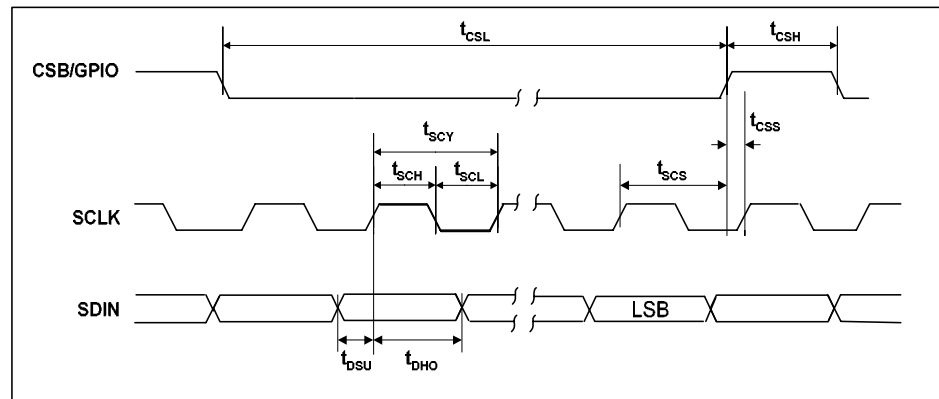

Figure 4 Control Interface Timing – 3-Wire Serial Control Mode

Test Conditions

DCVDD = 1.8V, DBVDD = AVDD = SPKVDD = 3.3V, DGND = AGND = SPKGND = 0V, $T_A = +25^\circ\text{C}$, Slave Mode, $f_s = 48\text{kHz}$, MCLK = 256fs, 24-bit data, unless otherwise stated.

PARAMETER	SYMBOL	MIN	TYP	MAX	UNIT
Program Register Input Information					
SCLK rising edge to CSB rising edge	t_{SCS}	80			ns
SCLK pulse cycle time	t_{SCY}	200			ns
SCLK pulse width low	t_{SCL}	80			ns
SCLK pulse width high	t_{SCH}	80			ns
SDIN to SCLK set-up time	t_{DSU}	40			ns
SCLK to SDIN hold time	t_{DHO}	40			ns
CSB pulse width low	t_{CSL}	40			ns
CSB pulse width high	t_{CSH}	40			ns
CSB rising to SCLK rising	t_{CSS}	40			ns
Pulse width of spikes that will be suppressed	t_{ps}	0		5	ns

CONTROL INTERFACE TIMING – 2-WIRE MODE

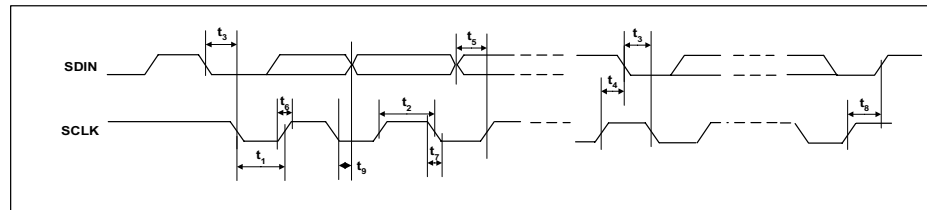

Figure 5 Control Interface Timing – 2-Wire Serial Control Mode

Test Conditions

DCVDD=1.8V, DBVDD=AVDD=SPKVDD=3.3V, DGND=AGND=SPKGND=0V, $T_A=+25^{\circ}\text{C}$, Slave Mode, $f_s=48\text{kHz}$, MCLK = 256fs, 24-bit data, unless otherwise stated.

PARAMETER	SYMBOL	MIN	TYP	MAX	UNIT
Program Register Input Information					
SCLK Frequency		0		400	kHz
SCLK Low Pulse-Width	t_1	1.3			us
SCLK High Pulse-Width	t_2	600			ns
Hold Time (Start Condition)	t_3	600			ns
Setup Time (Start Condition)	t_4	600			ns
Data Setup Time	t_5	100			ns
SDIN, SCLK Rise Time	t_6			300	ns
SDIN, SCLK Fall Time	t_7			300	ns
Setup Time (Stop Condition)	t_8	600			ns
Data Hold Time	t_9			900	ns
Pulse width of spikes that will be suppressed	t_{ps}	0		5	ns

DEVICE DESCRIPTION

INTRODUCTION

The WM8980 is a low power audio codec combining a high quality stereo audio DAC and ADC, with flexible line and microphone input and output processing. Applications for this device include stereo digital camcorders, and digital still cameras with either mono or stereo, audio and video, record and playback capability. The integrated video buffer makes the device suitable for driving both audio and video signals directly to a television or VCR.

FEATURES

The chip offers great flexibility in use, and so can support many different modes of operation as follows:

MICROPHONE INPUTS

Two pairs of stereo microphone inputs are provided, allowing for a pair of stereo microphones to be pseudo-differentially connected, with user defined gain using internal resistors. The provision of the common mode input pin for each stereo input allows for rejection of common mode noise on the microphone inputs (level depends on gain setting chosen). A microphone bias is output from the chip which can be used to bias both microphones. The signal routing can be configured to allow manual adjustment of mic levels, or indeed to allow the ALC loop to control the level of mic signal that is transmitted.

Total gain through the microphone paths of up to +55.25dB can be selected.

PGA AND ALC OPERATION

A programmable gain amplifier is provided in the input path to the ADC. This may be used manually or in conjunction with a mixed analogue/digital automatic level control (ALC) which keeps the recording volume constant.

LINE INPUTS (AUXL, AUXR)

The inputs, AUXL and AUXR, can be used as a stereo line input or as an input for warning tones (or 'beeps') etc. These inputs can be summed into the record paths, along with the microphone preamp outputs, so allowing for mixing of audio with 'backing music' etc as required.

ADC

The stereo ADC uses a multi-bit high-order oversampling architecture to deliver optimum performance with low power consumption.

HI-FI DAC

The hi-fi DAC provides high quality audio playback suitable for all portable audio hi-fi type applications, including MP3 players and portable disc players of all types.

OUTPUT MIXERS

Flexible mixing is provided on the outputs of the device. A stereo mixer is provided for the stereo headphone or line outputs, LOUT1/ROUT1, and additional summers on the OUT3/OUT4 outputs allow for an optional differential or stereo line output on these pins. Gain adjustment PGAs are provided for the LOUT1/ROUT1 and LOUT2/ROUT2 outputs, and signal switching is provided to allow for all possible signal combinations. The output buffers can be configured in several ways, allowing support of up to three sets of external transducers; ie stereo headphone, BTL speaker, and BTL earpiece may be connected simultaneously. Thermal implications should be considered before simultaneous full power operation of all outputs is attempted.

Alternatively, if a speaker output is not required, the LOUT2 and ROUT2 pins might be used as a stereo headphone driver, (disable output invert buffer on ROUT2). In that case two sets of headphones might be driven, or the LOUT2 and ROUT2 pins used as a line output driver.

OUT3 and OUT4 can be configured to provide an additional stereo lineout from the output of the DACs, the mixers or the input microphone boost stages. Alternatively OUT4 can be configured as a mono mix of left and right DACs or mixers, or simply a buffered version of the chip midrail reference voltage. OUT3 can also be configured as a buffered VMID output. This voltage may then be used as a headphone 'pseudo ground' allowing removal of the large AC coupling capacitors often used in the output path.

AUDIO INTERFACES

The WM8980 has a standard audio interface, to support the transmission of stereo data to and from the chip. This interface is a 3 wire standard audio interface which supports a number of audio data formats including I2S, DSP/PCM Mode (a burst mode in which LRC sync plus 2 data packed words are transmitted), MSB-First, left justified and MSB-First, right justified, and can operate in master or slave modes.

CONTROL INTERFACES

To allow full software control over all its features, the WM8980 offers a choice of 2 or 3 wire MPU control interface. It is fully compatible and an ideal partner for a wide range of industry standard microprocessors, controllers and DSPs.

Selection between the modes is via the MODE pin. In 2 wire mode the address of the device is fixed as 0011010.

CLOCKING SCHEMES

WM8980 offers the normal audio DAC clocking scheme operation, where 256fs MCLK is provided to the DAC and ADC.

A PLL is included which may be used to generate these clocks in the event that they are not available from the system controller. This PLL uses an input clock, typically the 12MHz USB or iLink clock, to generate high quality audio clocks. If this PLL is not required for generation of these clocks, it can be reconfigured to generate alternative clocks which may then be output on the GPIO pins and used elsewhere in the system.

VIDEO BUFFER

The WM8980 incorporates a current mode output video buffer with an input 3rd order Low Pass Filter (LPF) and clamp. The gain through this buffer can be programmed as 0dB or 6dB via the control interface. The current mode output means that the signal swing seen at the output of the buffer will be the same as that at the connection to the receiving equipment (e.g. a TV). Note that the input to the receiver should be AC coupled and terminated to 75Ω, as is standard, for best performance.

POWER CONTROL

The design of the WM8980 has given much attention to power consumption without compromising performance. It operates at very low voltages, and includes the ability to power off any unused parts of the circuitry under software control, and includes standby and power off modes.

OPERATION SCENARIOS

Flexibility in the design of the WM8980 allows for a wide range of operational scenarios, some of which are proposed below:

Stereo Camcorder; The provision of two stereo microphone preamplifiers, allows support for both internal and external microphones. All drivers for speaker, headphone and line output connections are integrated. The selectable 'application filters' after the ADC provide for features such as 'wind noise' reduction, or mechanical noise reducing filters. The integrated video buffer allows direct connection to a TV or VCR for both video and audio (via line outputs).

Stereo Digital still camera recording; Support for digital stereo video with audio recording is similar to the camcorder case. But additionally if the DSC supports MP3 playback, and perhaps recording, the ability of the ADCs to support full 48ks/s high quality stereo recording increases device flexibility. The integrated video buffer allows direct connection to the TV for display of moving and still images.

Mono Digital still camera; Full control over device functionality, and power control is provided, allowing for the case of mono DSC recording, when half of the ADC and mic and line functionality may be disabled to save power. In the mono case, the single ADC channel of audio data is sent out over both Left and Right channels of the audio interface when normal I2S type interface format is used. In the case where DSP mode is used, and mono data is being sent, only the signal channel of mono data is sent. The integrated video buffer allows direct connection to the TV for display of moving and still images.

ANALOG FM TUNER SUPPORT

An analog stereo FM tuner might be connected to the Line inputs of WM8980, and the stereo signal listened to via headphones, or recorded, simultaneously if required.

INPUT SIGNAL PATH

The WM8980 has a number of flexible analogue inputs. There are two input channels, Left and Right, each of which consists of an input PGA stage followed by a boost/mix stage which drives into the hi-fi ADC. Each input path has three input pins which can be configured in a variety of ways to accommodate single-ended, differential or dual differential microphones. There are two auxiliary input pins which can be fed into to the input boost/mix stage as well as driving into the output path. A bypass path exists from the output of the boost/mix stage into the output left/right mixers.

MICROPHONE INPUTS

The WM8980 can accommodate a variety of microphone configurations including single ended and differential inputs. The inputs to the left differential input PGA are LIN, LIP and L2. The inputs to the right differential input PGA are RIN, RIP and R2.

In single-ended microphone input configuration the microphone signal should be input to LIN or RIN and the internal NOR gate configured to clamp the non-inverting input of the input PGA to VMID.

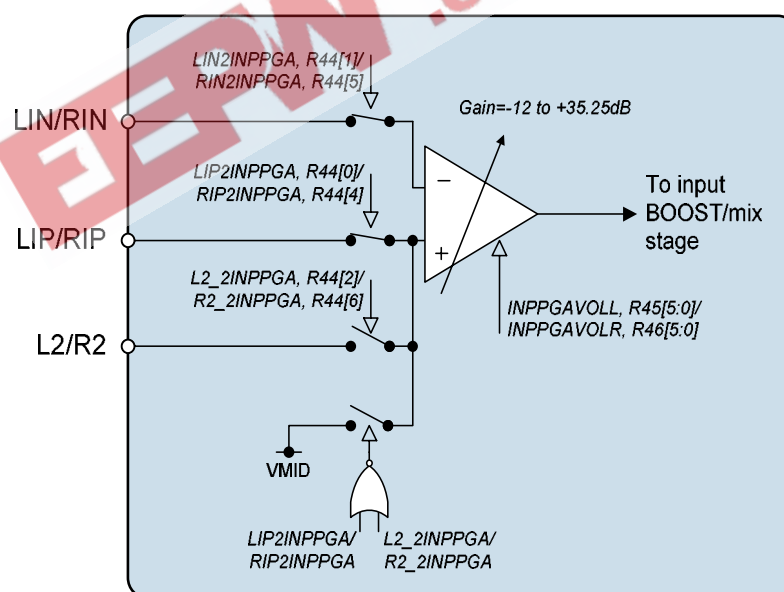

Figure 6 Microphone Input PGA Circuit

The input PGAs are enabled by the IPPGAENL/R register bits.

REGISTER ADDRESS	BIT	LABEL	DEFAULT	DESCRIPTION
R2 Power Management 2	2	INPPGAENL	0	Left channel input PGA enable 0 = disabled 1 = enabled
	3	INPPGAENR	0	Right channel input PGA enable 0 = disabled 1 = enabled

Table 2 Input PGA Enable Register Settings

REGISTER ADDRESS	BIT	LABEL	DEFAULT	DESCRIPTION
R44 Input Control	0	LIP2INPPGA	1	Connect LIP pin to left channel input PGA amplifier positive terminal. 0 = LIP not connected to input PGA 1 = input PGA amplifier positive terminal connected to LIP (constant input impedance)
	1	LIN2INPPGA	1	Connect LIN pin to left channel input PGA negative terminal. 0=LIN not connected to input PGA 1=LIN connected to input PGA amplifier negative terminal.
	2	L2_2INPPGA	0	Connect L2 pin to left channel input PGA positive terminal. 0=L2 not connected to input PGA 1=L2 connected to input PGA amplifier positive terminal (constant input impedance).
	4	RIP2INPPGA	1	Connect RIP pin to right channel input PGA amplifier positive terminal. 0 = RIP not connected to input PGA 1 = right channel input PGA amplifier positive terminal connected to RIP (constant input impedance)
	5	RIN2INPPGA	1	Connect RIN pin to right channel input PGA negative terminal. 0=RIN not connected to input PGA 1=RIN connected to right channel input PGA amplifier negative terminal.
	6	R2_2INPPGA	0	Connect R2 pin to right channel input PGA positive terminal. 0=R2 not connected to input PGA 1=R2 connected to input PGA amplifier positive terminal (constant input impedance).

Table 3 Input PGA Control

INPUT PGA VOLUME CONTROLS

The input microphone PGAs have a gain range from -12dB to +35.25dB in 0.75dB steps. The gain from the LIN/RIN input to the PGA output and from the L2/R2 amplifier to the PGA output are always common and controlled by the register bits INPPGAVOLL/R[5:0]. These register bits also effect the LIP pin when LIP2INPPGA=1, the L2 pin when L2_2INPPGA=1, the RIP pin when RIP2INPPGA=1 and the R2 pin when R2_2INPPGA=1.

When the Automatic Level Control (ALC) is enabled the input PGA gains are controlled automatically and the INPPGAVOLL/R bits should not be used.

REGISTER ADDRESS	BIT	LABEL	DEFAULT	DESCRIPTION
R45 Left channel input PGA volume control	5:0	INPPGAVOLL	010000	Left channel input PGA volume 000000 = -12dB 000001 = -11.25db . 010000 = 0dB . 111111 = 35.25dB
	6	INPPGAMUTEL	0	Mute control for left channel input PGA: 0=Input PGA not muted, normal operation 1=Input PGA muted (and disconnected from the following input BOOST stage).
	7	INPPGAZCL	0	Left channel input PGA zero cross enable: 0=Update gain when gain register changes 1=Update gain on 1 st zero cross after gain register write.
	8	INPPGAUPDATE	Not latched	INPPGAVOLL and INPPGAVOLR volume do not update until a 1 is written to INPGAUPDATE (in reg 45 or 46)
R46 Right channel input PGA volume control	5:0	INPPGAVOLR	010000	Right channel input PGA volume 000000 = -12dB 000001 = -11.25db . 010000 = 0dB . 111111 = +35.25dB
	6	INPPGAMUTER	0	Mute control for right channel input PGA: 0=Input PGA not muted, normal operation 1=Input PGA muted (and disconnected from the following input BOOST stage).
	7	INPPGAZCR	0	Right channel input PGA zero cross enable: 0=Update gain when gain register changes 1=Update gain on 1 st zero cross after gain register write.
	8	INPPGAUPDATE	Not latched	INPPGAVOLL and INPPGAVOLR volume do not update until a 1 is written to INPGAUPDATE (in reg 45 or 46)
R32 ALC control 1	8:7	ALCSEL	00	ALC function select: 00=ALC off 01=ALC right only 10=ALC left only 11=ALC both on

Table 4 Input PGA Volume Control

AUXILIARY INPUTS

There are two auxiliary inputs, AUXL and AUXR which can be used for a variety of purposes such as stereo line inputs or as a 'beep' input signal to be mixed with the outputs.

The AUXL/R inputs can be used as a line input to the input BOOST stage which has gain adjust of -12dB to +6dB in 3dB steps (plus off). See the INPUT BOOST section for further details.

The AUXL/R inputs can also be mixed into the output channel mixers, with a gain of -15dB to +6dB plus off.

In addition the AUXR input can be summed into the Right speaker output path (ROUT2) with a gain adjust of -15 to +6dB. This allows a 'beep' input to be output on the speaker outputs only without affecting the headphone or lineout signals.

INPUT BOOST

Each of the stereo input PGA stages is followed by an input BOOST circuit. The input BOOST circuit has 3 selectable inputs: the input microphone PGA output, the AUX amplifier output and the L2/R2 input pin (can be used as a line input, bypassing the input PGA). These three inputs can be mixed together and have individual gain boost/adjust as shown in Figure 7.

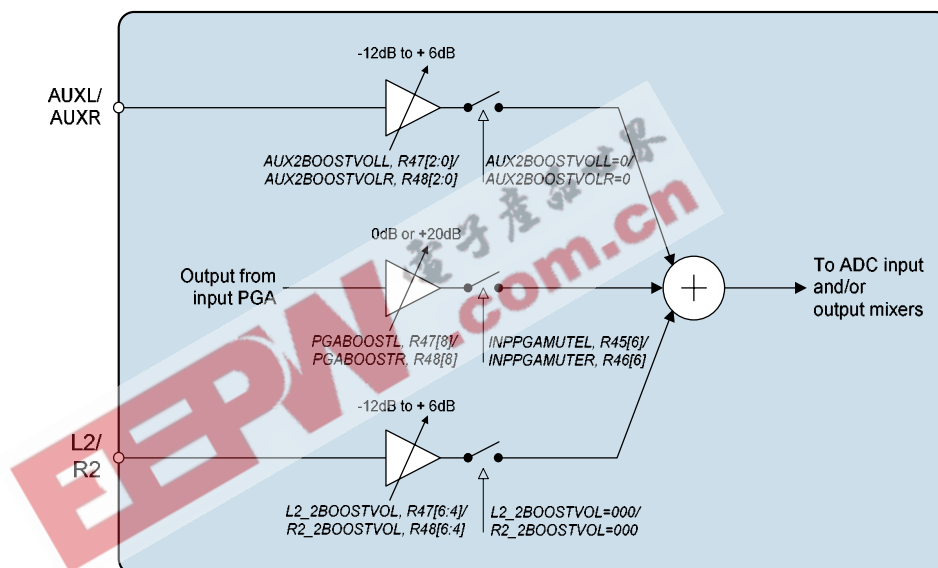

Figure 7 Input Boost Stage

The input PGA paths can have a +20dB boost (PGABOOSTL/R=1), a 0dB pass through (PGABOOSTL/R=0) or be completely isolated from the input boost circuit (INPPGAMUTEL/R=1).

REGISTER ADDRESS	BIT	LABEL	DEFAULT	DESCRIPTION
R47 Left Input BOOST control	8	PGABOOSTL	1	Boost enable for left channel input PGA: 0 = PGA output has +0dB gain through input BOOST stage. 1 = PGA output has +20dB gain through input BOOST stage.
R48 Right Input BOOST control	8	PGABOOSTR	1	Boost enable for right channel input PGA: 0 = PGA output has +0dB gain through input BOOST stage. 1 = PGA output has +20dB gain through input BOOST stage.

Table 5 Input BOOST Stage Control

The Auxilliary amplifier path to the BOOST stages is controlled by the AUXL2BOOSTVOL[2:0] and AUXR2BOOSTVOL[2:0] register bits. When AUXL2BOOSTVOL/AUXR2BOOSTVOL=000 this path is completely disconnected from the BOOST stage. Settings 001 through to 111 control the gain in 3dB steps from -12dB to +6dB.

The L2/R2 path to the BOOST stage is controlled by the LIP2BOOSTVOL[2:0] and the RIP2BOOSTVOL[2:0] register bits. When L2_2BOOSTVOL/R2_2BOOSTVOL=000 the L2/R2 input pin is completely disconnected from the BOOST stage. Settings 001 through to 111 control the gain in 3dB steps from -12dB to +6dB.

EEPW.com.cn 电子产业网

REGISTER ADDRESS	BIT	LABEL	DEFAULT	DESCRIPTION
R47 Left channel Input BOOST control	2:0	AUXL2BOOSTVOL	000	Controls the auxilliary amplifier to the left channel input boost stage: 000=Path disabled (disconnected) 001=-12dB gain through boost stage 010=-9dB gain through boost stage ... 111=+6dB gain through boost stage
	6:4	L2_2BOOSTVOL	000	Controls the L2 pin to the left channel input boost stage: 000=Path disabled (disconnected) 001=-12dB gain through boost stage 010=-9dB gain through boost stage ... 111=+6dB gain through boost stage
R48 Right channel Input BOOST control	2:0	AUXR2BOOSTVOL	000	Controls the auxilliary amplifier to the right channel input boost stage: 000=Path disabled (disconnected) 001=-12dB gain through boost stage 010=-9dB gain through boost stage ... 111=+6dB gain through boost stage
	6:4	R2_2BOOSTVOL	000	Controls the R2 pin to the right channel input boost stage: 000=Path disabled (disconnected) 001=-12dB gain through boost stage 010=-9dB gain through boost stage ... 111=+6dB gain through boost stage

Table 6 Input BOOST Stage Control

The BOOST stage is enabled under control of the BOOSTEN register bit.

REGISTER ADDRESS	BIT	LABEL	DEFAULT	DESCRIPTION
R2 Power management 2	4	BOOSTENL	0	Left channel Input BOOST enable 0 = Boost stage OFF 1 = Boost stage ON
	5	BOOSTENR	0	Right channel Input BOOST enable 0 = Boost stage OFF 1 = Boost stage ON

Table 7 Input BOOST Enable Control

MICROPHONE BIASING CIRCUIT

The MICBIAS output provides a low noise reference voltage suitable for biasing electret type microphones and the associated external resistor biasing network. Refer to the Applications Information section for recommended external components. The MICBIAS voltage can be altered via the MBVSEL register bit. When MBVSEL=0, MICBIAS=0.9*AVDD and when MBVSEL=1, MICBIAS=0.6*AVDD. The output can be enabled or disabled using the MICBEN control bit.

REGISTER ADDRESS	BIT	LABEL	DEFAULT	DESCRIPTION
R1 Power management 1	4	MICBEN	0	Microphone Bias Enable 0 = OFF (high impedance output) 1 = ON

Table 8 Microphone Bias Enable Control

REGISTER ADDRESS	BIT	LABEL	DEFAULT	DESCRIPTION
R44 Input control	8	MBVSEL	0	Microphone Bias Voltage Control 0 = 0.9 * AVDD 1 = 0.6 * AVDD

Table 9 Microphone Bias Voltage Control

The internal MICBIAS circuitry is shown in Figure 8. Note that the maximum source current capability for MICBIAS is 3mA. The external biasing resistors therefore must be large enough to limit the MICBIAS current to 3mA.

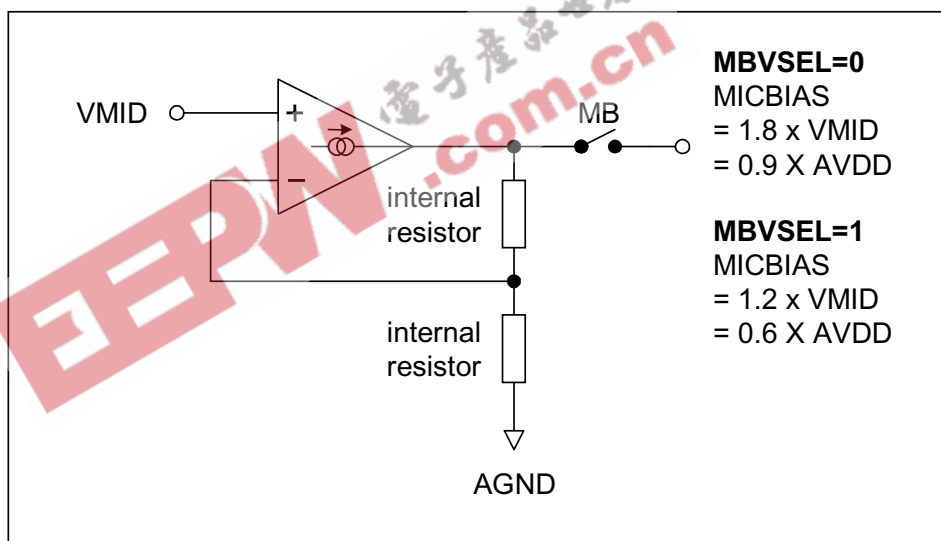

Figure 8 Microphone Bias Schematic

ANALOGUE TO DIGITAL CONVERTER (ADC)

The WM8980 uses stereo multi-bit, oversampled sigma-delta ADCs. The use of multi-bit feedback and high oversampling rates reduces the effects of jitter and high frequency noise. The ADC Full Scale input level is proportional to AVDD. With a 3.3V supply voltage, the full scale level is 1.0V_{rms}. Any voltage greater than full scale may overload the ADC and cause distortion.

ADC DIGITAL FILTERS

The ADC filters perform true 24 bit signal processing to convert the raw multi-bit oversampled data from the ADC to the correct sampling frequency to be output on the digital audio interface. The digital filter path for each ADC channel is illustrated in Figure 9.

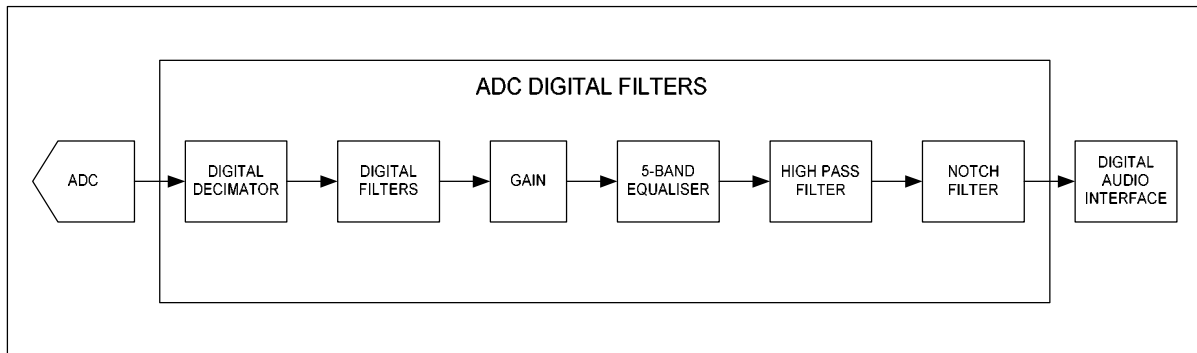

Figure 9 ADC Digital Filter Path

The ADCs are enabled by the ADCENL/R register bit.

REGISTER ADDRESS	BIT	LABEL	DEFAULT	DESCRIPTION
R2 Power management 2	0	ADCENL	0	Enable ADC left channel: 0 = ADC disabled 1 = ADC enabled
	1	ADCENR	0	Enable ADC right channel: 0 = ADC disabled 1 = ADC enabled

Table 10 ADC Enable Control

The polarity of the output signal can also be changed under software control using the ADCLPOL/ADCRPOL register bit. The oversampling rate of the ADC can be adjusted using the ADCOSR register bit. With ADCOSR=0 the oversample rate is 64x which gives lowest power operation and when ADCOSR=1 the oversample rate is 128x which gives best performance.

REGISTER ADDRESS	BIT	LABEL	DEFAULT	DESCRIPTION
R14 ADC Control	0	ADCLPOL	0	ADC left channel polarity adjust: 0=normal 1=inverted
	1	ADCRPOL	0	ADC right channel polarity adjust: 0=normal 1=inverted
	3	ADCOSR	0	ADC oversample rate select: 0=64x (lower power) 1=128x (best performance)

Table 11 ADC Control

SELECTABLE HIGH PASS FILTER

A selectable high pass filter is provided. To disable this filter set HPFEN=0. The filter has two modes controlled by HPFAPP. In Audio Mode (HPFAPP=0) the filter is first order, with a cut-off frequency of 3.7Hz. In Application Mode (HPFAPP=1) the filter is second order, with a cut-off frequency selectable via the HPFCUT register. The cut-off frequencies when HPFAPP=1 are shown in Table 13.

REGISTER ADDRESS	BIT	LABEL	DEFAULT	DESCRIPTION
R14 ADC Control	8	HPFEN	1	High Pass Filter Enable 0=disabled 1=enabled
	7	HPFAPP	0	Select audio mode or application mode 0=Audio mode (1 st order, $f_c = \sim 3.7\text{Hz}$) 1=Application mode (2 nd order, $f_c = \text{HPFCUT}$)
	6:4	HPFCUT	000	Application mode cut-off frequency See Table 13 for details.

Table 12 ADC Enable Control

HPFCUT	FS (KHZ)								
	SR=101/100			SR=011/010			SR=001/000		
	8	11.025	12	16	22.05	24	32	44.1	48
000	82	113	122	82	113	122	82	113	122
001	102	141	153	102	141	153	102	141	153
010	131	180	156	131	180	156	131	180	156
011	163	225	245	163	225	245	163	225	245
100	204	281	306	204	281	306	204	281	306
101	261	360	392	261	360	392	261	360	392
110	327	450	490	327	450	490	327	450	490
111	408	563	612	408	563	612	408	563	612

Table 13 High Pass Filter Cut-off Frequencies (HPFAPP=1)

Note that the High Pass filter values (when HPFAPP=1) work on the basis that the SR register bits are set correctly for the actual sample rate as shown in Table 13.

PROGRAMMABLE NOTCH FILTER

A programmable notch filter is provided. This filter has a variable centre frequency and bandwidth, programmable via two coefficients, a0 and a1. a0 and a1 are represented by the register bits NFA0[13:0] and NFA1[13:0]. Because these coefficient values require four register writes to setup there is an NFU (Notch Filter Update) flag which should be set only when all four registers are setup.

REGISTER ADDRESS	BIT	LABEL	DEFAULT	DESCRIPTION
R27 Notch Filter 1	6:0	NFA0[6:0]	0	Notch Filter a0 coefficient, bits [6:0]
	7	NFEN	0	Notch filter enable: 0=Disabled 1=Enabled
	8	NFU	0	Notch filter update. The notch filter values used internally only update when one of the NFU bits is set high.
R28 Notch Filter 2	6:0	NFA0[13:7]	0	Notch Filter a0 coefficient, bits [13:7]
	8	NFU	0	Notch filter update. The notch filter values used internally only update when one of the NFU bits is set high.
R29 Notch Filter 3	6:0	NFA1[6:0]	0	Notch Filter a1 coefficient, bits [6:0]
	8	NFU	0	Notch filter update. The notch filter values used internally only update when one of the NFU bits is set high.
R30 Notch Filter 4	0-6	NFA1[13:7]	0	Notch Filter a1 coefficient, bits [13:7]
	8	NFU	0	Notch filter update. The notch filter values used internally only update when one of the NFU bits is set high.

Table 14 Notch Filter Function

The coefficients are calculated as follows:

$$a_0 = \frac{1 - \tan(w_b / 2)}{1 + \tan(w_b / 2)}$$

$$a_1 = -(1 + a_0) \cos(w_0)$$

Where:

$$w_0 = 2\pi f_c / f_s$$

$$w_b = 2\pi f_b / f_s$$

f_c = centre frequency in Hz, f_b = -3dB bandwidth in Hz, f_s = sample frequency in Hz

The actual register values can be determined from the coefficients as follows:

$$\text{NFA0} = -a_0 \times 2^{13}$$

$$\text{NFA1} = -a_1 \times 2^{12}$$

DIGITAL ADC VOLUME CONTROL

The output of the ADCs can be digitally attenuated over a range from -127dB to 0dB in 0.5dB steps. The gain for a given eight-bit code X is given by:

$$0.5 \times (G-255) \text{ dB for } 1 \leq G \leq 255; \quad \text{MUTE for } G = 0$$

REGISTER ADDRESS	BIT	LABEL	DEFAULT	DESCRIPTION
R15 Left channel ADC Digital Volume	7:0	ADCVOLL [7:0]	11111111 (0dB)	Left ADC Digital Volume Control 0000 0000 = Digital Mute 0000 0001 = -127dB 0000 0010 = -126.5dB ... 0.5dB steps up to 1111 1111 = 0dB
	8	ADCVU	Not latched	ADC left and ADC right volume do not update until a 1 is written to ADCVU (in reg 16 or 17)
R16 Right channel ADC Digital Volume	7:0	ADCVOLR [7:0]	11111111 (0dB)	Right ADC Digital Volume Control 0000 0000 = Digital Mute 0000 0001 = -127dB 0000 0010 = -126.5dB ... 0.5dB steps up to 1111 1111 = 0dB
	8	ADCVU	Not latched	ADC left and ADC right volume do not update until a 1 is written to ADCVU (in reg 16 or 17)

Table 15 ADC Digital Volume Control

INPUT LIMITER / AUTOMATIC LEVEL CONTROL (ALC)

The WM8980 has an automatic PGA gain control circuit, which can function as an input peak limiter or as an automatic level control (ALC).

In input peak limiter mode (ALCMODE bit = 1), a digital peak detector detects when the input signal goes above a predefined level and will ramp the PGA gain down to prevent the signal becoming too large for the input range of the ADC. When the signal returns to a level below the threshold, the PGA gain is slowly returned to its starting level. The peak limiter cannot increase the PGA gain above its static level.

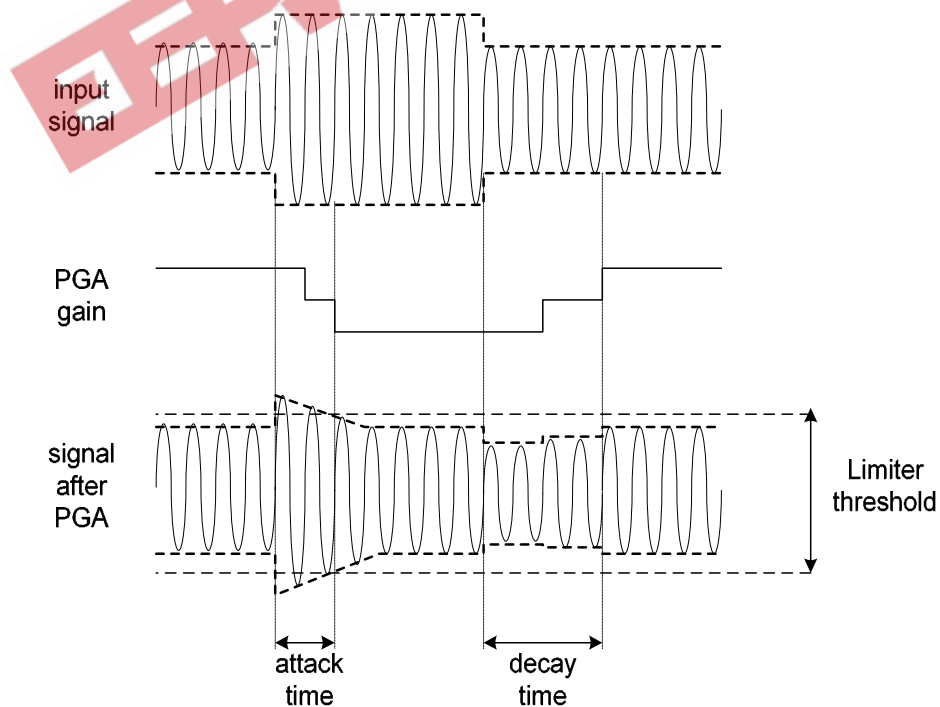

Figure 10 Input Peak Limiter Operation

In ALC mode (ALCMODE bit = 0) the circuit aims to keep a constant recording volume irrespective of the input signal level. This is achieved by continuously adjusting the PGA gain so that the signal level at the ADC input remains constant. A digital peak detector monitors the ADC output and changes the PGA gain if necessary.

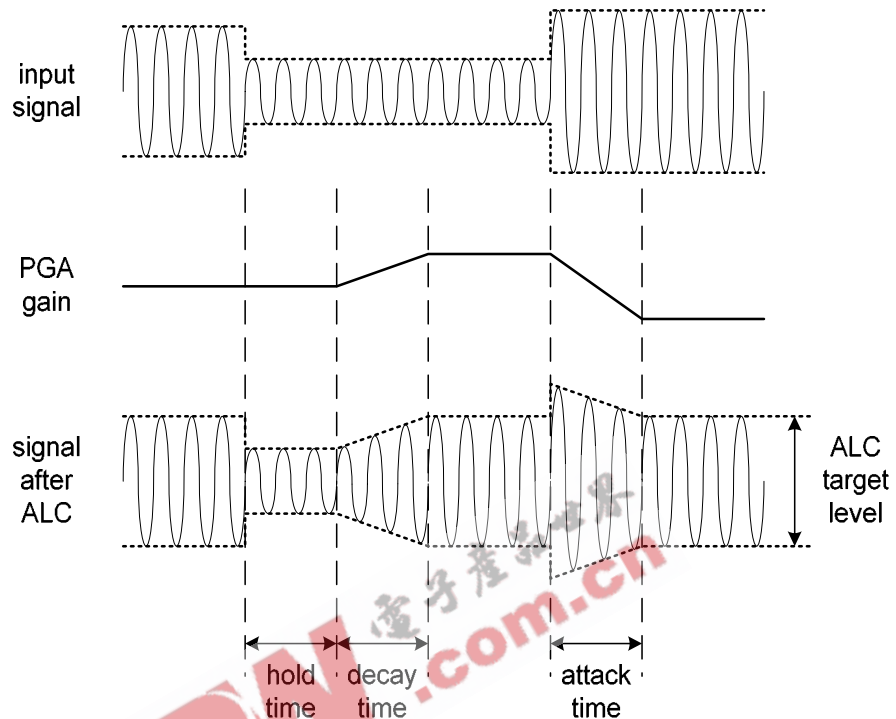

Figure 11 ALC Operation

The ALC/Limiter function is enabled by setting the register bit ALCSEL. When enabled, the recording volume can be programmed between -6dB and -28.5dB (relative to ADC full scale) using the ALCLVL register bits. An upper limit for the PGA gain can be imposed by setting the ALCMAX control bits and a lower limit for the PGA gain can be imposed by setting the ALCMIN control bits.

ALCHLD, ALCDCY and ALCATK control the hold, decay and attack times, respectively:

Hold time is the time delay between the peak level detected being below target and the PGA gain beginning to ramp up. It can be programmed in power-of-two (2^n) steps, e.g. 2.67ms, 5.33ms, 10.67ms etc. up to 43.7s. Alternatively, the hold time can also be set to zero. The hold time is not active in limiter mode (ALCMODE = 1). The hold time only applies to gain ramp-up, there is no delay before ramping the gain down when the signal level is above target.

Decay (Gain Ramp-Up) Time is the time that it takes for the PGA gain to ramp up and is given as a time per gain step, time per 6dB change and time to ramp up over 90% of it's range. The decay time can be programmed in power-of-two (2^n) steps, from 3.3ms/6dB, 6.6ms/6dB, 13.1ms/6dB, etc. to 3.36s/6dB.

Attack (Gain Ramp-Down) Time is the time that it takes for the PGA gain to ramp down and is given as a time per gain step, time per 6dB change and time to ramp down over 90% of it's range. The attack time can be programmed in power-of-two (2^n) steps, from 832us/6dB, 1.66ms/6dB, 3.328us/6dB, etc. to 852ms/6dB.

NB, In peak limiter mode the gain control circuit runs approximately 4x faster to allow reduction of fast peaks. Attack and Decay times for peak limiter mode are given below.

The hold, decay and attack times given in Table 16 are constant across sample rates so long as the SR bits are set correctly. E.g. when sampling at 48kHz the sample rates stated in Table 16 will only be correct if the SR bits are set to 000 (48kHz). If the actual sample rate was only 44.1kHz then the hold, decay and attack times would be scaled down by 44.1/48.

REGISTER ADDRESS	BIT	LABEL	DEFAULT	DESCRIPTION
R32 ALC Control 1	8:7	ALCSEL	00	ALC function select 00=ALC disabled 01=Right channel ALC enabled 10=Left channel ALC enabled 11=Both channels ALC enabled
	5:3	ALCMAXGAIN [2:0]	111 (+35.25dB)	Set Maximum Gain of PGA 111=+35.25dB 110=+29.25dB 101=+23.25dB 100=+17.25dB 011=+11.25dB 010=+5.25dB 001=-0.75dB 000=-6.75dB
	2:0	ALCMINGAIN [2:0]	000 (-12dB)	Set minimum gain of PGA 000=-12dB 001=-6dB 010=0dB 011=+6dB 100=+12dB 101=+18dB 110=+24dB 111=+30dB
R33 ALC Control 2	7:4	ALCHLD [3:0]	0000 (0ms)	ALC hold time before gain is increased. 0000 = 0ms 0001 = 2.67ms 0010 = 5.33ms ... (time doubles with every step) 1111 = 43.691s
	3:0	ALCLVL [3:0]	1011 (-12dB)	ALC target – sets signal level at ADC input 0000 = -28.5dB FS 0001 = -27.0dB FS ... (1.5dB steps) 1110 = -7.5dB FS 1111 = -6dB FS
	8	ALCZC	0 (zero cross off)	ALC uses zero cross detection circuit.

R34 ALC Control 3	8	ALCMODE	0	Determines the ALC mode of operation: 0=ALC mode 1=Limiter mode			
	7:4	ALCDCY [3:0]	0011 (13ms/6dB)	Decay (gain ramp-up) time (ALCMODE ==0)			
					Per step	Per 6dB	90% of range
				0000	410us	3.3ms	24ms
				0001	820us	6.6ms	48ms
				0010	1.64ms	13.1ms	192ms
				... (time doubles with every step)			
				1010 or higher	420ms	3.36s	24.576s
				0011 (2.9ms/6dB)	Decay (gain ramp-up) time (ALCMODE ==1)		
		Per step	Per 6dB		90% of range		
0000	90.8us	726.4us	5.26ms				
0001	181.6us	1.453ms	10.53ms				
0010	363.2us	2.905ms	21.06ms				
... (time doubles with every step)							
1010	93ms	744ms	5.39s				
3:0	ALCATK [3:0]	0010 (832us/6dB)	ALC attack (gain ramp-down) time (ALCMODE == 0)				
				Per step	Per 6dB	90% of range	
			0000	104us	832us	6ms	
			0001	208us	1.664ms	12ms	
			0010	416us	3.328ms	24.1ms	
			... (time doubles with every step)				
			1010 or higher	106ms	852ms	6.18s	
			0010 (182us/6dB)	ALC attack (gain ramp-down) time (ALCMODE == 1)			
				Per step	Per 6dB	90% of range	
		0000		22.7us	182.4us	1.31ms	
0001	45.4us	363.2us		2.62ms			
0010	90.8us	726.4us	5.26ms				
... (time doubles with every step)							
1010	23.2ms	186ms	1.348s				

Table 16 ALC Control Registers

ALC CLIP PROTECTION

To prevent clipping when a large signal occurs just after a period of quiet, the ALC circuit includes a clip protection function. If the ADC input signal exceeds 87.5% of full scale (-1.16dB), the PGA gain is ramped down at the maximum attack rate (as when ALCATK = 0000), until the signal level falls below 87.5% of full scale. This function is automatically enabled whenever the ALC is enabled.

Note:

If ATK = 0000, then the clip protection circuit makes no difference to the operation of the ALC. It is designed to prevent clipping when long attack times are used.

NOISE GATE

When the signal is very quiet and consists mainly of noise, the ALC function may cause “noise pumping”, i.e. loud hissing noise during silence periods. The WM8980 has a noise gate function that prevents noise pumping by comparing the signal level at the input pins against a noise gate threshold, NGTH. The noise gate cuts in when:

$$\text{Signal level at ADC [dB]} < \text{NGTH [dB]} + \text{PGA gain [dB]} + \text{Mic Boost gain [dB]}$$

This is equivalent to:

$$\text{Signal level at input pin [dB]} < \text{NGTH [dB]}$$

The PGA gain is then held constant (preventing it from ramping up as it normally would when the signal is quiet).

The table below summarises the noise gate control register. The NGTH control bits set the noise gate threshold with respect to the ADC full-scale range. The threshold is adjusted in 6dB steps. Levels at the extremes of the range may cause inappropriate operation, so care should be taken with set-up of the function. Note that the noise gate only works in conjunction with the ALC function.

REGISTER ADDRESS	BIT	LABEL	DEFAULT	DESCRIPTION
R35 ALC Noise Gate Control	2:0	NGTH	000	Noise gate threshold: 000=-39dB 001=-45dB 010=-51db ... (6dB steps) 111=-81dB
	3	NGATEN	0	Noise gate function enable 1 = enable 0 = disable

Table 17 ALC Noise Gate Control

OUTPUT SIGNAL PATH

The WM8980 output signal paths consist of digital application filters, up-sampling filters, stereo Hi-Fi DACs, analogue mixers, speaker, stereo headphone and stereo line/mono/midrail output drivers. The digital filters and DAC are enabled by register bits DACENL And DACENR. The mixers and output drivers can be separately enabled by individual control bits (see Analogue Outputs). Thus it is possible to utilise the analogue mixing and amplification provided by the WM8980, irrespective of whether the DACs are running or not.

The WM8980 DACs receive digital input data on the DACDAT pin. The digital filter block processes the data to provide the following functions:

- § Digital volume control
- § Graphic equaliser
- § A digital peak limiter.
- § Sigma-Delta Modulation

High performance sigma-delta audio DAC converts the digital data into an analogue signal.

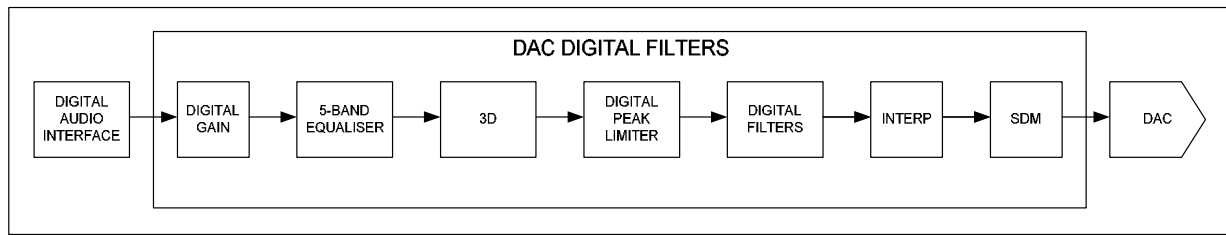

Figure 12 DAC Digital Filter Path

The analogue outputs from the DACs can then be mixed with the aux analogue inputs and the ADC analogue inputs. The mix is fed to the output drivers for headphone (LOUT1/ROUT1), speaker (LOUT2/ROUT2) or line (OUT3/OUT4). OUT3 and OUT4 have additional mixers which allow them to output different signals to the headphone and speaker outputs.

DIGITAL PLAYBACK (DAC) PATH

Digital data is passed to the WM8980 via the flexible audio interface and is then passed through a variety of advanced digital filters as shown in Figure 12 to the hi-fi DACs. The DACs are enabled by the DACENL/R register bits.

REGISTER ADDRESS	BIT	LABEL	DEFAULT	DESCRIPTION
R3 Power Management 3	0	DACENL	0	Left channel DAC enable 0 = DAC disabled 1 = DAC enabled
	1	DACENR	0	Right channel DAC enable 0 = DAC disabled 1 = DAC enabled

Table 18 DAC Enable Control

The WM8980 also has a Soft Mute function, which gradually attenuates the volume of the digital signal to zero. When removed, the gain will ramp back up to the digital gain setting.

REGISTER ADDRESS	BIT	LABEL	DEFAULT	DESCRIPTION
R10 DAC Control	0	DACPOLL	0	Left DAC output polarity: 0 = non-inverted 1 = inverted (180 degrees phase shift)
	1	DACPOLR	0	Right DAC output polarity: 0 = non-inverted 1 = inverted (180 degrees phase shift)
	2	AMUTE	0	Automute enable 0 = Amute disabled 1 = Amute enabled
	3	DACOSR	0	DAC oversampling rate: 0=64x (lowest power) 1=128x (best performance)
	6	SOFTMUTE	0	Softmute enable: 0=Disabled 1=Enabled

Table 19 DAC Control Register

The digital audio data is converted to oversampled bit streams in the on-chip, true 24-bit digital interpolation filters. The bitstream data enters the multi-bit, sigma-delta DACs, which convert it to a high quality analogue audio signal. The multi-bit DAC architecture reduces high frequency noise and sensitivity to clock jitter. It also uses a Dynamic Element Matching technique for high linearity and low distortion.

The DAC output defaults to non-inverted. Setting DACPOLL will invert the DAC output phase on the left channel and DACPOLR inverts the phase on the right channel.

AUTOMUTE

The DAC has an automute function which applies an analogue mute when 1024 consecutive zeros are detected. The mute is released as soon as a non-zero sample is detected. Automute can be disabled using the AMUTE control bit.

DIGITAL HI-FI DAC VOLUME (GAIN) CONTROL

The signal volume from each Hi-Fi DAC can be controlled digitally. The gain and attenuation range is -127dB to 0dB in 0.5dB steps. The level of attenuation for an eight-bit code X is given by:

$$0.5 \times (X-255) \text{ dB for } 1 \leq X \leq 255; \quad \text{MUTE for } X = 0$$

REGISTER ADDRESS	BIT	LABEL	DEFAULT	DESCRIPTION
R11 Left DAC Digital Volume	7:0	DACVOLL [7:0]	11111111 (0dB)	Left DAC Digital Volume Control 0000 0000 = Digital Mute 0000 0001 = -127dB 0000 0010 = -126.5dB ... 0.5dB steps up to 1111 1111 = 0dB
	8	DACVU	Not latched	DAC left and DAC right volume do not update until a 1 is written to DACVU (in reg 11 or 12)
R12 Right DAC Digital Volume	7:0	DACVOLR [7:0]	11111111 (0dB)	Right DAC Digital Volume Control 0000 0000 = Digital Mute 0000 0001 = -127dB 0000 0010 = -126.5dB ... 0.5dB steps up to 1111 1111 = 0dB
	8	DACVU	Not latched	DAC left and DAC right volume do not update until a 1 is written to DACVU (in reg 11 or 12)

Table 20 DAC Digital Volume Control

Note: An additional gain of up to $+12\text{dB}$ can be added using the gain block embedded in the digital peak limiter circuit (see DAC OUTPUT LIMITER section).

DAC 5-BAND EQUALISER

A 5-band graphic equaliser function which can be used to change the output frequency levels to suit the environment. This can be applied to the ADC or DAC path and is described in the 5-BAND EQUALISER section for further details on this feature.

DAC 3-D ENHANCEMENT

The WM8980 has an advanced digital 3-D enhancement feature which can be used to vary the perceived stereo separation of the left and right channels. Like the 5-band equaliser this feature can be applied to either the record path or the playback path but not both simultaneously. See the 3-D STEREO ENHANCEMENT section for further details on this feature.

DAC DIGITAL OUTPUT LIMITER

The WM8980 has a digital output limiter function. The operation of this is shown in Figure 13. In this diagram the upper graph shows the envelope of the input/output signals and the lower graph shows the gain characteristic.

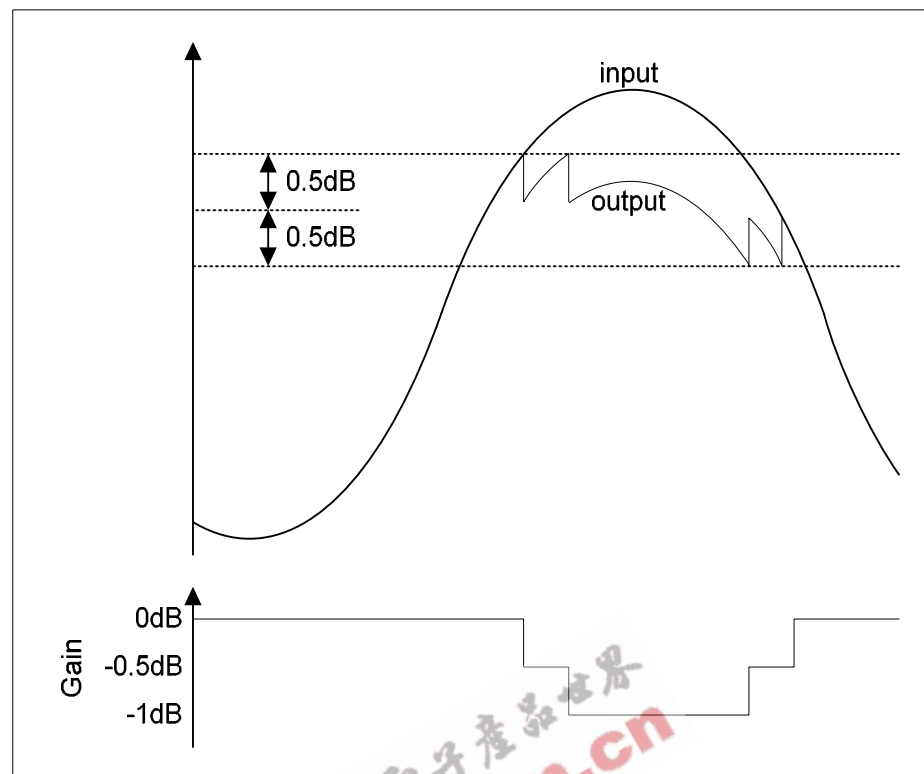

Figure 13 DAC Digital Limiter Operation

The limiter has a programmable upper threshold which is close to 0dB. Referring to Figure 13, in normal operation (LIMBOOST=000 => limit only) signals below this threshold are unaffected by the limiter. Signals above the upper threshold are attenuated at a specific attack rate (set by the LIMATK register bits) until the signal falls below the threshold. The limiter also has a lower threshold 1dB below the upper threshold. When the signal falls below the lower threshold the signal is amplified at a specific decay rate (controlled by LIMDCY register bits) until a gain of 0dB is reached. Both threshold levels are controlled by the LIMLVL register bits. The upper threshold is 0.5dB above the value programmed by LIMLVL and the lower threshold is 0.5dB below the LIMLVL value.

VOLUME BOOST

The limiter has programmable upper gain which boosts signals below the threshold to compress the dynamic range of the signal and increase its perceived loudness. This operates as an ALC function with limited boost capability. The volume boost is from 0dB to +12dB in 1dB steps, controlled by the LIMBOOST register bits.

The output limiter volume boost can also be used as a stand alone digital gain boost when the limiter is disabled.

REGISTER ADDRESS	BIT	LABEL	DEFAULT	DESCRIPTION
R24 DAC digital limiter control 1	3:0	LIMATK	0010	Limiter Attack time (per 6dB gain change) for 44.1kHz sampling. Note that these will scale with sample rate. 0000=94us 0001=188s 0010=375us 0011=750us 0100=1.5ms 0101=3ms 0110=6ms 0111=12ms 1000=24ms 1001=48ms 1010=96ms 1011 to 1111=192ms
	7:0	LIMDCY	0011	Limiter Decay time (per 6dB gain change) for 44.1kHz sampling. Note that these will scale with sample rate: 0000=750us 0001=1.5ms 0010=3ms 0011=6ms 0100=12ms 0101=24ms 0110=48ms 0111=96ms 1000=192ms 1001=384ms 1010=768ms 1011 to 1111=1.536s
	8	LIMEN	0	Enable the DAC digital limiter: 0=disabled 1=enabled
R25 DAC digital limiter control 2	3:0	LIMBOOST	0000	Limiter volume boost (can be used as a stand alone volume boost when LIMEN=0): 0000=0dB 0001=+1dB 0010=+2dB ... (1dB steps) 1011=+11dB 1100=+12dB 1101 to 1111=reserved
	6:4	LIMLVL	000	Programmable signal threshold level (determines level at which the limiter starts to operate) 000=-1dB 001=-2dB 010=-3dB 011=-4dB 100=-5dB 101 to 111=-6dB

Table 21 DAC Digital Limiter Control

5-BAND GRAPHIC EQUALISER

A 5-band graphic EQ is provided, which can be applied to the ADC or DAC path, together with 3D enhancement, under control of the EQ3DMODE register bit.

REGISTER ADDRESS	BIT	LABEL	DEFAULT	DESCRIPTION
R18 EQ Control 1	8	EQ3DMODE	1	0 = Equaliser and 3D Enhancement applied to ADC path 1 = Equaliser and 3D Enhancement applied to DAC path

Table 22 EQ and 3D Enhancement DAC or ADC Path Select

The equaliser consists of low and high frequency shelving filters (Band 1 and 5) and three peak filters for the centre bands. Each has adjustable cut-off or centre frequency, and selectable boost (+/- 12dB in 1dB steps). The peak filters have selectable bandwidth.

REGISTER ADDRESS	BIT	LABEL	DEFAULT	DESCRIPTION
R18 EQ Band 1 Control	4:0	EQ1G	01100 (0dB)	Band 1 Gain Control. See Table 28 for details.
	6:5	EQ1C	01	Band 1 Cut-off Frequency: 00=80Hz 01=105Hz 10=135Hz 11=175Hz

Table 23 EQ Band 1 Control

REGISTER ADDRESS	BIT	LABEL	DEFAULT	DESCRIPTION
R19 EQ Band 2 Control	4:0	EQ2G	01100 (0dB)	Band 2 Gain Control. See Table 28 for details.
	6:5	EQ2C	01	Band 2 Centre Frequency: 00=230Hz 01=300Hz 10=385Hz 11=500Hz
	8	EQ2BW	0	Band 2 Bandwidth Control 0=narrow bandwidth 1=wide bandwidth

Table 24 EQ Band 2 Control

REGISTER ADDRESS	BIT	LABEL	DEFAULT	DESCRIPTION
R20 EQ Band 3 Control	4:0	EQ3G	01100 (0dB)	Band 3 Gain Control. See Table 28 for details.
	6:5	EQ3C	01	Band 3 Centre Frequency: 00=650Hz 01=850Hz 10=1.1kHz 11=1.4kHz
	8	EQ3BW	0	Band 3 Bandwidth Control 0=narrow bandwidth 1=wide bandwidth

Table 25 EQ Band 3 Control

REGISTER ADDRESS	BIT	LABEL	DEFAULT	DESCRIPTION
R21 EQ Band 4 Control	4:0	EQ4G	01100 (0dB)	Band 4 Gain Control. See Table 28 for details
	6:5	EQ4C	01	Band 4 Centre Frequency: 00=1.8kHz 01=2.4kHz 10=3.2kHz 11=4.1kHz
	8	EQ4BW	0	Band 4 Bandwidth Control 0=narrow bandwidth 1=wide bandwidth

Table 26 EQ Band 4 Control

REGISTER ADDRESS	BIT	LABEL	DEFAULT	DESCRIPTION
R22 EQ Band 5 Gain Control	4:0	EQ5G	01100 (0dB)	Band 5 Gain Control. See Table 28 for details.
	6:5	EQ5C	01	Band 5 Cut-off Frequency: 00=5.3kHz 01=6.9kHz 10=9kHz 11=11.7kHz

Table 27 EQ Band 5 Control

GAIN REGISTER	GAIN
00000	+12dB
00001	+11dB
00010	+10dB
.... (1dB steps)	
01100	0dB
01101	-1dB
11000 to 11111	-12dB

Table 28 Gain Register Table

3D STEREO ENHANCEMENT

The WM8980 has a digital 3D enhancement option to artificially increase the separation between the left and right channels. Selection of 3D for record or playback is controlled by register bit EQ3DMODE. Switching this bit from record to playback or from playback to record may only be done when ADC and DAC are disabled. The WM8980 control interface will only allow EQ3DMODE to be changed when ADC and DAC are disabled (ie ADCENL = 0, ADCENR = 0, DACENL = 0 and DACENR = 0).

The DEPTH3D setting controls the degree of stereo expansion.

When 3D enhancement is used, it may be necessary to attenuate the signal by 6dB to avoid limiting.

REGISTER ADDRESS	BIT	LABEL	DEFAULT	DESCRIPTION
R41 (29h) 3D	3:0	DEPTH3D[3:0]	0000	Stereo depth 0000: 0% (minimum 3D effect) 0001: 6.67% 1110: 93.3% 1111: 100% (maximum 3D effect)

Table 29 3D Stereo Enhancement Function

ANALOGUE OUTPUTS

The WM8980 has three sets of stereo analogue outputs. These are:

- LOUT1 and ROUT1 which are normally used to drive a headphone load.
- LOUT2 and ROUT2 – normally used to drive an 8Ω BTL speaker.
- OUT3 and OUT4 – can be configured as a stereo line out (OUT3 is left output and OUT4 is right output). OUT4 can also be used to provide a mono mix of left and right channels.

LOUT2, ROUT2, OUT3 and OUT4 are supplied from SPKVDD and are capable of driving up to 1.5Vrms signals as shown in Figure 14. LOUT1 and ROUT1 are supplied from AVDD and can only drive out a 1V rms signal (AVDD/3.3).

LOUT1, ROUT1, LOUT2 and ROUT2 have individual analogue volume PGAs with -57dB to +6dB ranges.

There are four output mixers in the output signal path, the left and right channel mixers which control the signals to speaker, headphone (and optionally the line outputs) and also dedicated OUT3 and OUT4 mixers.

LEFT AND RIGHT OUTPUT CHANNEL MIXERS

The left and right output channel mixers are shown in Figure 14. These mixers allow the AUX inputs, the ADC bypass and the DAC left and right channels to be combined as desired. This allows a mono mix of the DAC channels to be done as well as mixing in external line-in from the AUX or speech from the input bypass path.

The AUX and bypass inputs have individual volume control from -15dB to +6dB and the DAC volume can be adjusted in the digital domain if required. The output of these mixers goes to both the headphone (LOUT1 and ROUT1) and speaker (LOUT2 and ROUT2) and can optionally go to the OUT3 and OUT4 mixers.

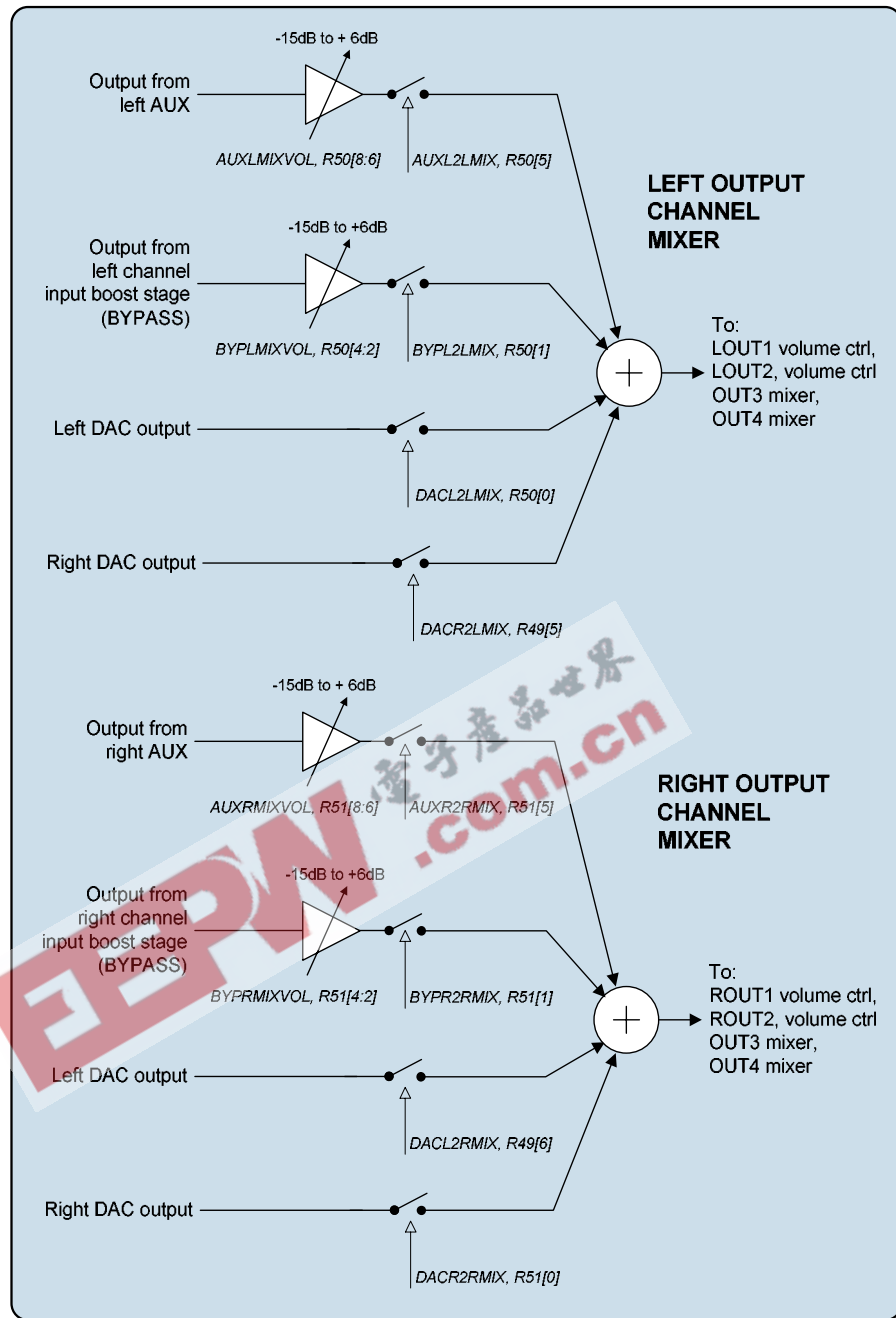

Figure 14 Left/Right Output Channel Mixers

REGISTER ADDRESS	BIT	LABEL	DEFAULT	DESCRIPTION
R49 Output mixer control	5	DACR2LMIX	0	Right DAC output to left output mixer 0 = not selected 1 = selected
	6	DACL2RMIX	0	Left DAC output to right output mixer 0 = not selected 1 = selected
R50 Left channel output mixer control	0	DACL2LMIX	1	Left DAC output to left output mixer 0 = not selected 1 = selected
	1	BYPL2LMIX	0	Left bypass path (from the left channel input boost output) to left output mixer 0 = not selected 1 = selected
	4:2	BYPLMIXVOL	000	Left bypass volume control to output channel mixer: 000 = -15dB 001 = -12dB ... 101 = 0dB 110 = +3dB 111 = +6dB
	5	AUXL2LMIX	0	Left Auxilliary input to left channel output mixer: 0 = not selected 1 = selected
	8:6	AUXLMIXVOL	000	Aux left channel input to left mixer volume control: 000 = -15dB 001 = -12dB ... 101 = 0dB 110 = +3dB 111 = +6dB

R51 Right channel output mixer control	0	DACR2RMIX	1	Right DAC output to right output mixer 0 = not selected 1 = selected
	1	BYPR2RMIX	0	Right bypass path (from the right channel input boost output) to right output mixer 0 = not selected 1 = selected
	4:2	BYPRMIXVOL	000	Right bypass volume control to output channel mixer: 000 = -15dB 001 = -12dB ... 101 = 0dB 110 = +3dB 111 = +6dB
	5	AUXR2RMIX	0	Right Auxiliary input to right channel output mixer: 0 = not selected 1 = selected
	8:6	AUXRMIXVOL	000	Aux right channel input to right mixer volume control: 000 = -15dB 001 = -12dB ... 101 = 0dB 110 = +3dB 111 = +6dB
R3 Power management	2	LMIXEN	0	Left output channel mixer enable: 0 = disabled 1 = enabled
	3	RMIXEN	0	Right output channel mixer enable: 0 = disabled 1 = enabled

Table 30 Left and Right Output Mixer Control

HEADPHONE OUTPUTS (LOUT1 AND ROUT1)

The headphone outputs, LOUT1 and ROUT1 can drive a 16Ω or 32Ω headphone load, either through DC blocking capacitors, or DC coupled without any capacitor. Each headphone output has an analogue volume control PGA with a gain range of -57dB to +6dB as shown in Figure 17.

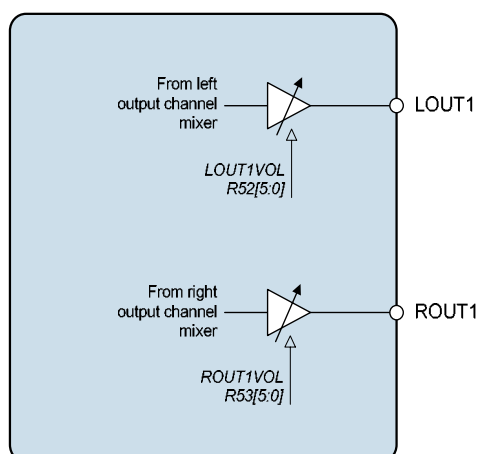
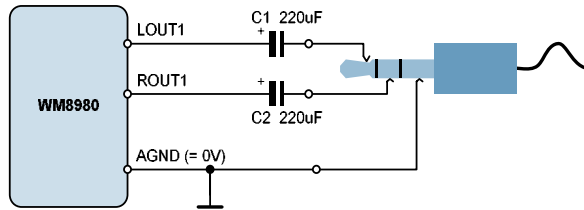
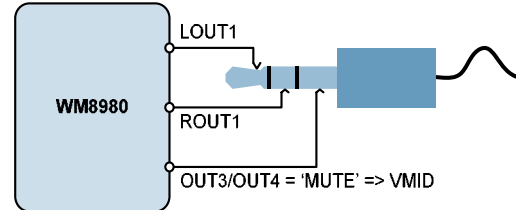

Figure 15 Headphone Outputs LOUT1 and ROUT1

REGISTER ADDRESS	BIT	LABEL	DEFAULT	DESCRIPTION
R52 LOUT1 Volume control	7	LOUT1ZC	0	Headphone volume zero cross enable: 1 = Change gain on zero cross only 0 = Change gain immediately
	6	LOUT1MUTE	0	Left headphone output mute: 0 = Normal operation 1 = Mute
	5:0	LOUT1VOL	111001	Left headphone output volume: 000000 = -57dB ... 111001 = 0dB ... 111111 = +6dB
	8	HPVU	Not latched	LOUT1 and ROUT1 volumes do not update until a 1 is written to HPVU (in reg 52 or 53)
R53 ROUT1 Volume control	7	ROUT1ZC	0	Headphone volume zero cross enable: 1 = Change gain on zero cross only 0 = Change gain immediately
	6	ROUT1MUTE	0	Right headphone output mute: 0 = Normal operation 1 = Mute
	5:0	ROUT1VOL	111001	Right headphone output volume: 000000 = -57dB ... 111001 = 0dB ... 111111 = +6dB
	8	HPVU	Not latched	LOUT1 and ROUT1 volumes do not update until a 1 is written to HPVU (in reg 52 or 53)

Table 31 OUT1 Volume Control

Headphone Output using DC Blocking Capacitors:**DC Coupled Headphone Output:****Figure 16 Recommended Headphone Output Configurations**

When DC blocking capacitors are used, then their capacitance and the load resistance together determine the lower cut-off frequency, f_c . Increasing the capacitance lowers f_c , improving the bass response. Smaller capacitance values will diminish the bass response. Assuming a 16Ω load and $C_1, C_2 = 220\mu\text{F}$:

$$f_c = 1 / 2\pi R_L C_1 = 1 / (2\pi \times 16\Omega \times 220\mu\text{F}) = 45 \text{ Hz}$$

In the DC coupled configuration, the headphone “ground” is connected to the VMID pin. The OUT3/4 pins can be configured as a DC output driver by setting the OUT3MUTE and OUT4MUTE register bit. The DC voltage on VMID in this configuration is equal to the DC offset on the LOUT1 and ROUT1 pins therefore no DC blocking capacitors are required. This saves space and material cost in portable applications.

Note that OUT3 and OUT4 have an optional output boost of 1.5x. When these are configured in this output boost mode (OUT3BOOST/OUT4BOOST=1) then the VMID value of these outputs will be equal to $1.5 \times \text{AVDD}/2$ and will not match the VMID of the headphone drivers. Do not use the DC coupled output mode in this configuration.

It is recommended to connect the DC coupled outputs only to headphones, and not to the line input of another device. Although the built-in short circuit protection will prevent any damage to the headphone outputs, such a connection may be noisy, and may not function properly if the other device is grounded.

SPEAKER OUTPUTS (LOUT2 AND ROUT2)

The outputs LOUT2 and ROUT2 are designed to drive an 8Ω BTL speaker but can optionally drive two headphone loads of $16\Omega/32\Omega$ or a line output (see Headphone Output and Line Output sections, respectively). Each output has an individual volume control PGA, an output boost/level shift bit, a mute and an enable as shown in Figure 17. LOUT2 and ROUT2 output the left and right channel mixer outputs respectively.

The ROUT2 signal path also has an optional invert. The amplifier used for this invert can be used to mix in the AUXR signal with an adjustable gain range of $-15\text{dB} \rightarrow +6\text{dB}$. This allows a ‘beep’ signal to be applied only to the speaker output without affecting the HP or line outputs.

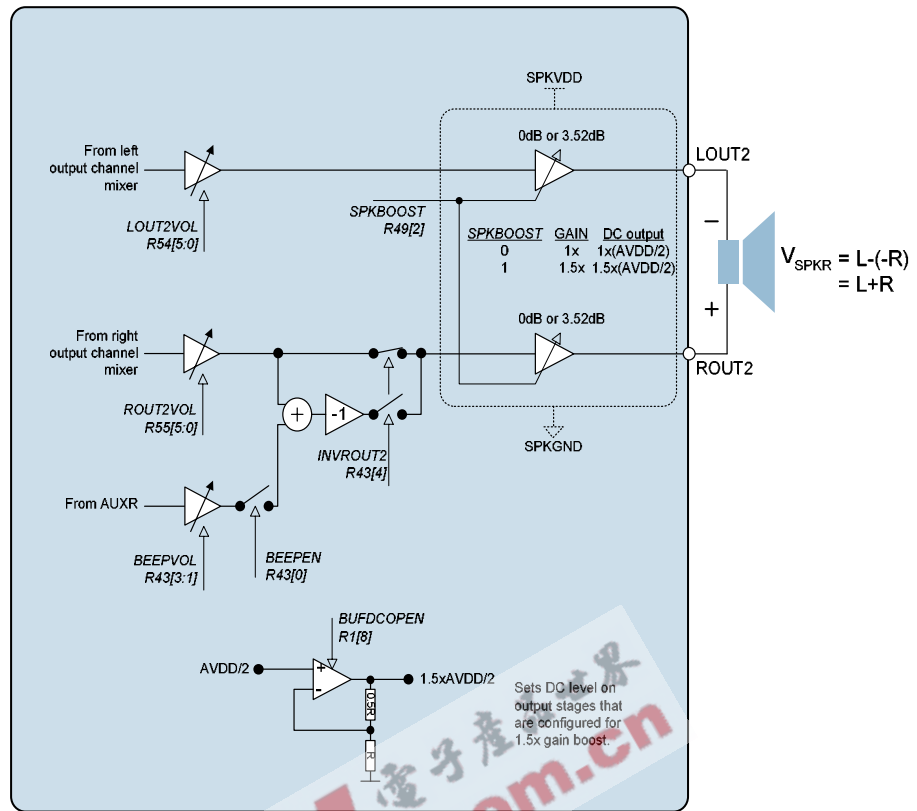

Figure 17 Speaker Outputs LOUT2 and ROUT2

REGISTER ADDRESS	BIT	LABEL	DEFAULT	DESCRIPTION
R54 LOUT2 (SPK) Volume control	7	LOUT2ZC	0	Speaker volume zero cross enable: 1 = Change gain on zero cross only 0 = Change gain immediately
	6	LOUT2MUTE	0	Left speaker output mute: 0 = Normal operation 1 = Mute
	5:0	LOUT2VOL	111001	Left speaker output volume: 000000 = -57dB ... 111001 = 0dB ... 111111 = +6dB
	8	SPKVU	Not latched	LOUT2 and ROUT2 volumes do not update until a 1 is written to SPKVU (in reg 54 or 55)
R55 ROUT2 (SPK) Volume control	7	ROUT2ZC	0	Speaker volume zero cross enable: 1 = Change gain on zero cross only 0 = Change gain immediately
	6	ROUT2MUTE	0	Right speaker output mute: 0 = Normal operation 1 = Mute
	5:0	ROUT2VOL	111001	Right speaker output volume: 000000 = -57dB ... 111001 = 0dB ... 111111 = +6dB
	8	SPKVU	Not latched	LOUT2 and ROUT2 volumes do not update until a 1 is written to SPKVU (in reg 54 or 55)

Table 32 Speaker Volume Control

The signal to be output on LOUT2/ROUT2 comes from the Left/Right Mixer circuits and can be any combination of the DAC output, the Bypass path (output of the input boost stage) and the AUX input. The LOUT2/ROUT2 volume is controlled by the LOUT2VOL/ ROUT2VOL register bits. Note that gains over 0dB may cause clipping if the signal is large. The LOUT2MUTE/ ROUT2MUTE register bits cause the speaker outputs to be muted (the output DC level is driven out). The output pins remain at the same DC level (DCOP), so that no click noise is produced when muting or un-muting.

The speaker output stages also have a selectable gain boost of 1.5x (3.52dB). When this boost is enabled the output DC level is also level shifted (from AVDD/2 to 1.5xAVDD/2) to prevent the signal from clipping. A dedicated amplifier BUFDCOP, as shown in Figure 18, is used to perform the DC level shift operation. This buffer must be enabled using the BUFDCOPEN register bit for this operating mode. It should also be noted that if SPKVDD is not equal to or greater than 1.5xAVDD this boost mode may result in signals clipping. Table 34 summarises the effect of the SPKBOOST control bits.

REGISTER ADDRESS	BIT	LABEL	DEFAULT	DESCRIPTION
R49 Output control	2	SPKBOOST	0	0 = speaker gain = -1; DC = AVDD / 2 1 = speaker gain = +1.5; DC = 1.5 x AVDD / 2
R1 Power management 1	8	BUFDOPEN	0	Dedicated buffer for DC level shifting output stages when in 1.5x gain boost configuration. 0=Buffer disabled 1=Buffer enabled (required for 1.5x gain boost)

Table 33 Speaker Boost Stage Control

SPKBOOST	OUTPUT STAGE GAIN	OUTPUT DC LEVEL	OUTPUT STAGE CONFIGURATION
0	1x (0dB)	AVDD/2	Inverting
1	1.5x (3.52dB)	1.5xAVDD/2	Non-inverting

Table 34 Output Boost Stage Details

REGISTER ADDRESS	BIT	LABEL	DEFAULT	DESCRIPTION
R43 Beep control	5	MUTERPGA2INV	0	Mute input to INVROUT2 mixer
	4	INVROUT2	0	Invert ROUT2 output
	3:1	BEEPVOL	000	AUXR input to ROUT2 inverter gain 000 = -15dB ... 111 = +6dB
	0	BEEPEN	0	0 = mute AUXR beep input 1 = enable AUXR beep input

Table 35 AUXR – ROUT2 BEEP Mixer Function

ZERO CROSS TIMEOUT

A zero-cross timeout function is also provided so that if zero cross is enabled on the input or output PGAs the gain will automatically update after a timeout period if a zero cross has not occurred. This is enabled by setting SLOWCLKEN. The timeout period is dependent on the clock input to the digital and is equal to 2^{21} * input clock period.

REGISTER ADDRESS	BIT	LABEL	DEFAULT	DESCRIPTION
R7 Additional Control	0	SLOWCLKEN	0	Slow clock enable. Used for both the jack insert detect debounce circuit and the zero cross timeout. 0 = slow clock disabled 1 = slow clock enabled

Table 36 Timeout Clock Enable Control

EEPW.com.cn 电子产品世界

OUT3/OUT4 MIXERS AND OUTPUT STAGES

The OUT3/OUT4 pins can provide an additional stereo line output, a mono output, or a pseudo ground connection for headphones. There is a dedicated analogue mixer for OUT3 and one for OUT4 as shown in Figure 19.

The OUT3 and OUT4 output stages are powered from SPKVDD and SPKGND. The individually controllable outputs also incorporate an optional 1.5x boost and level shifting stage.

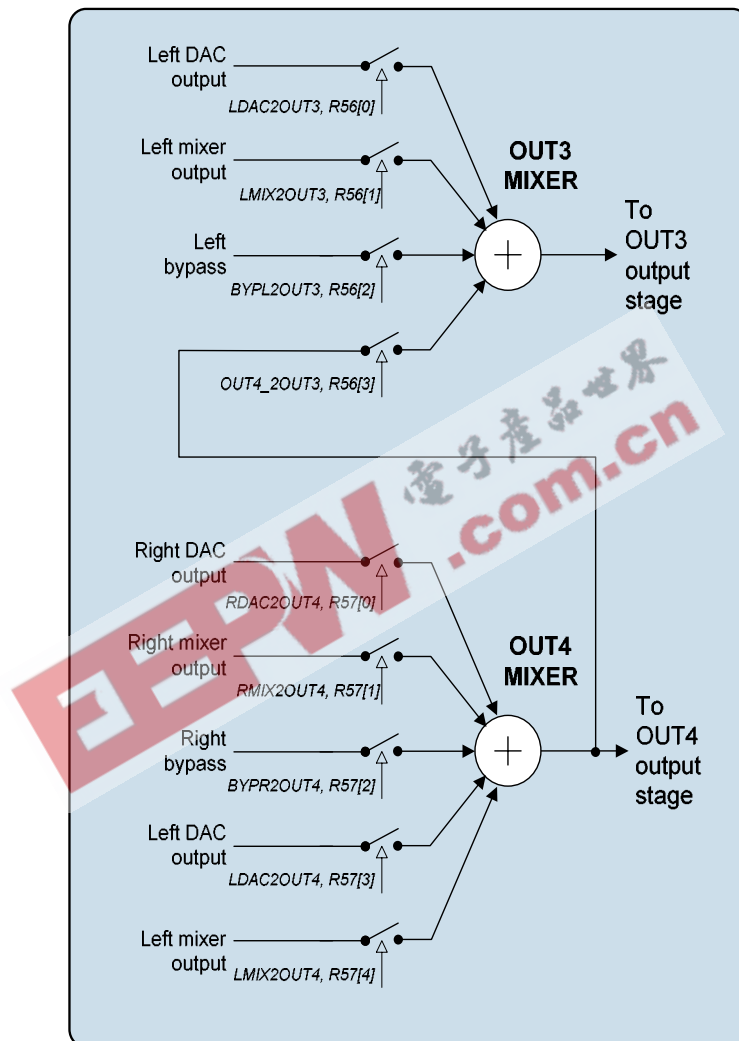

Figure 19 OUT3 and OUT4 Mixers

OUT3 can provide a buffered midrail headphone pseudo-ground, or a left line output.

OUT4 can provide a buffered midrail headphone pseudo-ground, a right line output, or a mono mix output.

REGISTER ADDRESS	BIT	LABEL	DEFAULT	DESCRIPTION
R56 OUT3 mixer control	6	OUT3MUTE	0	0 = Output stage outputs OUT3 mixer 1 = Output stage muted – drives out VMID. Can be used as VMID buffer in this mode.
	3	OUT4_2OUT3	0	OUT4 mixer output to OUT3 0 = disabled 1= enabled
	2	BYPL2OUT3	0	Left ADC input to OUT3 0 = disabled 1= enabled
	1	LMIX2OUT3	0	Left DAC mixer to OUT3 0 = disabled 1= enabled
	0	LDAC2OUT3	1	Left DAC output to OUT3 0 = disabled 1= enabled
R57 OUT4 mixer control	6	OUT4MUTE	0	0 = Output stage outputs OUT4 mixer 1 = Output stage muted – drives out VMID. Can be used as VMID buffer in this mode.
	5	HALFSIG	0	0=OUT4 normal output 1=OUT4 attenuated by 6dB
	4	LMIX2OUT4	0	Left DAC mixer to OUT4 0 = disabled 1= enabled
	3	LDAC2OUT4	0	Left DAC to OUT4 0 = disabled 1= enabled
	2	BYPR2OUT4	0	Right ADC input to OUT4 0 = disabled 1= enabled
	1	RMIX2OUT4	0	Right DAC mixer to OUT4 0 = disabled 1= enabled
	0	RDAC2OUT4	1	Right DAC output to OUT4 0 = disabled 1= enabled

Table 37 OUT3/OUT4 Mixer Registers

The OUT3 and OUT4 output stages each have a selectable gain boost of 1.5x (3.52dB). When this boost is enabled the output DC level is also level shifted (from AVDD/2 to 1.5xAVDD/2) to prevent the signal from clipping. A dedicated amplifier BUFDCOP, as shown in Figure 20, is used to perform the DC level shift operation. This buffer must be enabled using the BUFDCOPEN register bit for this operating mode. It should also be noted that if SPKVDD is not equal to or greater than 1.5xAVDD this boost mode may result in signals clipping. Table 34 summarises the effect of the OUT3BOOST and OUT4BOOST control bits.

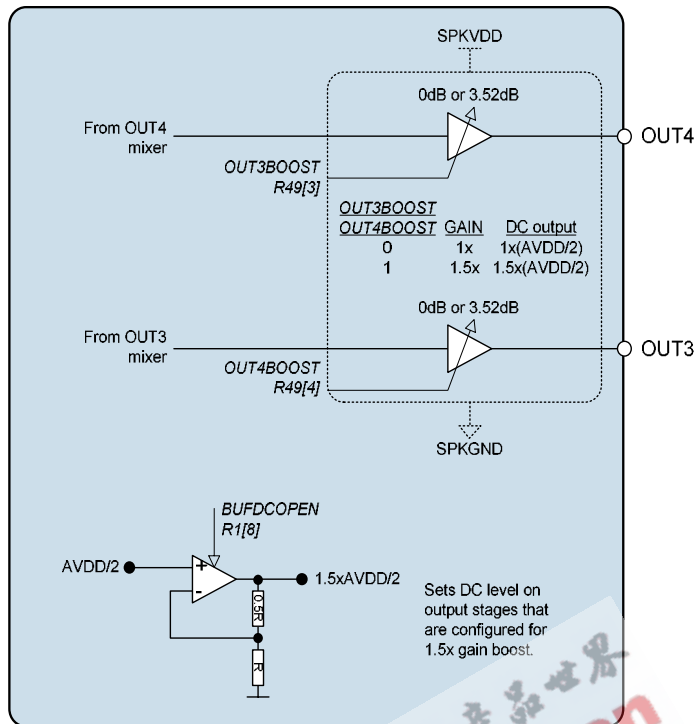

Figure 21 Outputs OUT3 and OUT4

REGISTER ADDRESS	BIT	LABEL	DEFAULT	DESCRIPTION
R49 Output control	3	OUT3BOOST	0	0 = OUT3 output gain = -1; DC = AVDD / 2 1 = OUT3 output gain = +1.5 DC = 1.5 x AVDD / 2
	4	OUT4BOOST	0	0 = OUT4 output gain = -1; DC = AVDD / 2 1 = OUT4 output gain = +1.5 DC = 1.5 x AVDD / 2
R1 Power management 1	8	BUFDCOPEN	0	Dedicated buffer for DC level shifting output stages when in 1.5x gain boost configuration. 0=Buffer disabled 1=Buffer enabled (required for 1.5x gain boost)

Table 38 OUT3 and OUT4 Boost Stages Control

OUT3BOOST/ OUT4BOOST	OUTPUT STAGE GAIN	OUTPUT DC LEVEL	OUTPUT STAGE CONFIGURATION
0	1x	AVDD/2	Inverting
1	1.5x	1.5xAVDD/2	Non-inverting

Table 39 OUT3/OUT4 Output Boost Stage Details

ENABLING THE OUTPUTS

Each analogue output of the WM8980 can be separately enabled or disabled. The analogue mixer associated with each output has a separate enable. All outputs are disabled by default. To save power, unused parts of the WM8980 should remain disabled.

Outputs can be enabled at any time, but it is not recommended to do so when BUFIO is disabled (BUFIOEN=0) or when BUFDCOP is disabled (BUFDCOPEN=0) when configured in output boost mode, as this may cause pop noise (see "Power Management" and "Applications Information" sections).

REGISTER ADDRESS	BIT	LABEL	DEFAULT	DESCRIPTION
R1 Power Management 1	2	BUFIOEN	0	Unused input/output tie off buffer enable
	6	OUT3MIXEN	0	OUT3 mixer enable
	7	OUT4MIXEN	0	OUT4 mixer enable
	8	BUFDCOPEN	0	Output stage 1.5xAVDD/2 driver enable
R2 Power Management 2	8	ROUT1EN	0	ROUT1 output enable
	7	LOUT1EN	0	LOUT1 output enable
	6	SLEEP	0	0 = normal device operation 1 = residual current reduced in device standby mode
R3 Power Management 3	2	LMIXEN	0	Left mixer enable
	3	RMIXEN	0	Right mixer enable
	4	VBUFEN	0	Video buffer enable
	5	ROUT2EN	0	ROUT2 output enable
	6	LOUT2EN	0	LOUT2 output enable
	7	OUT3EN	0	OUT3 enable
	8	OUT4EN	0	OUT4 enable
Note: All "Enable" bits are 1 = ON, 0 = OFF				

Table 40 Output Stages Power Management Control

THERMAL SHUTDOWN

The speaker outputs can drive very large currents. To protect the WM8980 from overheating a thermal shutdown circuit is included. If the device temperature reaches approximately 125°C and the thermal shutdown circuit is enabled (TSDEN=1) then the speaker amplifiers will be disabled if TSDEN is set. The thermal shutdown may also be configured to generate an interrupt. See the GPIO and Interrupt Controller section for details.

REGISTER ADDRESS	BIT	LABEL	DEFAULT	DESCRIPTION
R49 Output control	1	TSDEN	1	Thermal Shutdown Enable 0 : thermal shutdown disabled 1 : thermal shutdown enabled

Table 41 Thermal Shutdown

UNUSED ANALOGUE INPUTS/OUTPUTS

Whenever an analogue input/output is disabled, it remains connected to a voltage source (either AVDD/2 or 1.5xAVDD/2 as appropriate) through a resistor. This helps to prevent pop noise when the output is re-enabled. The resistance between the voltage buffer and the output pins can be controlled using the VROI control bit. The default impedance is low, so that any capacitors on the outputs can charge up quickly at start-up. If a high impedance is desired for disabled outputs, VROI can then be set to 1, increasing the resistance to about 30kΩ.

REGISTER ADDRESS	BIT	LABEL	DEFAULT	DESCRIPTION
R49	0	VROI	0	VREF (AVDD/2 or 1.5xAVDD/2) to analogue output resistance 0: approx 1kΩ 1: approx 30 kΩ

Table 42 Disabled Outputs to VREF Resistance

A dedicated buffer is available for tying off unused analogue I/O pins as shown in Figure 22. This buffer can be enabled using the BUFIOEN register bit.

If the SPKBOOST, OUT3BOOST or OUT4BOOST bits are set then the relevant outputs will be tied to the output of the DC level shift buffer at $1.5 \times AVDD/2$ when disabled.

Figure 22 summarises the tie-off options for the speaker and mono output pins.

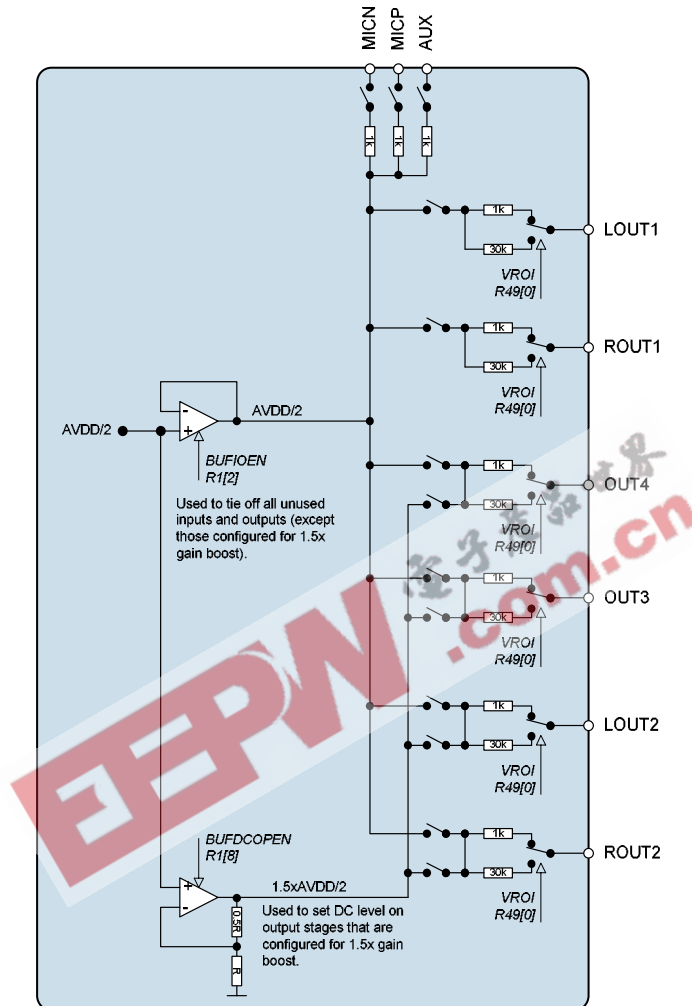

Figure 22 Unused Input/Output Pin Tie-off Buffers

L/ROUT2EN/ OUT3/4EN	OUT3BOOST/ OUT4BOOST/ SPKBOOST	VROI	OUTPUT CONFIGURATION
0	0	0	1kΩ tie-off to AVDD/2
0	0	1	30kΩ tie-off to AVDD/2
0	1	0	1kΩ tie-off to $1.5 \times AVDD/2$
0	1	1	30kΩ tie-off to $1.5 \times AVDD/2$
1	0	X	Output enabled (DC level=AVDD/2)
1	1	X	Output enabled (DC level= $1.5 \times AVDD/2$)

Table 43 Unused Output Pin Tie-off Options

VIDEO BUFFER

DESCRIPTION

The WM8980 incorporates a current mode output video buffer capable of operating from a 2.5V supply, with an input 3rd order Low Pass Filter (LPF) and clamp. The gain through this buffer can be programmed as 0dB or 6dB via the control interface. The current mode output means that the signal swing seen at the output of the buffer will be the same as that at the connection to the receiving equipment (e.g. a TV). Note that the input to the receiver should be AC coupled and terminated to 75Ω, as is standard, for best performance.

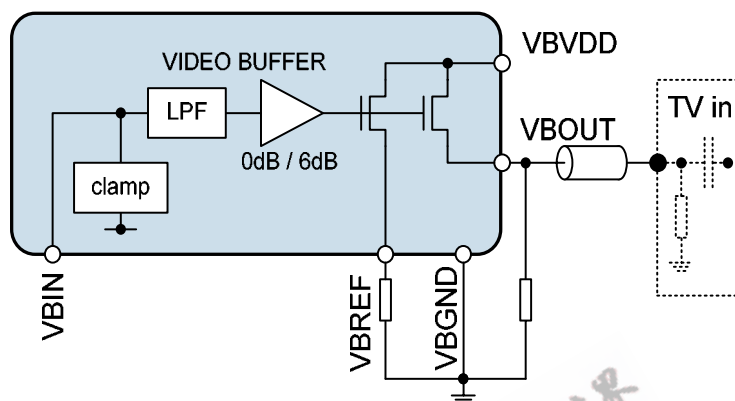

Figure 23 Video Buffer

The input clamp should be enabled when using AC coupling at the input to the video buffer, using the VBCLAMPEN register bit.

Care should be taken with PCB layout, designing for at least 1GHz frequencies to avoid degrading performance. Vias and sharp corners should be avoided and parasitic capacitance minimised on signal paths, which should be kept as short and straight as possible. The VBDD supply should be decoupled as close to the pin as possible. See the "External Components" section for more information.

LOW PASS FILTER

A low pass filter is integrated at the video buffer input, which is intended to remove images in the video DAC output waveform at multiples of the DAC clock frequency. A 3rd order Butterworth filter is used, with the following characteristics:

VIDEO BUFFER REGISTERS

Video buffer enable / disable and gain are controlled via the following registers:

REGISTER ADDRESS	BIT	LABEL	DEFAULT	DESCRIPTION
R3 Power management 3	4	VBUFEN	0	Video buffer enable 0 = enabled 1 = disabled
R40 Video Buffer	8	VBGAIN	0	Video buffer gain 0 = 0dB 1 = +6dB
	7	VBCLAMPEN	0	Video buffer clamp enable 0 = disabled 1 = enabled

Table 44 Video Buffer Registers

DIGITAL AUDIO INTERFACES

The audio interface has four pins:

- ADCDAT: ADC data output
- DACDAT: DAC data input
- LRC: Data Left/Right alignment clock
- BCLK: Bit clock, for synchronisation

The clock signals BCLK, and LRC can be outputs when the WM8980 operates as a master, or inputs when it is a slave (see Master and Slave Mode Operation, below).

Five different audio data formats are supported:

- Left justified
- Right justified
- I^2S
- DSP mode A
- DSP mode B

All of these modes are MSB first. They are described in Audio Data Formats, below. Refer to the Electrical Characteristic section for timing information.

MASTER AND SLAVE MODE OPERATION

The WM8980 audio interface may be configured as either master or slave. As a master interface device the WM8980 generates BCLK and LRC and thus controls sequencing of the data transfer on ADCDAT and DACDAT. To set the device to master mode register bit MS should be set high. In slave mode (MS=0), the WM8980 responds with data to clocks it receives over the digital audio interfaces.

AUDIO DATA FORMATS

In Left Justified mode, the MSB is available on the first rising edge of BCLK following an LRC transition. The other bits up to the LSB are then transmitted in order. Depending on word length, BCLK frequency and sample rate, there may be unused BCLK cycles before each LRC transition.

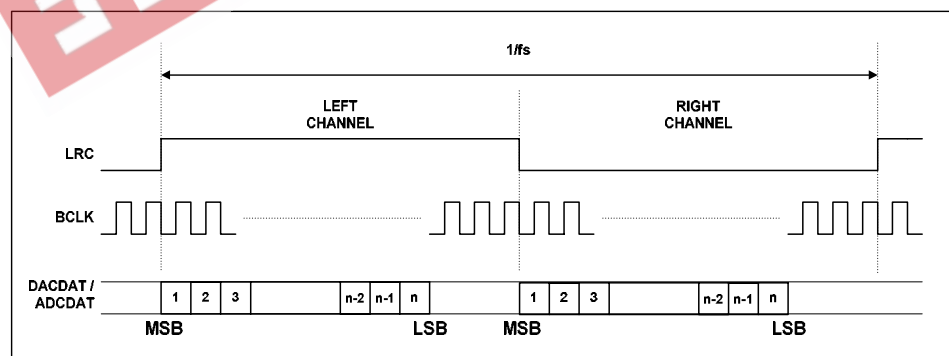

Figure 24 Left Justified Audio Interface (assuming n-bit word length)

In Right Justified mode, the LSB is available on the last rising edge of BCLK before a LRC transition. All other bits are transmitted before (MSB first). Depending on word length, BCLK frequency and sample rate, there may be unused BCLK cycles after each LRC transition.

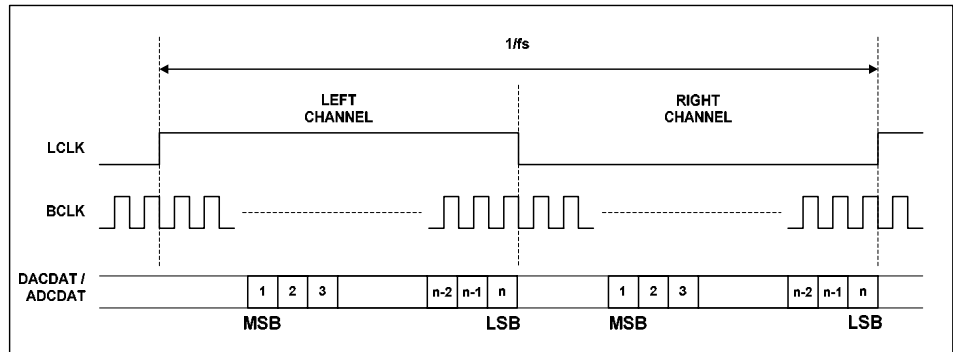

Figure 25 Right Justified Audio Interface (assuming n-bit word length)

In I²S mode, the MSB is available on the second rising edge of BCLK following a LRC transition. The other bits up to the LSB are then transmitted in order. Depending on word length, BCLK frequency and sample rate, there may be unused BCLK cycles between the LSB of one sample and the MSB of the next.

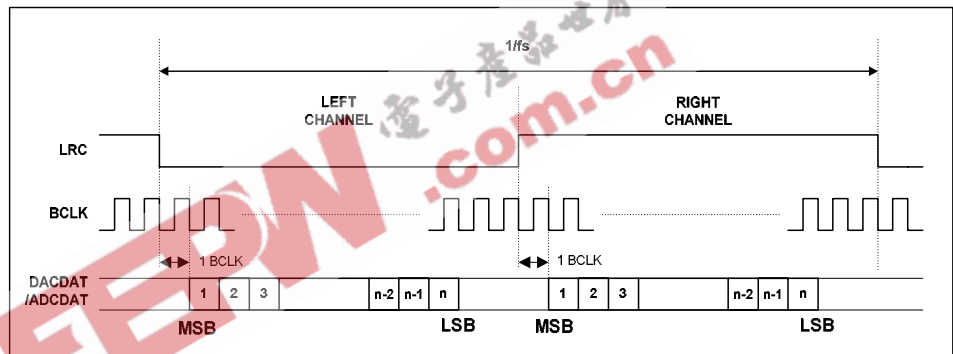

Figure 26 I²S Audio Interface (assuming n-bit word length)

In DSP/PCM mode, the left channel MSB is available on either the 1st (mode B) or 2nd (mode A) rising edge of BCLK (selectable by LRP) following a rising edge of LRC. Right channel data immediately follows left channel data. Depending on word length, BCLK frequency and sample rate, there may be unused BCLK cycles between the LSB of the right channel data and the next sample.

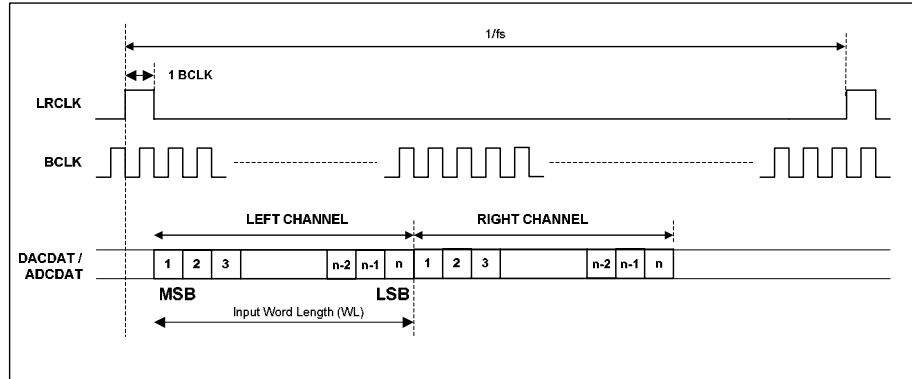

Figure 27 DSP/PCM Mode Audio Interface (mode A, LCRP=0)

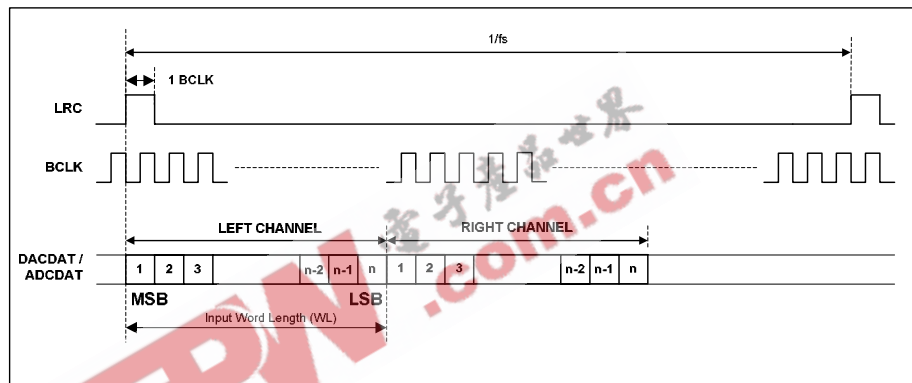

Figure 28 DSP/PCM Mode Audio Interface (mode B, LCRP=1)

REGISTER ADDRESS	BIT	LABEL	DEFAULT	DESCRIPTION
R4 Audio Interface Control	0	MONO	0	Selects between stereo and mono device operation: 0=Stereo device operation 1=Mono device operation. Data appears in 'left' phase of LRC
	1	ADCLRSWAP	0	Controls whether ADC data appears in 'right' or 'left' phases of LRC clock: 0=ADC data appear in 'left' phase of LRC 1=ADC data appears in 'right' phase of LRC
	2	DACLRSWAP	0	Controls whether DAC data appears in 'right' or 'left' phases of LRC clock: 0=DAC data appear in 'left' phase of LRC 1=DAC data appears in 'right' phase of LRC
	4:3	FMT	10	Audio interface Data Format Select: 00=Right Justified 01=Left Justified 10=I ² S format 11= DSP/PCM mode
	6:5	WL	10	Word length 00=16 bits 01=20 bits 10=24 bits 11=32 bits (see note)
	7	LRCP		LRC clock polarity 0=normal 1=inverted
	8	BCLP		BCLK polarity 0=normal 1=inverted

Table 45 Audio Interface Control

Note: Right Justified Mode will only operate with a maximum of 24 bits.

AUDIO INTERFACE CONTROL

The register bits controlling audio format, word length and master / slave mode are summarised below. Each audio interface can be controlled individually.

Register bit MS selects audio interface operation in master or slave mode. In Master mode BCLK, and LRC are outputs. The frequency of BCLK in master mode are controlled with BCLKDIV. These are divided down versions of master clock. This may result in short BCLK pulses at the end of a LRC if there is a non-integer ratio of BCLKs to LRC clocks.

REGISTER ADDRESS	BIT	LABEL	DEFAULT	DESCRIPTION
R6 Clock Generation Control	0	MS	0	Sets the chip to be master over LRC and BCLK 0=BCLK and LRC clock are inputs 1=BCLK and LRC clock are outputs generated by the WM8980 (MASTER)
	4:2	BCLKDIV	000	Configures the BCLK output frequency, for use when the chip is master over BCLK. 000=divide by 1 (BCLK=MCLK) 001=divide by 2 (BCLK=MCLK/2) 010=divide by 4 011=divide by 8 100=divide by 16 101=divide by 32 110=reserved 111=reserved
	7:5	MCLKDIV	010	Sets the scaling for either the MCLK or PLL clock output (under control of CLKSEL) 000=divide by 1 001=divide by 1.5 010=divide by 2 011=divide by 3 100=divide by 4 101=divide by 6 110=divide by 8 111=divide by 12
	8	CLKSEL	1	Controls the source of the clock for all internal operation: 0=MCLK 1=PLL output

Table 46 Clock Control

LOOPBACK

Setting the LOOPBACK register bit enables digital loopback. When this bit is set the output data from the ADC audio interface is fed directly into the DAC data input.

COMPANDING

The WM8980 supports A-law and μ -law and companding and linear mode on both transmit (ADC) and receive (DAC) sides. Companding can be enabled on the DAC or ADC audio interfaces by writing the appropriate value to the DAC_COMP or ADC_COMP register bits respectively.

REGISTER ADDRESS	BIT	LABEL	DEFAULT	DESCRIPTION
R5 Companding Control	0	LOOPBACK	0	Digital loopback function 0=No loopback 1=Loopback enabled, ADC data output is ded directly into DAC data input.
	2:1	ADC_COMP	0	ADC companding 00=off (linear mode) 01=reserved 10= μ -law 11=A-law
	4:3	DAC_COMP	0	DAC companding 00=off (linear mode) 01=reserved 10= μ -law 11=A-law
	5	WL8	0	0=off 1=device operates in 8-bit mode

Table 47 Companding Control

Companding involves using a piecewise linear approximation of the following equations (as set out by ITU-T G.711 standard) for data compression:

μ -law (where $\mu=255$ for the U.S. and Japan):

$$F(x) = \ln(1 + \mu|x|) / \ln(1 + \mu) \quad -1 \leq x \leq 1$$

A-law (where $A=87.6$ for Europe):

$$F(x) = A|x| / (1 + \ln A) \quad \text{for } x \leq 1/A$$

$$F(x) = (1 + \ln A|x|) / (1 + \ln A) \quad \text{for } 1/A \leq x \leq 1$$

The companded data is also inverted as recommended by the G.711 standard (all 8 bits are inverted for μ -law, all even data bits are inverted for A-law). The data will be transmitted as the first 8 MSB's of data.

Companding converts 13 bits (μ -law) or 12 bits (A-law) to 8 bits using non-linear quantization. The input data range is separated into 8 levels, allowing low amplitude signals better precision than that of high amplitude signals. This is to exploit the operation of the human auditory system, where louder sounds do not require as much resolution as quieter sounds. The companded signal is an 8-bit word containing sign (1-bit), exponent (3-bits) and mantissa (4-bits).

Setting the WL8 register bit allows the device to operate with 8-bit data. In this mode it is possible to use 8 BCLK's per LRC frame. When using DSP mode B, this allows 8-bit data words to be output consecutively every 8 BCLK's and can be used with 8-bit data words using the A-law and μ -law companding functions.

BIT8	BIT[7:4]	BIT[3:0]
SIGN	EXPONENT	MANTISSA

Table 48 8-bit Companded Word Composition

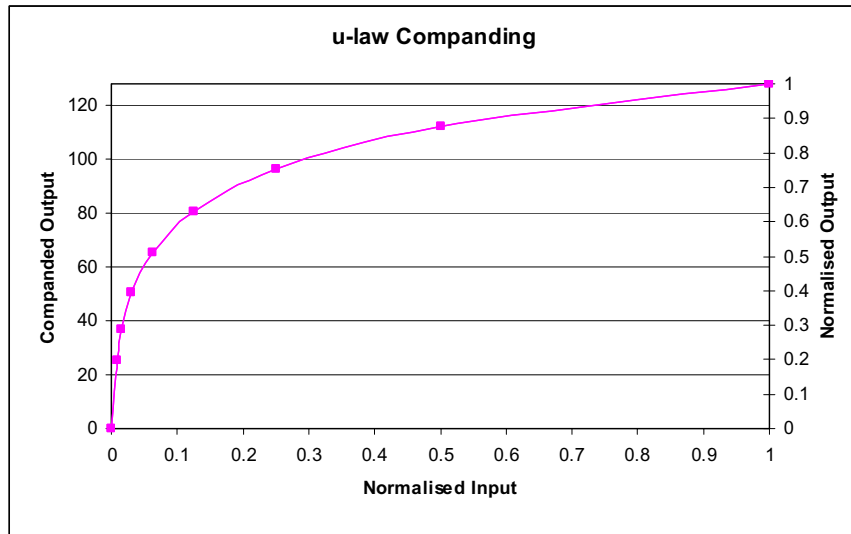

Figure 29 u-Law Companding

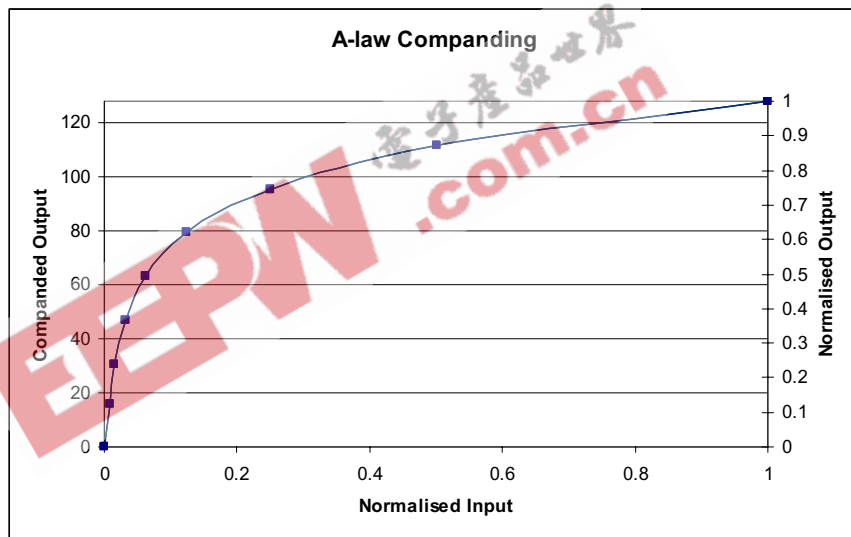

Figure 30 A-Law Companding

AUDIO SAMPLE RATES

The WM8980 sample rates for the ADCs and the DACs are set using the SR register bits. The cutoffs for the digital filters and the ALC attack/decay times stated are determined using these values and assume a 256fs master clock rate.

If a sample rate that is not explicitly supported by the SR register settings is required then the closest SR value to that sample rate should be chosen, the filter characteristics and the ALC attack, decay and hold times will scale appropriately.

REGISTER ADDRESS	BIT	LABEL	DEFAULT	DESCRIPTION
R7 Additional Control	3:1	SR	000	Approximate sample rate (configures the coefficients for the internal digital filters): 000=48kHz 001=32kHz 010=24kHz 011=16kHz 100=12kHz 101=8kHz 110-111=reserved

Table 49 Sample Rate Control

MASTER CLOCK AND PHASE LOCKED LOOP (PLL)

The WM8980 has an on-chip phase-locked loop (PLL) circuit that can be used to:

Generate master clocks for the WM8980 audio functions from another external clock, e.g. in telecoms applications.

Generate and output (on pin CSB/GPIO1 and/or GPIO4) a clock for another part of the system that is derived from an existing audio master clock.

Figure 31 shows the PLL and internal clocking arrangement on the WM8980.

The PLL can be enabled or disabled by the PLEN register bit.

REGISTER ADDRESS	BIT	LABEL	DEFAULT	DESCRIPTION
R1 Power management 1	5	PLEN	0	PLL enable 0=PLL off 1=PLL on

Table 50 PLEN Control Bit

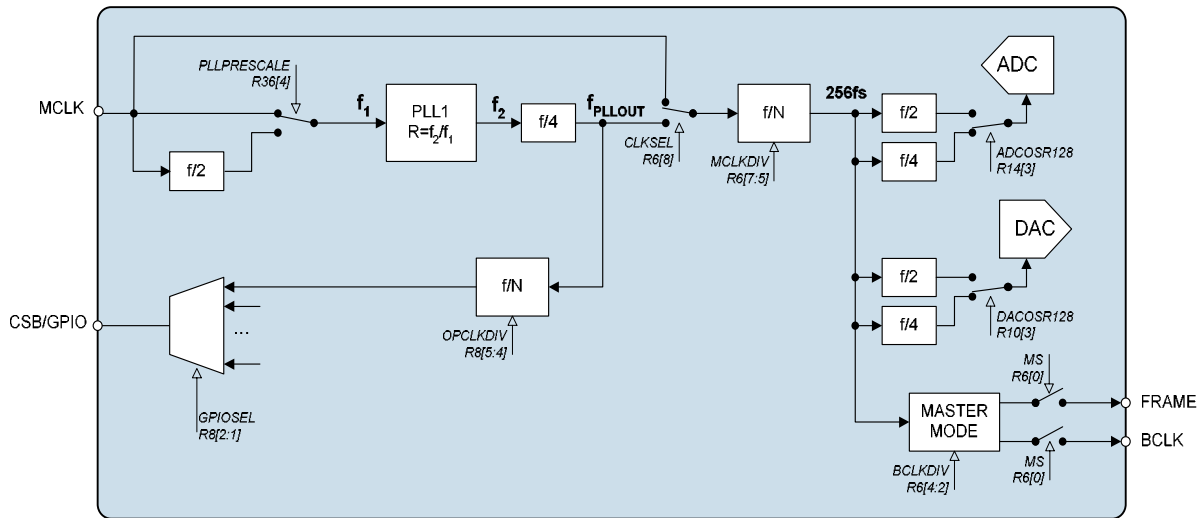

Figure 31 PLL and Clock Select Circuit

The PLL frequency ratio $R = f_2/f_1$ (see Figure 31) can be set using the register bits PLLK and PLLN:

$$PLL N = \text{int } R$$

$$PLL K = \text{int } (2^{24} (R - PLLN))$$

EXAMPLE:

MCLK=12MHz, required clock = 12.288MHz.

R should be chosen to ensure $5 < PLLN < 13$. There is a fixed divide by 4 in the PLL and a selectable divide by N after the PLL which should be set to divide by 2 to meet this requirement.

Enabling the divide by 2 sets the required $f_2 = 4 \times 2 \times 12.288\text{MHz} = 98.304\text{MHz}$.

$$R = 98.304 / 12 = 8.192$$

$$PLL N = \text{int } R = 8$$

$$k = \text{int } (2^{24} \times (8.192 - 8)) = 3221225 = 3126E9h$$

REGISTER ADDRESS	BIT	LABEL	DEFAULT	DESCRIPTION
R36 PLL N value	4	PLLPRESCALE	0	Divide MCLK by 2 before input to PLL
	3:0	PLLN	1000	Integer (N) part of PLL input/output frequency ratio. Use values greater than 5 and less than 13.
R37 PLL K value 1	5:0	PLLK [23:18]	0Ch	Fractional (K) part of PLL1 input/output frequency ratio (treat as one 24-digit binary number).
R38 PLL K Value 2	8:0	PLLK [17:9]	093h	
R39 PLL K Value 3	8:0	PLLK [8:0]	0E9h	

Table 51 PLL Frequency Ratio Control

The PLL performs best when f_2 is around 90MHz. Its stability peaks at N=8. Some example settings are shown in Table 52.

MCLK (MHz) (F1)	DESIRED OUTPUT (MHz)	F2 (MHz)	PRESCALE DIVIDE	POSTSCALE DIVIDE	R	N (Hex)	K (Hex)
12	11.29	90.3168	1	2	7.5264	7	86C227
12	12.288	98.304	1	2	8.192	8	3126E9
13	11.29	90.3168	1	2	6.947446	6	F28BD5
13	12.288	98.304	1	2	7.561846	7	8FD526
14.4	11.29	90.3168	1	2	6.272	6	45A1CB
14.4	12.288	98.304	1	2	6.826667	6	D3A06D
19.2	11.29	90.3168	2	2	9.408	9	6872B0
19.2	12.288	98.304	2	2	10.24	A	3D70A4
19.68	11.29	90.3168	2	2	9.178537	9	2DB493
19.68	12.288	98.304	2	2	9.990243	9	FD80A0
19.8	11.29	90.3168	2	2	9.122909	9	1F76F8
19.8	12.288	98.304	2	2	9.929697	9	EE009F
24	11.29	90.3168	2	2	7.5264	7	86C227
24	12.288	98.304	2	2	8.192	8	3126E9
26	11.29	90.3168	2	2	6.947446	6	F28BD5
26	12.288	98.304	2	2	7.561846	7	8FD526
27	11.29	90.3168	2	2	6.690133	6	BOAC94
27	12.288	98.304	2	2	7.281778	7	482297
12	11.29	90.3168	1	2	7.5264	7	86C227
12	12.288	98.304	1	2	8.192	8	3126E9

Table 52 PLL Frequency Examples

GENERAL PURPOSE INPUT/OUTPUT

The WM8980 has three dual purpose input/output pins and one dedicated GPIO.

- CSB/GPIO1: CSB / GPIO pin
- L2/GPIO2: Left channel line input / headphone detection input
- R2/GPIO3: Right channel line input / headphone detection input
- GPIO4: Dedicated GPIO

The GPIO2 and GPIO3 functions are provided for use as jack detection inputs.

The GPIO1 and GPIO4 functions are provided for use as jack detection inputs or general purpose outputs.

The default configuration for the CSB/GPIO1 and GPIO4 pins are to be inputs.

When setup as an input, the CSB/GPIO1 pin can either be used as CSB or for jack detection, depending on how the MODE pin is set.

If setup as an input the GPIO4 pin can also be used for jack detection.

Table 49 illustrates the functionality of the GPIO1 and GPIO4 pins when used as general purpose outputs.

REGISTER ADDRESS	BIT	LABEL	DEFAULT	DESCRIPTION
R8 GPIO Control	2:0	GPIO1SEL	000	CSB/GPIO1 pin function select: 000= input (CSB/jack detection: depending on MODE setting) 001= reserved 010=Temp ok 011=Amute active 100=PLL clk o/p 101=PLL lock 110=logic 1 111=logic 0
	3	GPIO1POL	0	GPIO1 Polarity invert 0=Non inverted 1=Inverted
	5:4	OPCLKDIV	00	PLL Output clock division ratio 00=divide by 1 01=divide by 2 10=divide by 3 11=divide by 4
R9 GPIO Control	2:0	GPIO4SEL	000	GPIO4 pin function select: 000= input jack detection 001= reserved 010=Temp ok 011=Amute active 100=PLL clk o/p 101=PLL lock 110=logic 1 111=logic 0
	3	GPIO4POL	0	GPIO4 Polarity invert 0=Non inverted 1=Inverted

Table 53 CSB/GPIO Control

Note: If MODE is set to 3 wire mode, CSB/GPIO1 shall be used as CSB input irrespective of the GPIO1SEL[2:] bits.

For further details of the Jack detect operation see the OUTPUT SWITCHING section.

OUTPUT SWITCHING (JACK DETECT)

When the device is configured with a 2-wire interface the CSB/GPIO1 pin can be used as a switch control input to automatically disable one set of outputs and enable another. The L2/GPIO2, R2/GPIO3 and GPIO4 pins can also be used for this purpose. For example, when a headphone is plugged into a jack socket then it may be desirable to disable the speaker (e.g. when one of the GPIO pins is connected to a mechanical switch in the headphone socket to detect plug-in).

The GPIO pins have an internal de-bounce circuit when in this mode in order to prevent the output enables from toggling multiple times due to input glitches. This de-bounce circuit is clocked from a slow clock with period $2^{21} \times \text{MCLK}$.

Note that the GPIOPOL bits are not relevant for jack detection, it is the signal detected at the pin which is used.

The switching on/off of the outputs is fully configurable by the user. Each output, OUT1, OUT2, OUT3 and OUT4 has 2 associated enables. OUT1_EN_0, OUT2_EN_0, OUT3_EN_0 and OUT4_EN_0 are the output enable signal which are used if the selected jack detection pin is at logic 0 (after de-bounce). OUT1_EN_1, OUT2_EN_1, OUT3_EN_1 and OUT4_EN_1 are the output enable signals which are used if the selected jack detection pin is at logic 1 (after de-bounce).

Similar to the output enables, VMID, which can be driven out of OUT3 can be configured to be on/off depending on the jack detection input polarity using the VMID_EN_0 and VMID_EN_1 bits.

The jack detection enables work as follows:

All OUT_EN signals have an AND function performed with their normal enable signals (in Table 40). When an output is normally enabled at per Table 40, the selected jack detection enable (controlled by selected jack detection pin polarity) is set 0, it will turn the output off. If the normal enable signal is already OFF (0), the jack detection signal will have no effect due on the AND function.

During jack detection if the user desires an output to be un-changed whether the jack is in or not, both the JD_EN settings i.e. JD_EN0 and JD_EN1, should be set to 0000.

The VMID_EN signal has an OR function performed with the normal VMID driver enable. If the VMID_EN signal is to have no effect to normal functionality when jack detection is enabled, it should set to 0 for all JD_EN0 or JD_EN1 settings.

If jack detection is not enabled (JD_EN=0), the output enables default to all 1's, allowing the outputs to be controlled as normal via the normal output enables found in Table 40. Similarly the VMID_EN signal defaults to 0 allowing the VMID driver to be controlled via the normal enable bit.

REGISTER ADDRESS	BIT	LABEL	DEFAULT	DESCRIPTION
R9 GPIO Control	5:4	JD_SEL	00	Pin selected as jack detection input 00 = GPIO1 01 = GPIO2 10 = GPIO3 11 = GPIO4
	6	JD_EN	0	Jack Detection Enable 0=disabled 1=enabled
	8:7	JD_VMID	00	[7] VMID_EN_0 [8] VMID_EN_1
R13 GPW Control	3:0	JD_EN0	0	Output enabled when selected jack detection input is logic 0. [0]= OUT1_EN_0 [1]= OUT2_EN_0 [2]= OUT3_EN_0 [3]= OUT4_EN_0
	7:4	JD_EN1	0	Output enabled when selected jack detection input is logic 1 [4]= OUT1_EN_1 [5]= OUT2_EN_1 [6]= OUT3_EN_1 [7]= OUT4_EN_1

Table 54 Jack Detect Register Control Bits

CONTROL INTERFACE

SELECTION OF CONTROL MODE AND 2-WIRE MODE ADDRESS

The control interface can operate as either a 3-wire or 2-wire MPU interface. The MODE pin determines the 2 or 3 wire mode as shown in Table 55.

The WM8980 is controlled by writing to registers through a serial control interface. A control word consists of 16 bits. The first 7 bits (B15 to B9) are address bits that select which control register is accessed. The remaining 9 bits (B8 to B0) are register bits, corresponding to the 9 bits in each control register.

MODE	INTERFACE FORMAT
Low	2 wire
High	3 wire

Table 55 Control Interface Mode Selection

3-WIRE SERIAL CONTROL MODE

In 3-wire mode, every rising edge of SCLK clocks in one data bit from the SDIN pin. A rising edge on CSB/GPIO1 pin latches in a complete control word consisting of the last 16 bits.

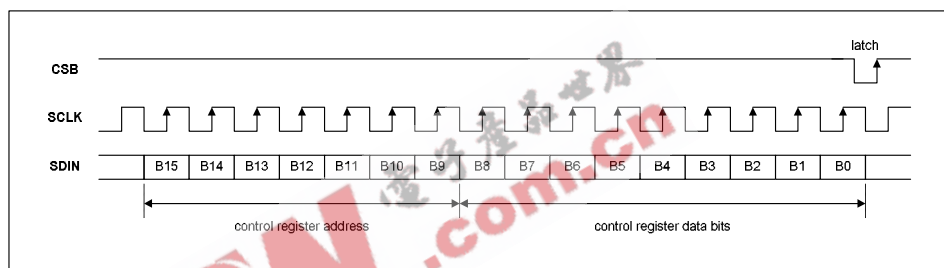

Figure 32 3-Wire Serial Control Interface

2-WIRE SERIAL CONTROL MODE

The WM8980 supports software control via a 2-wire serial bus. Many devices can be controlled by the same bus, and each device has a unique 7-bit device address (this is not the same as the 7-bit address of each register in the WM8980).

The WM8980 operates as a slave 2-wire device only. The controller indicates the start of data transfer with a high to low transition on SDIN while SCLK remains high. This indicates that a device address and data will follow. All devices on the 2-wire bus respond to the start condition and shift in the next eight bits on SDIN (7-bit address + Read/Write bit, MSB first). If the device address received matches the address of the WM8980, then the WM8980 responds by pulling SDIN low on the next clock pulse (ACK). If the address is not recognised or the R/W bit is '1' when operating in write only mode, the WM8980 returns to the idle condition and wait for a new start condition and valid address.

During a write, once the WM8980 has acknowledged a correct address, the controller sends the first byte of control data (B15 to B8, i.e. the WM8980 register address plus the first bit of register data). The WM8980 then acknowledges the first data byte by pulling SDIN low for one clock pulse. The controller then sends the second byte of control data (B7 to B0, i.e. the remaining 8 bits of register data), and the WM8980 acknowledges again by pulling SDIN low.

Transfers are complete when there is a low to high transition on SDIN while SCLK is high. After a complete sequence the WM8980 returns to the idle state and waits for another start condition. If a start or stop condition is detected out of sequence at any point during data transfer (i.e. SDIN changes while SCLK is high), the device jumps to the idle condition.

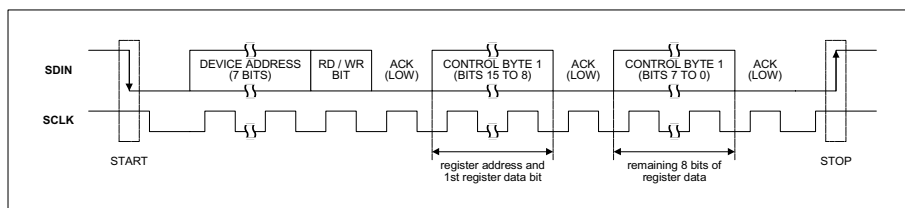

Figure 33 2-Wire Serial Control Interface

In 2-wire mode the WM8980 has a fixed device address, 0011010.

RESETTING THE CHIP

The WM8980 can be reset by performing a write of any value to the software reset register (address 0 hex). This will cause all register values to be reset to their default values. In addition to this there is a Power-On Reset (POR) circuit which ensures that the registers are set to default when the device is powered up.

POWER SUPPLIES

The WM8980 can use up to five separate power supplies:

AVDD and AGND: Analogue supply, powers all analogue functions except the speaker output and mono output drivers. AVDD can range from 2.5V to 3.6V and has the most significant impact on overall power consumption (except for power consumed in the headphone). A large AVDD slightly improves audio quality.

SPKVDD and SPKGND: Headphone and Speaker supplies, power the speaker and mono output drivers. SPKVDD can range from 2.5V to 5V. SPKVDD can be tied to AVDD, but it requires separate layout and decoupling capacitors to curb harmonic distortion. With a larger SPKVDD, louder headphone and speaker outputs can be achieved with lower distortion. If SPKVDD is lower than AVDD, the output signal may be clipped.

DCVDD: Digital core supply, powers all digital functions except the audio and control interfaces. DCVDD can range from 1.62V to 3.6V, and has no effect on audio quality. The return path for DCVDD is DGND, which is shared with DBVDD.

DBVDD can range from 1.8V to 3.6V. DBVDD return path is through DGND.

VBVDD and VBGND: Supplies for video buffer circuit. VBVDD can range from 2.5V to 3.6V.

It is possible to use the same supply voltage for all four supplies. However, digital and analogue supplies should be routed and decoupled separately on the PCB to keep digital switching noise out of the analogue signal paths.

RECOMMENDED POWER UP/DOWN SEQUENCE

In order to minimise output 'pop' and 'click' noise it is recommended that the device is powered up in a controlled sequence.

In addition to this it is recommended that the zero cross functions are used when changing the volume in the PGAs.

POWER MANAGEMENT

SAVING POWER BY REDUCING OVERSAMPLING RATE

The default mode of operation of the ADC and DAC digital filters is in 64x oversampling mode. Under the control of ADCOSR and DACOSR the oversampling rate may be doubled. 64x oversampling results in a slight decrease in noise performance compared to 128x but lowers the power consumption of the device.

REGISTER ADDRESS	BIT	LABEL	DEFAULT	DESCRIPTION
R10 DAC control	3	DACOSR128	0	DAC oversample rate select 0 = 64x (lowest power) 1 = 128x (best SNR)
R14 ADC control	3	ADCOSR128	0	ADC oversample rate select 0 = 64x (lowest power) 1 = 128x (best SNR)

Table 56 ADC and DAC Oversampling Rate Selection

VMID

The analogue will not work unless VMID is enabled (VMIDSEL 00). The impedance of the VMID resistor string, together with the decoupling capacitor on the VMID pin will determine the startup time of the VMID circuit.

REGISTER ADDRESS	BIT	LABEL	DEFAULT	DESCRIPTION
R1 Power management 1	1:0	VMIDSEL	00	Reference string impedance to VMID pin (determines startup time): 00=off (open circuit) 01=75k Ω 10=300k Ω 11=5k Ω (for fastest startup)

Table 57 VMID Impedance Control

BIASEN

The analogue amplifiers will not operate unless BIASEN is enabled.

REGISTER ADDRESS	BIT	LABEL	DEFAULT	DESCRIPTION
R1 Power management 1	3	BIASEN	0	Analogue amplifier bias control

Table 58 Analogue Bias Control

ESTIMATED SUPPLY CURRENTS

When either the DAC or ADC are enabled it is estimated that approximately 4mA will be drawn from DCVDD when $f_s=48\text{kHz}$ (This will be lower at lower sample rates). When the PLL is enabled an additional 700 microamps will be drawn from DCVDD. It is anticipated that the video buffer will draw about 1mA with no load attached, in normal operating up to 30 mA will be drawn.

Table 53 shows the estimated 3.3V AVDD current drawn by various circuits, by register bit.

REGISTER BIT	AVDD CURRENT (MILLIAMPS)
BUFDCOPEN	0.1
OUT4MIXEN	0.2
OUT3MIXEN	0.2
PLLEN	1.4 (with clocks applied)
MICBEN	0.5
BIASEN	0.3
BUFIOEN	0.1
VMIDSEL	10K=>0.3, less than 0.1 for 100k/500k
ROUT1EN	0.4
LOUT1EN	0.4
BOOSTENR	0.2
BOOSTENL	0.2
INPPGAENR	0.2
INPPGAENL	0.2
ADCENR	x64 (ADCOSR=0)=>2.6, x128 (ADCOSR=1)=>4.9
ADCENL	x64 (ADCOSR=0)=>2.6, x128 (ADCOSR=1)=>4.9
OUT4EN	0.2
OUT3EN	0.2
LOUT2EN	1mA from SPKVDD + 0.2mA from AVDD in 5V mode
ROUT2EN	1mA from SPKVDD + 0.2mA from AVDD in 5V mode
RMIXEN	0.2
LMIXEN	0.2
DACENR	x64 (DACOSR=0)=>1.8, x128(DACOSR=1)=>1.9
DACENL	x64 (DACOSR=0)=>1.8, x128(DACOSR=1)=>1.9

Table 59 AVDD Supply Current

REGISTER MAP

ADDR B[15:9]	REGISTER NAME	B8	B7	B6	B5	B4	B3	B2	B1	B0	DEF'T VAL (HEX)	
DEC	HEX											
0	00	Software Reset										
1	01	Power manage't 1	BUFDCOP EN	OUT4MIX EN	OUT3MIX EN	PLLEN	MICBEN	BIASEN	BUFIOEN	VMIDSEL		000
2	02	Power manage't 2	ROUT1EN	LOUT1EN	SLEEP	OOSTENR	BOOSTENL	INPGAENR	NPPGAENL	ADCENR	ADCENL	000
3	03	Power manage't 3	OUT4EN	OUT3EN	LOUT2EN	ROUT2EN	VBUFEN	RMIXEN	LMIXEN	DACENR	DACENL	000
4	04	Audio Interface	BCP	LRCP	WL		FMT		DLRSWAP	ALRSWAP	MONO	050
5	05	Companding ctrl	0	0	0	WL8	DAC_COMP		ADC_COMP		LOOPBACK	000
6	06	Clock Gen ctrl	CLKSEL	MCLKDIV			BCLKDIV			0	MS	140
7	07	Additional ctrl	0	0	0	0	0	SR			LOWCLKEN	000
8	08	GPIO Stuff	0	0	0	OPCLKDIV		GPIO1POL	GPIO1SEL[2:0]			000
9	09	Jack detect control	JD_VMID1	JD_VMID0	JD_EN	JD_SEL		GPIO4POL	GPIO4SEL[2:0]			000
10	0A	DAC Control	0	0	SOFT MUTE	0	0	DACOSR 128	AMUTE	DACPOLR	DACPOLL	000
11	0B	Left DAC digital Vol	DACVU	DACVOLL								OFF
12	0C	Right DAC dig'l Vol	DACVU	DACVOLR								OFF
13	0D	ack Detect Control	JD_EN1				JD_EN0					000
14	0E	ADC Control	HPFEN	HPFAPP	HPFCUT			ADCOSR 128	0	ADCRPOL	ADCLPOL	100
15	0F	Left ADC Digital Vol	ADCVU	ADCVOLL								OFF
16	10	Right ADC Digital Vol	ADCVU	ADCVOLR								OFF
18	12	EQ1 – low shelf	EQ3DMODE	0	EQ1C			EQ1G				12C
19	13	EQ2 – peak 1	EQ2BW	0	EQ2C			EQ2G				02C
20	14	EQ3 – peak 2	EQ3BW	0	EQ3C			EQ3G				02C
21	15	EQ4 – peak 3	EQ4BW	0	EQ4C			EQ4G				02C
22	16	EQ5 – high shelf	0	0	EQ5C			EQ5G				02C
24	18	DAC Limiter 1	LIMEN	LIMDCY				LIMATK				032
25	19	DAC Limiter 2	0	0	LIMLVL			LIMBOOST				000
27	1B	Notch Filter 1	NFU	NFEN	NFA0[13:7]							000
28	1C	Notch Filter 2	NFU	0	NFA0[6:0]							000
29	1D	Notch Filter 3	NFU	0	NFA1[13:7]							000
30	1E	Notch Filter 4	NFU	0	NFA1[6:0]							000
32	20	ALC control 1	ALCSEL		0	ALCMAX			ALCMIN			038
33	21	ALC control 2	ALCZC	ALCHLD				ALCLVL				00B
34	22	ALC control 3	ALCMODE	ALCDCY				ALCATK				032
35	23	Noise Gate	0	0	0	0	0	NGEN	NGTH			000
36	24	PLL N	0	0	0	0	PLL_PRE SCALE	PLLN[3:0]				008
37	25	PLL K 1	0	0	0	PLLK[23:18]					00C	
38	26	PLL K 2	PLLK[17:9]									093
39	27	PLL K 3	PLLK[8:0]									0E9
40	28	Video Buffer	0	0	0	0	0	0	VBPULLDWN	VBGAIN	VBCLAMP EN	000
41	29	3D control	0	0	0	0	0	DEPTH3D				000
43	2B	Beep control	0	0	0	MUTER PGA2INV	INVROUT2	BEEPVOL			BEEPEN	000
44	2C	Input ctrl	MICBVSEL	0	R2_2 INPPGA	RIN2 INPPGA	RIP2 INPPGA	0	L2_2 INPPGA	LIN2 INPPGA	LIP2 INPPGA	003
45	2D	Left INP PGA gain ctrl	INPGA UPDATE	NPPGAZCL	INPPGA MUTEL	INPPGAVOLL					010	

46	2E	Right INP PGA gain ctrl	INPGA UPDATE	NPPGAZCR	INPPGA MUTER	INPPGAVOLR						010
47	2F	Left ADC Boost ctrl	PGABOOSTL	0	L2_2BOOSTVOL		0	AUXL2BOOSTVOL				100
48	30	Right ADC Boost ctrl	PGABOOSTR	0	R2_2BOOSTVOL		0	AUXR2BOOSTVOL				100
49	31	Output ctrl	0	0	DACL2 RMIX	DACR2 LMIX	OUT4 BOOST	OUT3 BOOST	SPKR BOOST	TSDEN	VROI	002
50	32	Left mixer ctrl	AUXLMIXVOL			AUXL2LMIX	BYPLMIXVOL			BYPL2LMIX	DACL2LMIX	001
51	33	Right mixer ctrl	AUXRMIXVOL			UXR2RMIX	BYPRMIXVOL			BYPR2RMIX	DACR2RMIX	001
52	34	LOUT1 (HP) volume ctrl	UPDATE	LOUT1ZC	LOUT1 MUTE	LOUT1VOL						039
53	35	ROUT1 (HP) volume ctrl	UPDATE	ROUT1ZC	ROUT1 MUTE	ROUT1VOL						039
54	36	LOUT2 (SPK) volume ctrl	UPDATE	LOUT2ZC	LOUT2 MUTE	LOUT2VOL						039
55	37	ROUT2 (SPK) volume ctrl	UPDATE	ROUT2ZC	ROUT2 MUTE	ROUT2VOL						039
56	38	OUT3 mixer ctrl	0	0	OUT3 MUTE	0	0	OUT4_2OUT3	BYPL2 OUT3	LMIX2 OUT3	LDAC2 OUT3	001
57	39	OUT4 (MONO) mixer ctrl	0	0	OUT4 MUTE	HALFSIG	LMIX2 OUT4	LDAC2 OUT4	BYPR2 OUT4	RMIX2 OUT4	RDAC2 OUT4	001

Table 60 WM8980 Register Map

DIGITAL FILTER CHARACTERISTICS

PARAMETER	TEST CONDITIONS	MIN	TYP	MAX	UNIT
ADC Filter					
Passband	+/- 0.025dB	0		0.454fs	
	-6dB		0.5fs		
Passband Ripple				+/- 0.025	dB
Stopband		0.546fs			
Stopband Attenuation	f > 0.546fs	-60			dB
Group Delay			21/fs		
ADC High Pass Filter					
High Pass Filter Corner Frequency	-3dB		3.7		Hz
	-0.5dB		10.4		
	-0.1dB		21.6		
DAC Filter					
Passband	+/- 0.035dB	0		0.454fs	
	-6dB		0.5fs		
Passband Ripple				+/-0.035	dB
Stopband		0.546fs			
Stopband Attenuation	f > 0.546fs	-80			dB
Group Delay			29/fs		

Table 61 Digital Filter Characteristics

TERMINOLOGY

1. Stop Band Attenuation (dB) – the degree to which the frequency spectrum is attenuated (outside audio band)
2. Pass-band Ripple – any variation of the frequency response in the pass-band region

DAC FILTER RESPONSES

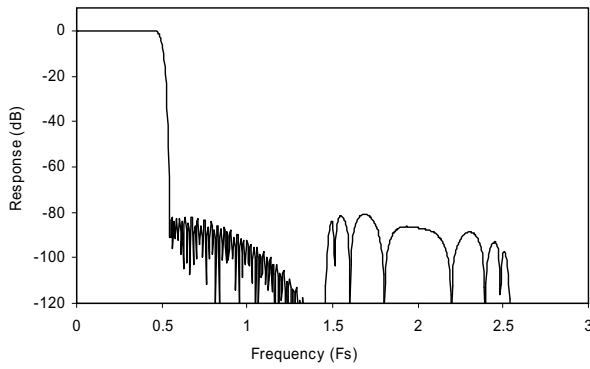

Figure 34 DAC Digital Filter Frequency Response

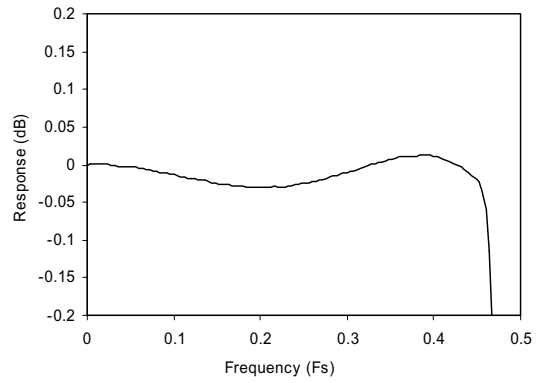

Figure 35 DAC Digital Filter Ripple

ADC FILTER RESPONSES

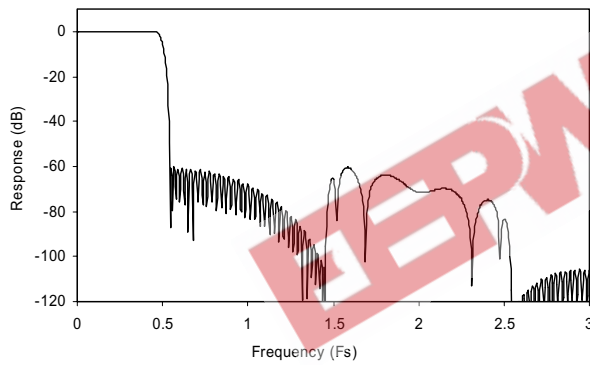

Figure 36 ADC Digital Filter Frequency Response

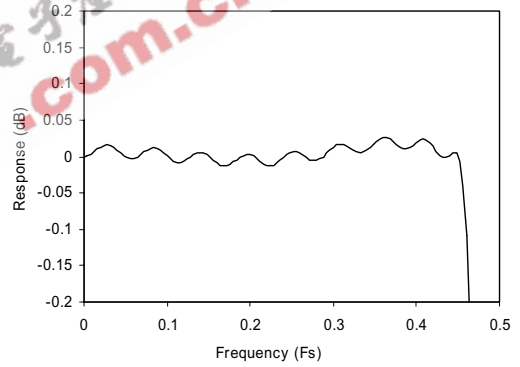

Figure 37 ADC Digital Filter Ripple

HIGHPASS FILTER

The WM8980 has a selectable digital highpass filter in the ADC filter path. This filter has two modes, audio and applications. In audio mode the filter is a 1st order IIR with a cut-off of around 3.7Hz. In applications mode the filter is a 2nd order high pass filter with a selectable cut-off frequency.

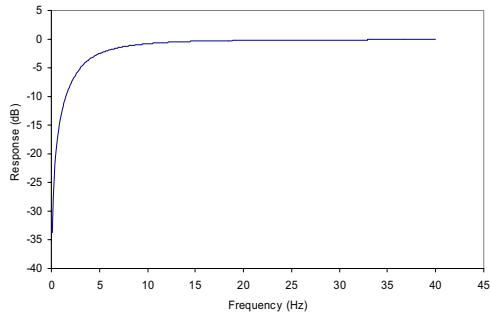

Figure 38 ADC Highpass Filter Response, HPFAPP=0

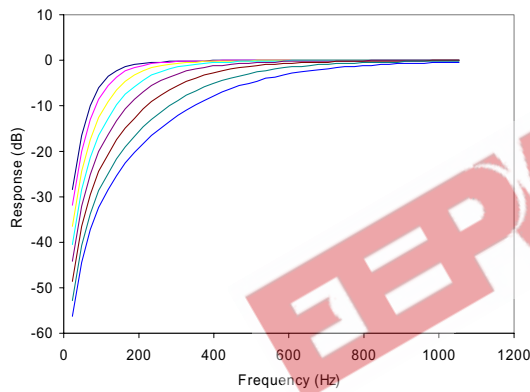

Figure 39 ADC Highpass Filter Responses (48kHz), HPFAPP=1, all cut-off settings shown.

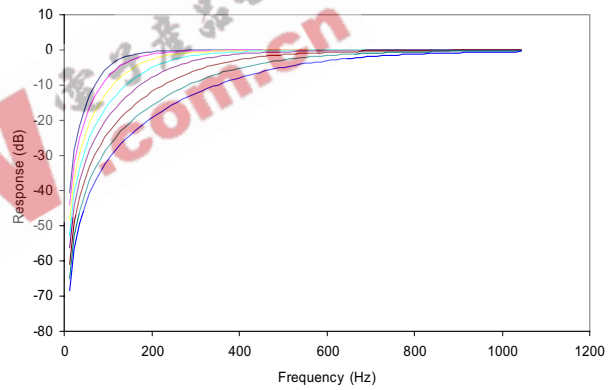

Figure 40 ADC Highpass Filter Responses (24kHz), HPFAPP=1, all cut-off settings shown.

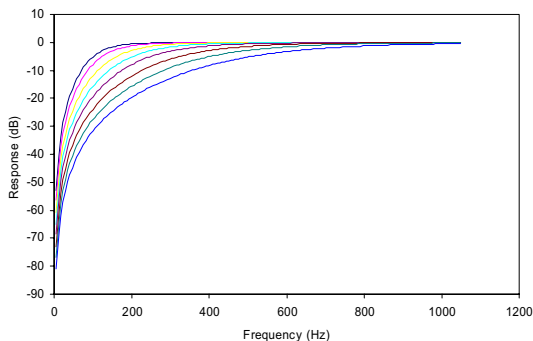

Figure 41 ADC Highpass Filter Responses (12kHz), HPFAPP=1, all cut-off settings shown.

5-BAND EQUALISER

The WM8980 has a 5-band equaliser which can be applied to either the ADC path or the DAC path. The plots from Figure 42 to Figure 55 show the frequency responses of each filter with a sampling frequency of 48kHz, firstly showing the different cut-off/centre frequencies with a gain of $\pm 12\text{dB}$, and secondly a sweep of the gain from -12dB to $+12\text{dB}$ for the lowest cut-off/centre frequency of each filter.

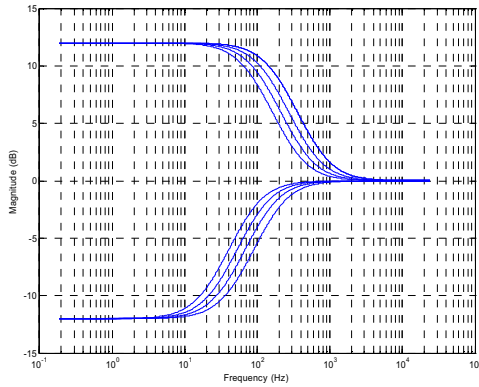

Figure 42 EQ Band 1 Low Frequency Shelf Filter Cut-offs

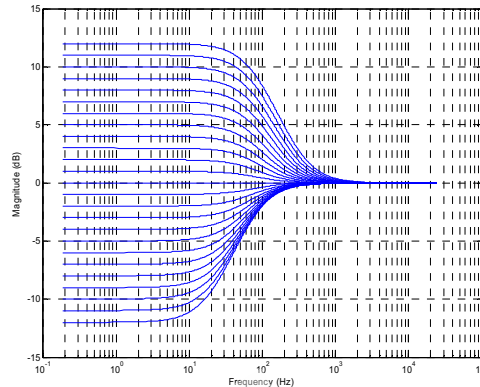

Figure 43 EQ Band 1 Gains for Lowest Cut-off Frequency

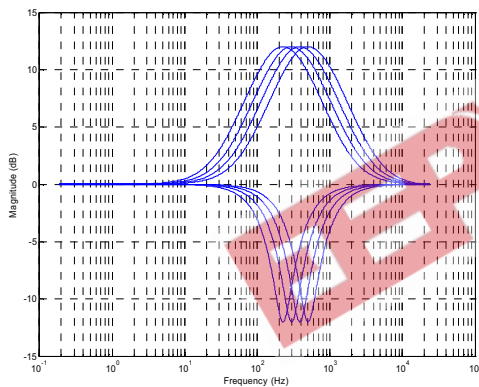

Figure 44 EQ Band 2 – Peak Filter Centre Frequencies, EQ2BW=0

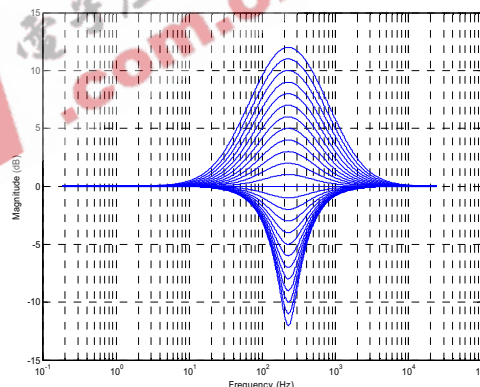

Figure 45 EQ Band 2 – Peak Filter Gains for Lowest Cut-off Frequency, EQ2BW=0

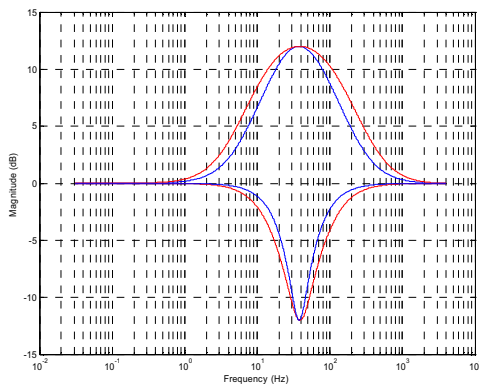

Figure 46 EQ Band 2 – EQ2BW=0, EQ2BW=1

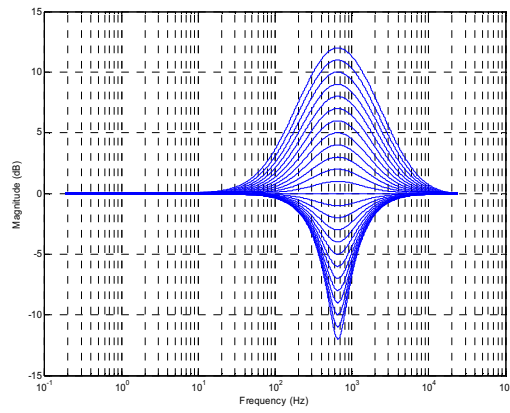
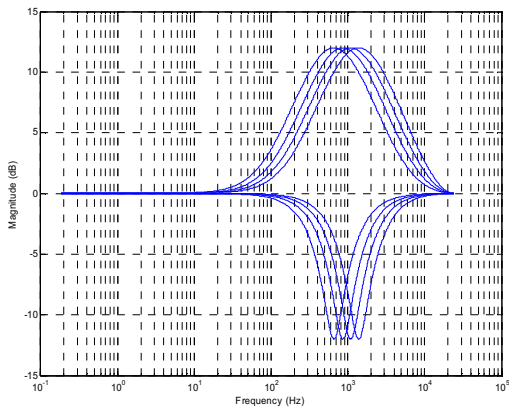

Figure 47 EQ Band 3 – Peak Filter Centre Frequencies, EQ3| Figure 48 EQ Band 3 – Peak Filter Gains for Lowest Cut-off Frequency, EQ3BW=0

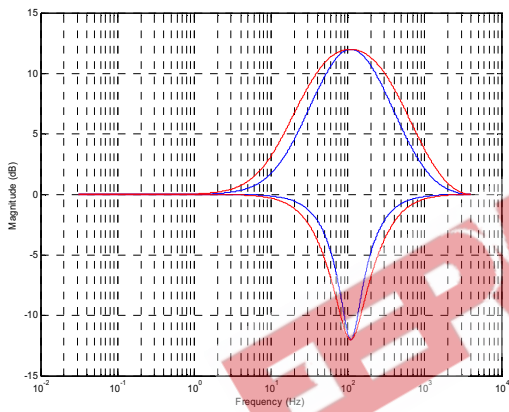

Figure 49 EQ Band 3 – EQ3BW=0, EQ3BW=1

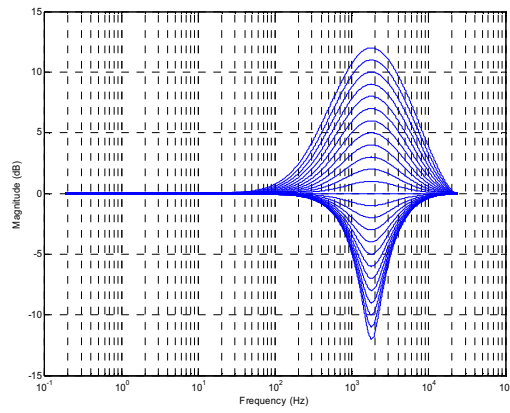
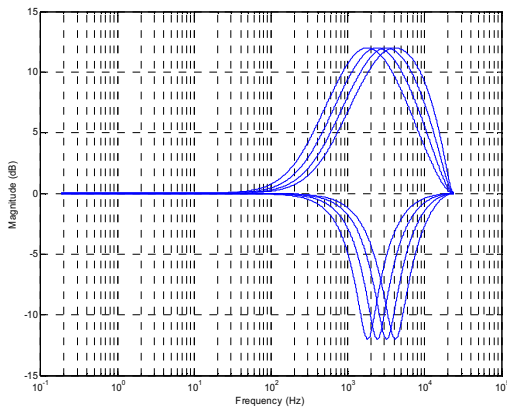

Figure 50 EQ Band 4 – Peak Filter Centre Frequencies, EQ3 | Figure 51 EQ Band 4 – Peak Filter Gains for Lowest Cut-off Frequency, EQ4BW=0

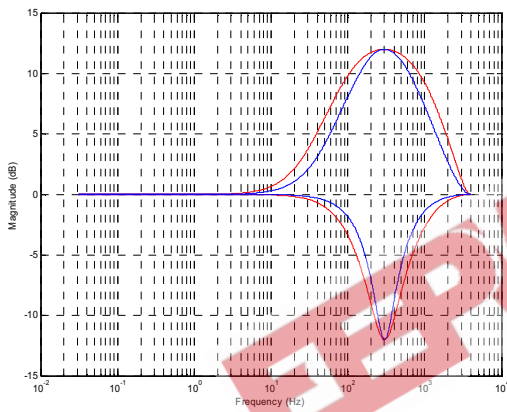

Figure 52 EQ Band 4 – EQ3BW=0, EQ3BW=1

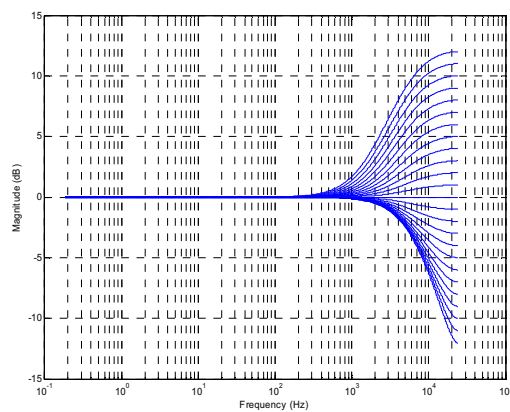
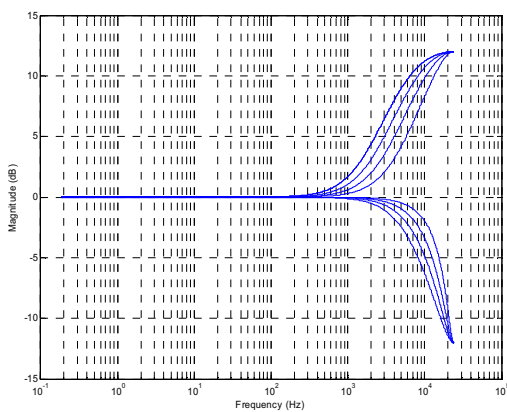

Figure 53 EQ Band 5 High Frequency Shelf Filter Cut-offs | Figure 54 EQ Band 5 Gains for Lowest Cut-off Frequency

Figure 55 shows the result of having the gain set on more than one channel simultaneously. The blue traces show each band (lowest cut-off/centre frequency) with $\pm 12\text{dB}$ gain. The red traces show the cumulative effect of all bands with $+12\text{dB}$ gain and all bands -12dB gain, with $\text{EqxBW}=0$ for the peak filters.

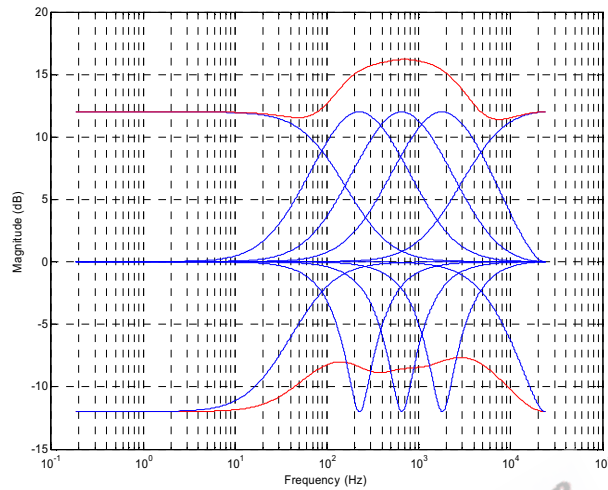

Figure 55 Cumulative Frequency Boost/Cut

EEPW.com.cn 电子产品世界

APPLICATION INFORMATION

RECOMMENDED EXTERNAL COMPONENTS

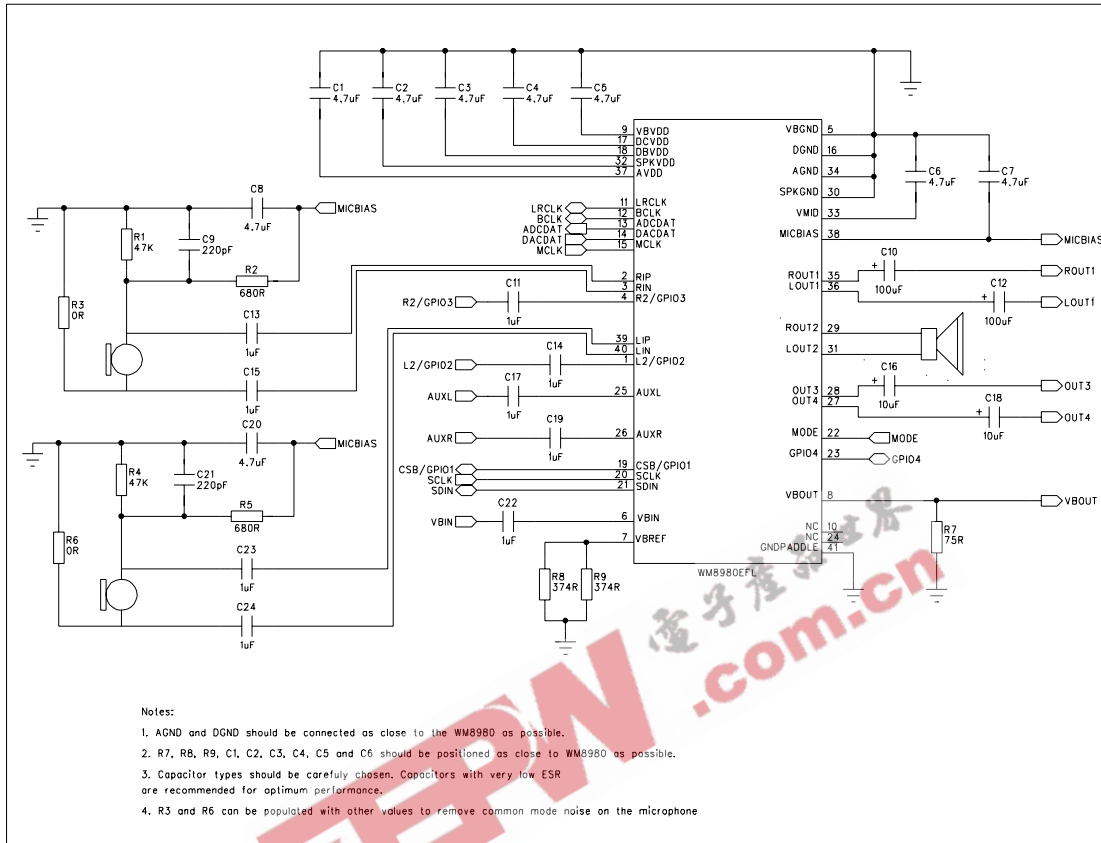
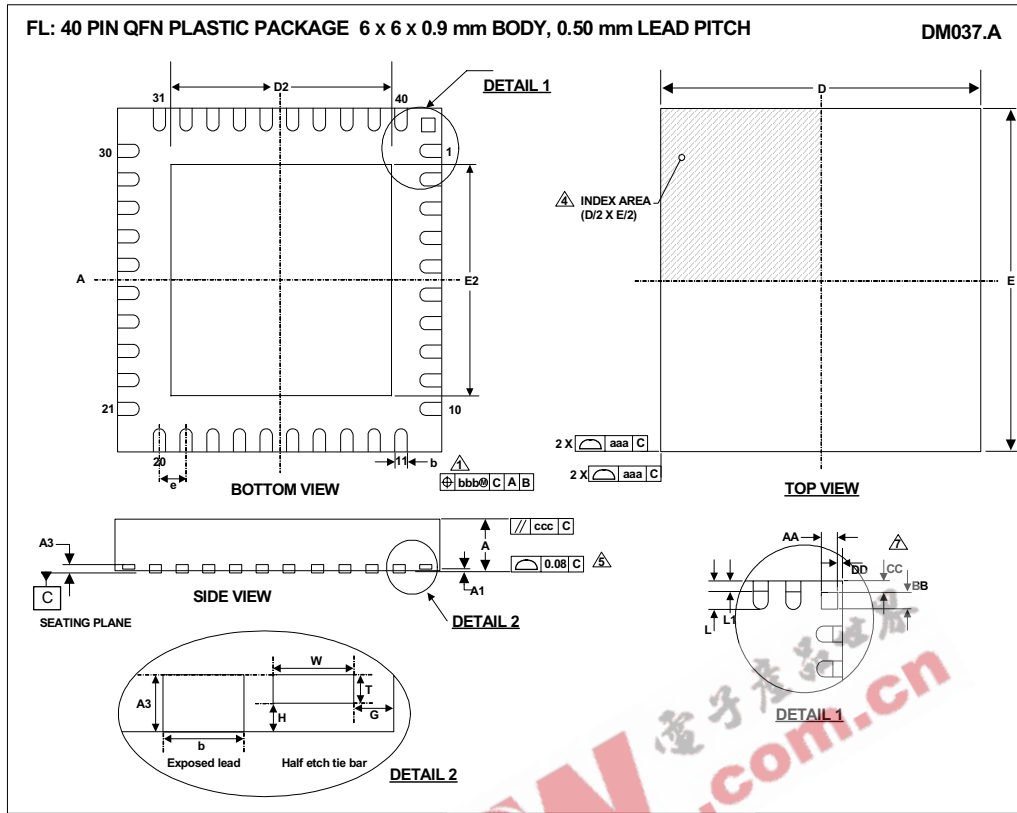

Figure 56 Recommended External Component Diagram

PACKAGE DIAGRAM



Symbols	Dimensions (mm)			
	MIN	NOM	MAX	NOTE
A	0.80	0.90	1.00	
A1	0	0.02	0.05	
A3		0.20 REF		
b	0.18	0.25	0.30	1
D		6.00 BSC		
D2	4.00	4.15	4.25	2
E		6.00 BSC		
E2	4.00	4.15	4.25	2
e		0.50 BSC		
G		0.213		
H		0.1		
L	0.30	0.40	0.50	
T		0.1		
W		0.2		
Tolerances of Form and Position				
aaa		0.15		
bbb		0.10		
ccc		0.10		
REF:	JEDEC, MO-220, VARIATION VJJD-2.			

Symbols	Dimensions (mm)			
	MIN	NOM	MAX	NOTE
AA	0.235			7
BB	0.235			7
CC	0.181			7
DD	0.181			7
L1	0.03		0.15	

- NOTES:
1. DIMENSION b APPLIES TO METALLIZED TERMINAL AND IS MEASURED BETWEEN 0.15 mm AND 0.30 mm FROM TERMINAL TIP.
 2. FALLS WITHIN JEDEC, MO-220, VARIATION VJJD-2.
 3. ALL DIMENSIONS ARE IN MILLIMETRES.
 4. THE TERMINAL #1 IDENTIFIER AND TERMINAL NUMBERING CONVENTION SHALL CONFORM TO JEDEC 95-1 SPP-002.
 5. COPLANARITY APPLIES TO THE EXPOSED HEAT SINK SLUG AS WELL AS THE TERMINALS.
 6. THIS DRAWING IS SUBJECT TO CHANGE WITHOUT NOTICE.
 7. DEPENDING ON THE METHOD OF LEAD TERMINATION AT THE EDGE OF THE PACKAGE, PULL BACK (L1) MAY BE PRESENT.

IMPORTANT NOTICE

Wolfson Microelectronics plc (WM) reserve the right to make changes to their products or to discontinue any product or service without notice, and advise customers to obtain the latest version of relevant information to verify, before placing orders, that information being relied on is current. All products are sold subject to the WM terms and conditions of sale supplied at the time of order acknowledgement, including those pertaining to warranty, patent infringement, and limitation of liability.

WM warrants performance of its products to the specifications applicable at the time of sale in accordance with WM's standard warranty. Testing and other quality control techniques are utilised to the extent WM deems necessary to support this warranty. Specific testing of all parameters of each device is not necessarily performed, except those mandated by government requirements.

In order to minimise risks associated with customer applications, adequate design and operating safeguards must be used by the customer to minimise inherent or procedural hazards. Wolfson products are not authorised for use as critical components in life support devices or systems without the express written approval of an officer of the company. Life support devices or systems are devices or systems that are intended for surgical implant into the body, or support or sustain life, and whose failure to perform when properly used in accordance with instructions for use provided, can be reasonably expected to result in a significant injury to the user. A critical component is any component of a life support device or system whose failure to perform can be reasonably expected to cause the failure of the life support device or system, or to affect its safety or effectiveness.

WM assumes no liability for applications assistance or customer product design. WM does not warrant or represent that any license, either express or implied, is granted under any patent right, copyright, mask work right, or other intellectual property right of WM covering or relating to any combination, machine, or process in which such products or services might be or are used. WM's publication of information regarding any third party's products or services does not constitute WM's approval, license, warranty or endorsement thereof.

Reproduction of information from the WM web site or datasheets is permissible only if reproduction is without alteration and is accompanied by all associated warranties, conditions, limitations and notices. Representation or reproduction of this information with alteration voids all warranties provided for an associated WM product or service, is an unfair and deceptive business practice, and WM is not responsible nor liable for any such use.

Resale of WM's products or services with statements different from or beyond the parameters stated by WM for that product or service voids all express and any implied warranties for the associated WM product or service, is an unfair and deceptive business practice, and WM is not responsible nor liable for any such use.

ADDRESS:

Wolfson Microelectronics plc
Westfield House
26 Westfield Road
Edinburgh
EH11 2QB
United Kingdom

Tel :: +44 (0)131 272 7000
Fax :: +44 (0)131 272 7001
Email :: sales@wolfsonmicro.com