

WIT2400

Frequency Hopping Transceiver OEM Module

Based on wireless expertise developed over the last 10 years, the WIT2400 is the ultimate OEM solution for wireless products. Operating in the unlicensed 2.4GHz ISM band, the WIT2400 combines extraordinary range with immunity to both jamming and multipath fading. With both FCC Part 15 and ETSI 300.328 compliance, the WIT2400 can be used anywhere in the world – license free. All in a small, simple to integrate package. And best of all, the WIT2400 has been FCC certified with a variety of antennas. This means your product will not have to undergo FCC type approval.

Reliable. The WIT2400 provides both reliable communication and reliable operation. With Frequency Hopping Spread Spectrum technology, the WIT2400 provides immunity to jamming as well as immunity to multipath fading. Utilizing Automatic Retransmit Request (ARQ) in combination with a 6KB buffer, transparent error-free communication is automatic. The WIT2400 has built-in data encryption adding a measure of security to the reliability.

Reliable operation is assured through our QA processes. All WIT2400s go through a full 48-hour burn-in. And compliance with ISO9002 is on schedule for completion by Q2 '99. With thousands of units in the field, the WIT2400 has a proven track record of reliability.

Flexible. The WIT2400 gives you the systems designer the flexibility to tailor the WIT2400 to your application. Practically all variables are under your software control. Even transmit power can be selected through software. Need guaranteed channel availability? No problem. Simply select TDMA mode rather than CSMA. You can also choose between synchronous and asynchronous communication. Standard communication rates between 1200 bps and 115.2 Kbps are software selectable as well as non-standard rates. The WIT2400 supports point-to-point and point-to-multipoint modes. And with multiple hopping patterns, co-locating systems is not a problem.

Simple. Simple to use and simple to integrate. Although the WIT2400 provides great flexibility, the default settings work for many applications. And those settings to be changed are modified through a straightforward command set.

The WIT2400 is simple to add to your product. Its small size and low power consumption reduce the

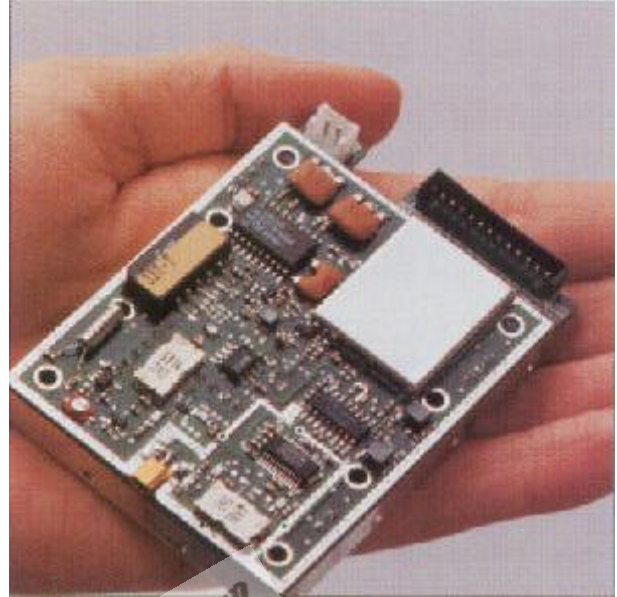

impact of the radio on your system design. And its CMOS signals make the electronic integration easy. Add the fact that your WIT2400-based product does not have to repeat the FCC type approval, and you have the solution to get your product to market much more easily, quickly and less costly than designing your own.

Let us be your experts. The WIT2400 lets you be an expert on your product and lets Digital Wireless be the expert on wireless transceivers. Put our 10 years experience with wireless technology to work for you.

Features:

- 2.4 GHz Frequency Hopping Spread Spectrum technology
- 115 Kbps data rate, full duplex
- 16 Hopping patterns
- Excellent range indoors and out
- Small size
- Low power
- FCC certified

Benefits:

- Worldwide license-free operation
- Immunity to jamming and multipath fading
- Supports co-location of multiple systems
- Cost effective solution for large coverage areas
- Easy integration into handheld and portable products
- Shortens time to market

To find out how to put Digital Wireless to work for you, visit our website www.digital-wireless.com or call:

770.564.5540



WIT2400 Specifications

GENERAL SPECIFICATIONS

RF Frequency	2400 to 2483 MHz		
Radio Certification	Certified under FCC Part 15.247 and ETS 300-328 rules, license free		
Operating Range	Indoor: 500' to 1000' Outdoor: 3500' with dipole antenna, >20 miles with gain antenna		
Network Topology	Star network		
Network Protocol	CSMA/CA or TDMA with ARQ		
Serial Data Interface	Asynchronous (RS-232) or synchronous		
I/O Data Rate	Up to 115.2 Kbps, software selectable		
Channel Data Rate	250 Kbps		
# of Frequency Channels	80		
RF Bandwidth	400 KHz		
Transmit Power Output	10 mW or 100 mW, software selectable		
Receiver Sensitivity	-95 dBm		
Supply voltage	5.5 v to 10 v, 6 v nominal		
Current Consumption (100mW Transmit Power, 115.2Kbps I/O)	Typical: Sleep – 1 mA Receive – 135 mA Transmit – 190 mA	Power Save: Sleep – 1mA Receive – 29mA Transmit – 185mA	
Size	61mm x 72mm x 16mm		
Weight	128g		
Operating Temperature	-20°C to 70°C		
Humidity	20% to 90% (non-condensing)		

CONNECTOR PINOUTS

Power Connector			
Pin	Signal	Description	
1	Gnd	Signal and Chassis Ground	
2	Vcc	Positive supply. Min 5.5 v, Nom 6.0 v, Max 10.0 v	
I/O Connector			
Pin	Signal	Type	Description
1	Gnd		Signal and chassis ground
2	TxD	Input	Transmit data
3	RxD	Output	Receive data
4	CFG	Input	Configuration selector. Used to switch radio between data and control mode
5	RTS	Input	Request to send. Used for receive flow control by the host
6	DTR	Input	Data terminal ready. Sleeps/wakes the radio transceiver
7	DCD	Output	Data carrier detect. For remotes, indicates successful synchronization
8	CTS	Output	Clear to send. Used for receive flow control by the radio
9	DSR	Output	Data set ready. Response to DTR. Indicates whether radio is asleep or awake.
10	TxC	Input	(Synchronous mode) Rising edge clocks data into the transceiver
11	RxC	Output	(Synchronous mode) Rising edge clocks data out of the transceiver
12	Res		Reserved for future use
13	Res		Reserved for future use

PHYSICAL SPECIFICATIONS

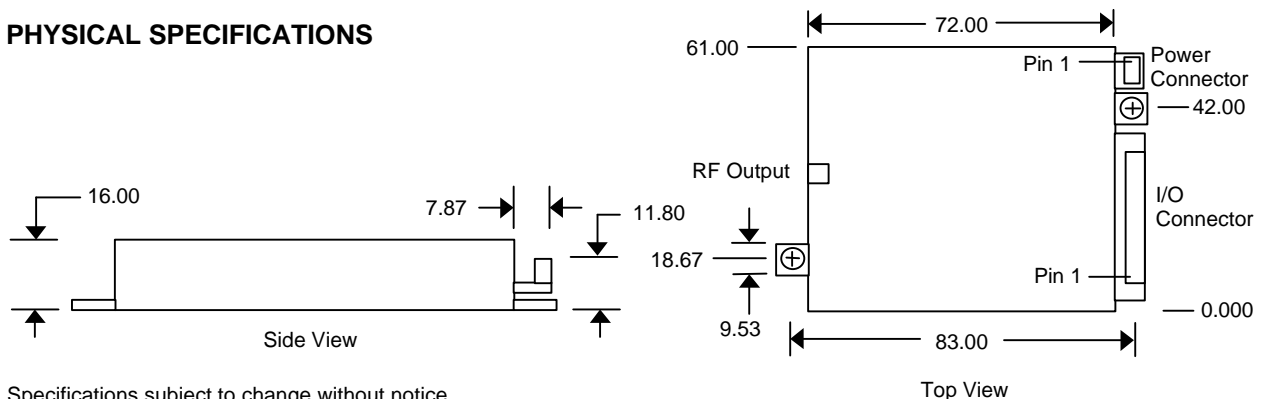

Specifications subject to change without notice.