



Product Brief

December 2006

Revision 1.0

WPCN385L LPC-to-LPC Switch, Fast Infrared Port, Serial Port and GPIOs

General Description

The WPCN385L, a member of the Winbond LPC SuperI/O family, is targeted for a wide range of portable applications. The WPCN385L is PC2001 and ACPI compliant, and features an LPC-to-LPC Switch with hot plugability, a Fast Infrared port (FIR, IrDA 1.1 compliant), Serial Port and General-Purpose Input/Output (GPIO) support for a total of 18 ports.

The WPCN385L enables glueless implementation of an LPC-to-LPC Switch between the motherboard LPC bus and the Docking Station, and supports hot insertion and hot removal.

Outstanding Features

- Pin and software compatible with the Winbond 87382
- LPC-to-LPC Switch with hot plugability, enables LPC devices in the Docking Station to be connected to the Main LPC Bus, thus reducing the number of signals required through the Docking Station connector
- Fast Infrared Port (FIR)
- Serial Port
- LPC bus interface, based on Intel's *LPC Interface Specification* Revision 1.1, August 2002 (supports CLKRUN and LPCPD signals)
- PC2001 and ACPI Revision 3.0 compliant
- 18 GPIO ports, including 11 with IRQ assertion capability
- Two testability modes (XOR Tree and TRI-STATE[®] device pins).
- 5V tolerant and back-drive protected pins (except LPC bus pins)
- 48-pin LQFP package

System Block Diagram

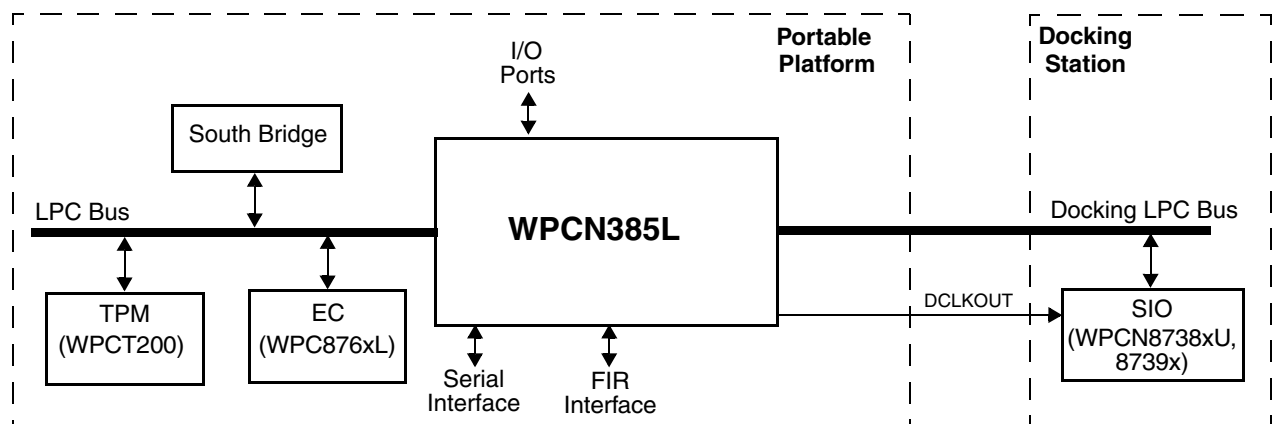

Features

- Docking LPC Switch
 - Hot plugability
 - $\overline{\text{LPCPD}}$ and $\overline{\text{CLKRUN}}$ support
 - The connection is controlled by software
 - Low switch resistance and propagation delay
 - Programmable Clock to Reset Delay
- Fast Infrared Port (FIR)
 - Software compatible with the 16550A and the 16450
 - Shadow register support for write-only bit monitoring
 - FIR IrDA 1.1 compliant
 - HP-SIR
 - ASK-IR option of SHARP-IR
 - DASK-IR option of SHARP-IR
 - Consumer Remote Control supports RC-5, RC-6, NEC, RCA and RECS 80
 - DMA support: one or two channels
- Serial Port (SP)
 - Software compatible with the 16550A and the 16450
 - Shadow register support for write-only bit monitoring
 - UART data rates up to 1.5 Mbaud
- 18 General-Purpose I/O (GPIO) Ports
 - Supports IRQ assertion
 - Programmable drive type for each output pin (open-drain, push-pull or output disable)
 - Programmable option for internal pull-up resistor on each input pin
 - Output lock option
 - Input debounce mechanism
- LPC System Interface
 - 8-bit I/O cycles
 - $\overline{\text{LPCPD}}$ and $\overline{\text{CLKRUN}}$ support
 - Implements PCI mobile design guide recommendation (*PCI Mobile Design Guide 1.1, Dec. 18, 1998*)
- PC2001 and ACPI 3.0 Compliant
 - PnP Configuration Register structure
 - Flexible resource allocation for all logical devices
 - Relocatable base address
 - 15 IRQ routing options
 - Optional 8-bit DMA channels (where applicable) selected from four possible DMA channels
- Clock Sources
 - 14.318 MHz or 48 MHz clock input
 - LPC clock, 0 or 30 MHz to 33 MHz
 - 14.318 MHz or 48 MHz clock output to the docking station
- Strap Configuration
 - Base Address (BADDR) strap to determine the base address of the Index-Data register pair
 - Docking LPC disable ($\overline{\text{DLPC_DIS}}$) strap to control the LPC-to-LPC Switch
 - Strap Inputs to select testability mode
- Power Supply
 - 3.3V supply operation
 - All pins are 5V tolerant, except LPC bus pins
 - All pins are back-drive protected, except LPC bus pins
- Testability
 - XOR Tree
 - TRI-STATE device pins

Internal Block Diagram

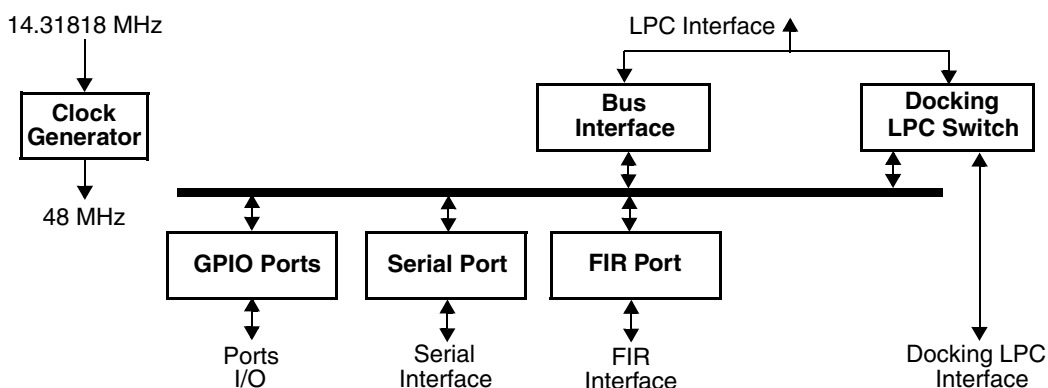

Physical Dimensions

All dimensions are in millimeters

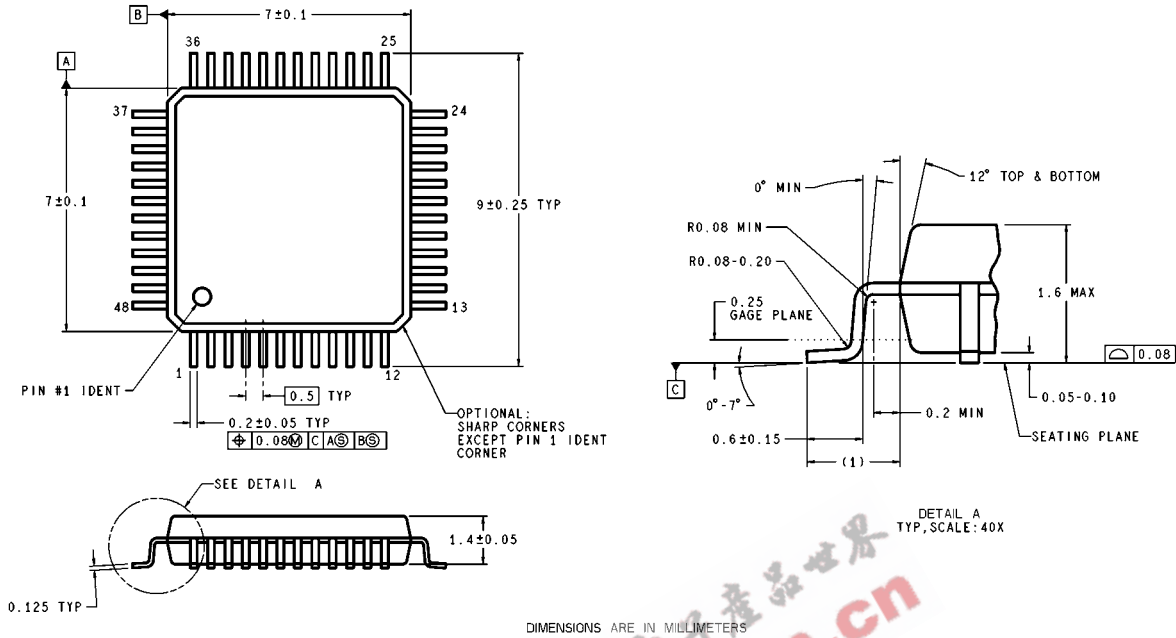

DIMENSIONS ARE IN MILLIMETERS

VBH48A (Rev D)

48-Pin Low-Profile Plastic Quad Flatpack (LQFP)
Order Number WPCN385L_0DG
 (Replace “_” with chip revision: A, B, and so on)

Important Notice

Winbond products are not designed, intended, authorized or warranted for use as components in systems or equipment intended for surgical implantation, atomic energy control instruments, airplane or spaceship instruments, transportation instruments, traffic signal instruments, combustion control instruments, or for other applications intended to support or sustain life. Furthermore, Winbond products are not intended for applications wherein failure of Winbond products could result or lead to a situation wherein personal injury, death or severe property or environmental damage could occur.

Winbond customers using or selling these products for use in such applications do so at their own risk and agree to fully indemnify Winbond for any damages resulting from such improper use or sales.

Headquarters
 No. 4, Creation Rd. III,
 Science-Based Industrial Park,
 Hsinchu, Taiwan
 TEL: 886-3-5770066
 FAX: 886-3-5665577
<http://www.winbond.com.tw/>

Winbond Electronics Corporation America
 2727 North First Street, San Jose,
 CA 95134, U.S.A.
 TEL: 1-408-9436666
 FAX: 1-408-5441798

Winbond Electronics (Shanghai) Ltd.
 27F, 2299 Yan An W. Rd. Shanghai,
 200336 China
 TEL: 86-21-62365999
 FAX: 86-21-62365998

Taipei Office
 9F, No.480, Rueiguang Rd.,
 Neihu District, Taipei, 114,
 Taiwan, R.O.C.
 TEL: 886-2-8177-7168
 FAX: 886-2-8751-3579

Winbond Electronics Corporation Japan
 7F Daini-ueno BLDG, 3-7-18
 Shinyokohama Kohoku-ku,
 Yokohama, 222-0033
 TEL: 81-45-4781881
 FAX: 81-45-4781800

Winbond Electronics (H.K.) Ltd.
 Unit 9-15, 22F, Millennium City,
 No. 378 Kwun Tong Rd.,
 Kowloon, Hong Kong
 TEL: 852-27513100
 FAX: 852-27552064

For Advanced PC Product Line information contact: APC.Support@winbond.com

Please note that all data and specifications are subject to change without notice.
 All the trademarks of products and companies mentioned in this product brief belong to their respective owners.