

## Narrow Band Radio Transceiver

WP-RF-RF650

### General

- Intelligent Modem RF Transceiver
- RF Data Rates to 100 kbps
- Upto 250metres Range
- Selectable 'Narrowband' RF Channels
- Crystal Controlled RF Design
- Supply Voltage 3.3V
- Serial Data Interface with Handshake
- Host Data Rates up to 38,400 Baud
- Very Stable Operating Frequency
- Low Profile Ceramic DIL Package
- Operates from -20 to +70 0C

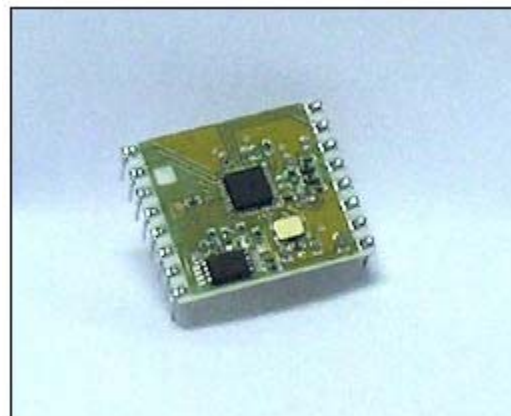

### Operating Modes

- Point to Point
- broadcast
- One to Many Network
- Many to One Network

### Applications

- Wireless Security Systems
- EPOS Terminals
- Sensor Data logging
- Remote Telemetry & Telecommand
- Remote Meter Reading

### Description

The RF650 radio transceiver module provides a reliable wireless communications for the transfer of data at Gaussian Frequency Shift Keying (GFSK), Manchester encoded, RF data rates of up to 100 kbps. Their unique features of narrow band operation and user channel selection combined with excellent interference rejection make them an ideal choice for next generation applications. The transceivers have the functions of a complete radio modem and simply require CMOS/TTL data at the transmit input and the corresponding transceiver(s) output the same data. Preamble and CRC are automatically generated and added to the RF transmission.

Operating within the 433MHz band the modules operate in user selectable channels. The RF650 can use any channel in 100kHz steps. The modules both use a crystal controlled design which provides narrow band performance which is far superior to other wideband 'SAW' based designs.

Possible applications include one-to-one and multi-node wireless links in applications including car and building security, EPOS, inventory tracking, remote industrial process monitoring and computer networking.

Because of their small size and low power requirements, both modules are ideal for use in portable, battery powered applications such as hand-held terminals.

### Part Numbering

WP-RF-RF650	Tranceiver IC PDIP Package - 16pin DIP
WP-RF-RF650-EV	Evaluation Kit for Smart Radio - TBD

Pinout Detail

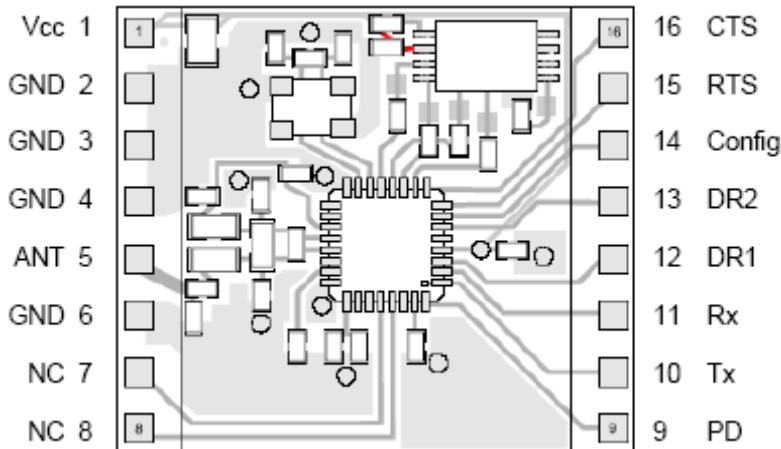

Pin Descriptions

Pin Number	Name	Type	Description
1	Vcc	Power	Positive supply voltage connection. Decouple with 100n ceramic capacitor to ground.
2, 3, 4, 6	GND	Power	Connect to 0 volts.
5	Antenna	In / Out	Nominal 50 ohm input/output impedance capacitively isolated from the internal circuit.
7, 8	nc	-	No Connection.
9	PD	In	Power Down pin. Take low for low power standby mode.
10	Tx	In	Transmit data input from host controller. Data input to the transmitter can be directly interfaced to CMOS logic drive operating on the same supply voltage as the transceiver.
11	Rx	Out	Received data output to host controller (CMOS logic out) representing true data as supplied to the transmitter.
12, 13	Data Rate	In	Host Data Rate selection.
14	Configuration	In	High for normal operation, low to configure module.
15	RTS	In	Logic '0' is Request To Send. Take low when the host is ready to send data to the module or is ready to receive data from the module.
16	CTS	Out	Logic '0' is Clear To Send. Taken high when the module is busy.

Host Data Rate Selection

DR2 (pin 13)	DR1 (pin12)	Baud Rate
0	0	4,800
0	1	9,600
1	0	19,200
1	1	38,400



## Applications

The RF650 RF module has applications in many areas where reliable half duplex communications are required over ranges up to 200 metres. The crystal controlled narrow band design gives reliable performance within the 433MHz band.

The addressing protocol employed enables many different configurations such including; one-to-one operation; for point to point data communication broadcast operation; where a single master address many RF650 modules concurrently. (using many RF650 modules set to the same address), one-to-many; A network consisting a master and many slaves (the receivers all have the same address) many-to-one; where the transmitters all send to a single receiver address.

Because each RF650 can contain a unique address, multiple RF650 networks can co-exist in the same area.

## Operation

The Host Data Rate pins are read when the PD pin goes high. The RF650 must be put into standby mode by taking the PD pin low in order to change the selection.

The size of RF data packets are set during configuration. If fewer bytes are received by the RF650 than the preset size, then after 10ms from the last byte received from the host, the RF packet will be processed (expanded to meet the preset packet size) and transmitted. The RF data packet size must be set the same for transmitter and receiver, otherwise the received packets will be discarded.

In order to optimise data rate , in a point-to-point configuration where data is mostly being sent in one direction, the packet size for one data direction can be set to the maximum size, however the reverse direction may be set to a smaller packet size, to implement an acknowledge reply for example.

The RTS pin overrides the timeout value. If a short data packet is sent, RF transmission will start as soon as the RTS pin is taken 'high' after the last byte is sent to the module.

The RF650 contains an on-board data buffer equal to two data packets. Therefore if RTS is asserted (then the host is unable to receive data) the RF650 will store a max of two data bytes, all further datapackets received will be discarded.

No RF packets will be received by the module when it is in power down standby mode. Each RF650 has its own preset address. This is set during configuration. Any data received is examined and the address header embedded within the data packet is compared with the RF60 address. Only data received with matching address will be processed and output to the host, all other data will be discarded.

All RF650 modules are shipped with a default address of 7E7E7E7E.

## RF650 Configuration

The configuration of the RF650 module may be changed by setting the Configuration pin low and sending a set of configuration data bytes to the module on the Tx pin.

Byte	Name	Description	Default Supplied Value
0	Destination Address	MSB	7E hex
1			7E hex
2			7E hex
3		LSB	7E hex
4	RF650 Address	MSB	7E hex
5			7E hex
6			7E hex
7		LSB	7E hex
8	RF Channel	100 kHz step offset from 422.4MHz	107 (433.1MHz)
9	Tx Power	0 = -10dBm	0 (-10dBm)
		1 = -2dBm	
		2 = +6dBm	
		3 = +10dBm	
10	Tx data packet size	1 – 31 bytes	30 bytes
11	Rx data packet size	1 – 31 bytes	30 bytes

The RF Channel is calculated as:

Configuration value = (desired RF frequency – 422.4MHz) \* 10

The Configuration pin must be held low for at least the first byte to change the RF650 module into configuration mode. If the Configuration pin is still low at the end of the configuration then the module will send the current configuration back to the host. To retrieve the current configuration without changing any options the host can send a single byte to the module and wait for the response.

It is not necessary to send all configuration bytes to the module, but all data sent must be valid. For example to change the destination address the host may just send four bytes. Configuration data excluded from the end of the data stream will be unchanged. The RF650 module will accept a short configuration after a 10ms timeout after the last byte sent to the module, or when the RTS pin goes high. This allows for the host to easily change the destination address of the RF data packet, thus enabling one RF650 to send individual data to several different recipient modules.

A destination address of 00000000 will reset the RF650 to the default settings shown above. RF data packets received by the RF650 with the embedded destination address which matches the RF650 address will be accepted, processed and passed to the host, all of the RF data packets will be ignored.

When configuring the destination or RF650 address an incorrect number of bytes for an address will leave the current address unchanged.

An invalid Transmitter Power or Packet Size setting will leave the current setting unchanged.

**Application information**

Connection of the RF650 to an RS232 host terminal device such as a PC serial port may easily be achieved using the circuit as below.

The 9 way 'D' socket (J1) provides the standard pinout required to connect directly to the serial port of any std PC using a 9 way male/female cable. The MAX3232 (U2, a low voltage RS232 line driver) provides level conversion between the RS232 levels on the serial port and the logic levels pins of the RF650 module. (note that direct connection of RS232 levels to the module will result in immediate destruction of the device). J6 provides power to the circuit, pin 2 of J6 connects to your Vcc supply while pin 1 connects to your Ground.

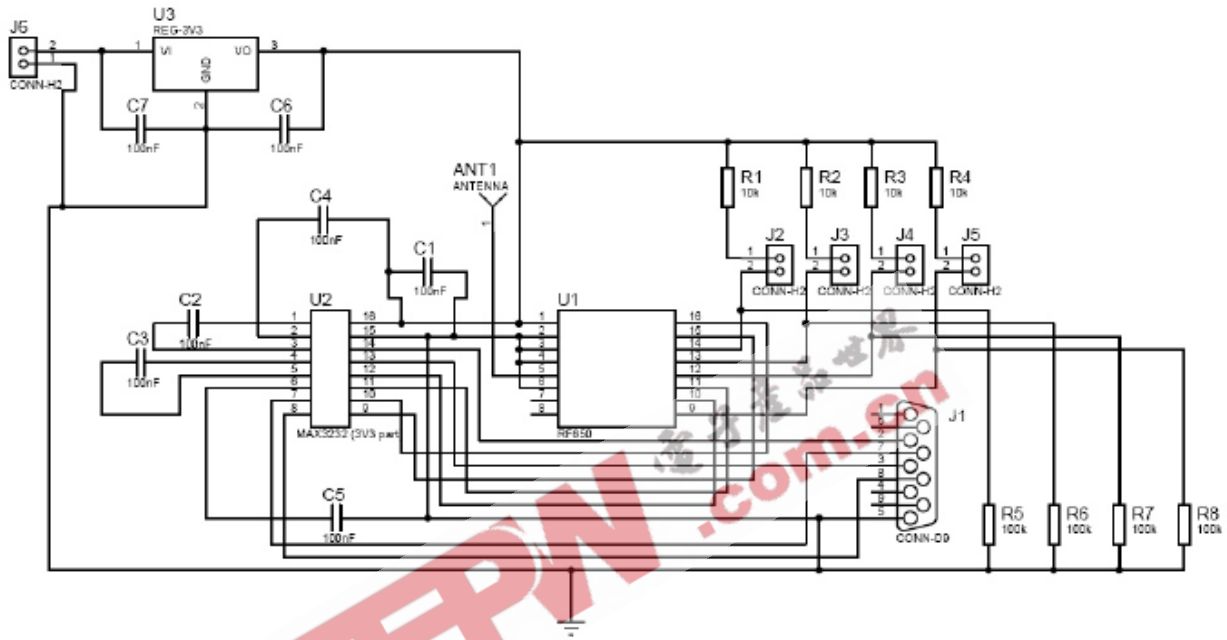

Circuit notes:

J2,3,4 and 5 allow the selection of the following modes:

- J2 when shorted sets the module for normal running mode or if left open selects configuration mode.
- J3 and J4 selects the host data rate.
- J5 when sorted puts the module into standby mode or when left open in normal operation.

If two such circuits are constructed then it will be possible to interconnect two PC's and test out the performance of the hybrids. When both circuits are powered up it will be necessary for them to have each others address in the "Destination Address" register.

## Antenna Design

The design and positioning of the aerial is as crucial as the module performance itself in achieving a good wireless system range. The following will assist the designer in maximising system performance.

The RF ground pin should be connected to a ground plane which should shield the aerial connection and the PCB layout around the aerial track itself should be such as to give a 50 Ohm impedance. The aerial should be kept as far away from sources of electrical interference as physically possible. The specified power supply decoupling capacitors should be placed close to the module as possible and have direct connections to the relevant pins.

The antenna 'hot end' should be kept clear of any objects, especially any metal as this can severely restrict the efficiency of the antenna to receive power. Earth planes restricting the radiation path of the antenna will also have the same effect.

The best range will be achieved with either a straight piece of wire, rod or PCB track @  $\frac{1}{4}$  wavelength (15.5cm @ 433.9MHz). Increased range may be achieved if this  $\frac{1}{4}$  wave antenna is placed perpendicular to and in the middle of a solid earth plane measuring at least 16cm radius. In this case, the antenna should be connected to the module using 50 Ohm coaxial cable and the PCB track layout tips given above should be observed.

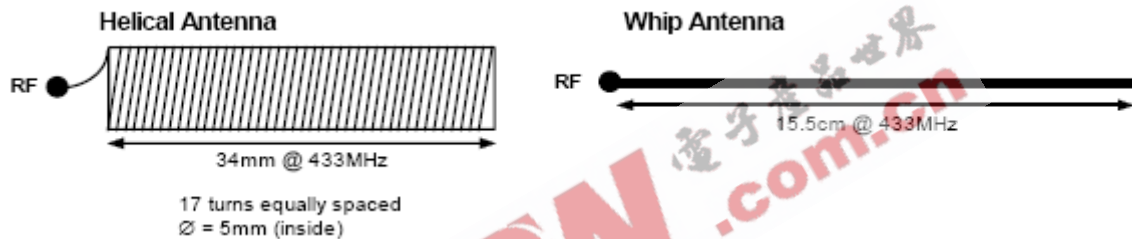

## Technical Specifications

### Absolute Maximum Ratings

Operating temperature:	-20 0 C to +80 0 C
Storage temperature:	-40 0 C to +100 0 C
Supply Voltage:	-0.3 to 3.6V
Data input:	-0.3 to Vcc+0.3v

### Electrical Characteristics

	Min.	Typ.	Max.	Units	Notes
<b>DC Levels</b>					
Supply voltage	1.9	3.3	3.6	V	1
Supply current (Transmit mode)	11		30	mA	
Supply current (Receive mode)		12.5		mA	
Supply current (Standby mode)		125		uA	
Data input/output high	Vcc-0.3		Vcc	V	
Data input/output low	0		0.3	V	
<b>RF</b>					
Working frequency	430.0	433.1	440.0	MHz	2
Receiver sensitivity		-100		dBm	
Transmitter RF power out		+10		dBm	
Frequency deviation		+/-50		kHz	
GFSK manchester encoded data rate		100		kbps	
Operating temperature	-20		+70	Deg C	
<b>Dynamic Timing</b>					
Power up to stable receiver data out		30		mS	
Power up to full RF out		30		mS	
Standby to Receive mode		1		mS	
Standby to Transmit mode		1		mS	

### Notes

1. Supply voltage should have <10mV ripple.
2. The application operating frequency must be chosen to comply with the Short Range device regulation in the area of operation.

Mechanical Detail

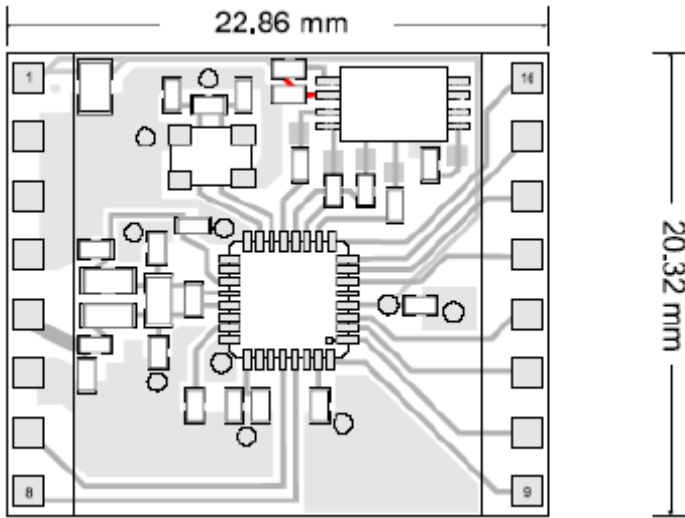

Dimensions: mm

