

## CPU Supervisor with 8Kbit SPI EEPROM

This device combines four popular functions, Power-on Reset Control, Watchdog Timer, Supply Voltage Supervision, and Block Lock Serial EEPROM Memory in one package. This combination lowers system cost, reduces board space requirements, and increases reliability.

Applying power to the device activates the power-on reset circuit which holds RESET active for a period of time. This allows the power supply and oscillator to stabilize before the processor can execute code.

The Watchdog Timer provides an independent protection mechanism for microcontrollers. When the microcontroller fails to restart a timer within a selectable time out interval, the device activates the RESET signal. The user selects the interval from three preset values. Once selected, the interval does not change, even after cycling the power.

The device's low V<sub>CC</sub> detection circuitry protects the user's system from low voltage conditions, resetting the system when V<sub>CC</sub> falls below the minimum V<sub>CC</sub> trip point. RESET is asserted until V<sub>CC</sub> returns to the proper operating level and stabilizes. Five industry standard V<sub>TRIP</sub> thresholds are available, however, Intersil's unique circuits allow the threshold to be reprogrammed to meet custom requirements or to fine-tune the threshold for applications requiring higher precision.

## Pinouts

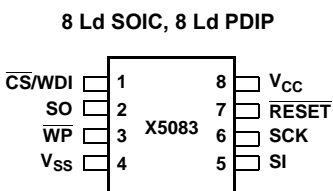
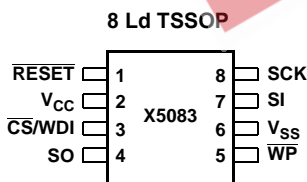

## Features

- Low V<sub>CC</sub> detection and reset assertion
  - Four standard reset threshold voltages 4.63V, 4.38V, 2.93V, 2.63V
  - Re-program low V<sub>CC</sub> reset threshold voltage using special programming sequence
  - Reset signal valid to V<sub>CC</sub> = 1V
- Selectable time out watchdog timer
- Long battery life with low power consumption
  - <50µA max standby current, watchdog on
  - <1µA max standby current, watchdog off
  - <400µA max active current during read
- 8Kbits of EEPROM
- Save critical data with Block Lock™ memory
  - Block lock first or last page, any 1/4 or lower 1/2 of EEPROM array
- Built-in inadvertent write protection
  - Write enable latch
  - Write protect pin
- SPI Interface - 3.3MHz clock rate
- Minimize programming time
  - 16 byte page write mode
  - 5ms write cycle time (typical)
- SPI modes (0,0 & 1,1)
- Available packages
  - 8 Ld TSSOP, 8 Ld SOIC, 8 Ld PDIP
- Pb-free plus anneal available (RoHS compliant)

## Applications

- Communications Equipment
  - Routers, Hubs, Switches
  - Set Top Boxes
- Industrial Systems
  - Process Control
  - Intelligent Instrumentation
- Computer Systems
  - Desktop Computers
  - Network Servers
- Battery Powered Equipment

Typical Application

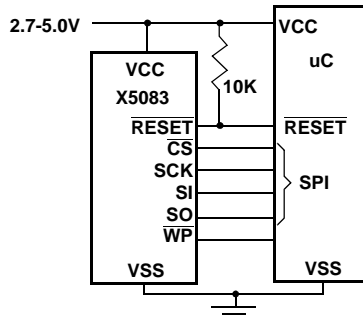

Block Diagram

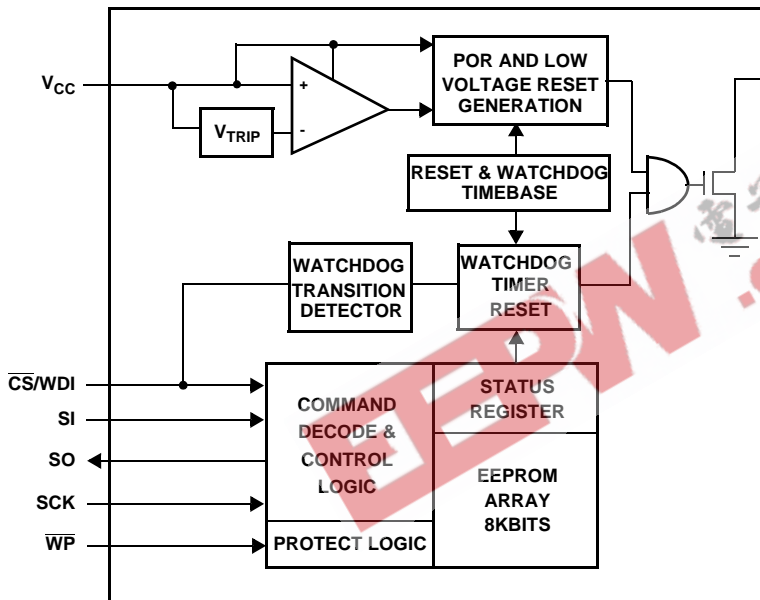

STANDARD $V_{TRIP}$ LEVEL	SUFFIX
4.63V (+/-2.5%)	-4.5A
4.38V (+/-2.5%)	-4.5
2.93V (+/-2.5%)	-2.7A
2.63V (+/-2.5%)	-2.7

See "Ordering Information" on page 3 for more details  
For Custom Settings, call Intersil.

## X5083

### Ordering Information

PART NUMBER $\overline{\text{RESET}}$ (ACTIVE LOW)	PART MARKING	V <sub>CC</sub> RANGE (V)	V <sub>TRIP</sub> RANGE	TEMPERATURE RANGE (°C)	PACKAGE		
X5083P-4.5A	X5083P AL	4.5-5.5	4.5-4.75	0 to 70	8 Ld PDIP		
X5083PI-4.5A	X5083P AM			-40 to 85	8 Ld PDIP		
X5083S8-4.5A	X5083 AL			0 to 70	8 Ld SOIC		
X5083S8Z-4.5A (Note)	X5083 Z AL			0 to 70	8 Ld SOIC (Pb-free)		
X5083S8I-4.5A*	X5083 AM			-40 to 85	8 Ld SOIC		
X5083S8IZ-4.5A* (Note)	X5083 Z AM			-40 to 85	8 Ld SOIC (Pb-free)		
X5083V8-4.5A	583AL			0 to 70	8 Ld TSSOP		
X5083V8I-4.5A	583AM			-40 to 85	8 Ld TSSOP		
X5083P	X5083P	4.5-5.5	4.25-4.5	0 to 70	8 Ld PDIP		
X5083PI	X5083P I			-40 to 85	8 Ld PDIP		
X5083SI	X5083 I			-40 to 85	8 Ld SOIC		
X5083S8	X5083			0 to 70	8 Ld SOIC		
X5083S8Z (Note)	X5083 Z			0 to 70	8 Ld SOIC (Pb-free)		
X5083S8I*	X5083 I			-40 to 85	8 Ld SOIC		
X5083S8IZ* (Note)	X5083 Z I			-40 to 85	8 Ld SOIC (Pb-free)		
X5083V8	X583			0 to 70	8 Ld TSSOP		
X5083V8I	583I			-40 to 85	8 Ld TSSOP		
X5083P-2.7A	X5083P AN			2.7-5.5	2.85-3.0	0 to 70	8 Ld PDIP
X5083PI-2.7A	X5083P AP					-40 to 85	8 Ld PDIP
X5083S8-2.7A	X5083 AN					0 to 70	8 Ld SOIC
X5083S8Z-2.7A (Note)	X5083 Z AN	0 to 70	8 Ld SOIC (Pb-free)				
X5083S8I-2.7A	X5083 AP	-40 to 85	8 Ld SOIC				
X5083S8IZ-2.7A (Note)	X5083 Z AP	-40 to 85	8 Ld SOIC (Pb-free)				
X5083V8-2.7A	583AN	0 to 70	8 Ld TSSOP				
X5083V8I-2.7A	583AP	-40 to 85	8 Ld TSSOP				
X5083P-2.7	X5083P F	2.7-5.5	2.55-2.7	0 to 70	8 Ld PDIP		
X5083PI-2.7	X5083P G			-40 to 85	8 Ld PDIP		
X5083S8-2.7*	X5083 F			0 to 70	8 Ld SOIC		
X5083S8Z-2.7* (Note)	X5083 Z F			0 to 70	8 Ld SOIC (Pb-free)		
X5083S8I-2.7*	X5083 G			-40 to 85	8 Ld SOIC		
X5083S8IZ-2.7* (Note)	X5083 Z G			-40 to 85	8 Ld SOIC (Pb-free)		
X5083V8-2.7	583F			0 to 70	8 Ld TSSOP		
X5083V8I-2.7	583G			-40 to 85	8 Ld TSSOP		
X5083V8IZ-2.7 (Note)				-40 to 85	8 Ld TSSOP (Pb-free)		

NOTE: Intersil Pb-free plus anneal products employ special Pb-free material sets; molding compounds/die attach materials and 100% matte tin plate termination finish, which are RoHS compliant and compatible with both SnPb and Pb-free soldering operations. Intersil Pb-free products are MSL classified at Pb-free peak reflow temperatures that meet or exceed the Pb-free requirements of IPC/JEDEC J STD-020.

\*Add "-T1" suffix for tape and reel.

## Pin Description

PIN (SOIC/ PDIP)	PIN TSSOP	NAME	FUNCTION
1	3	$\overline{\text{CS}}/\overline{\text{WDI}}$	<b>Chip Select Input.</b> $\overline{\text{CS}}$ HIGH, deselects the device and the SO output pin is at a high impedance state. Unless a nonvolatile write cycle is underway, the device will be in the standby power mode. $\overline{\text{CS}}$ LOW enables the device, placing it in the active power mode. Prior to the start of any operation after power-up, a HIGH to LOW transition on $\overline{\text{CS}}$ is required. <b>Watchdog Input.</b> A HIGH to LOW transition on the WDI pin restarts the Watchdog timer. The absence of a HIGH to LOW transition within the watchdog time out period results in RESET going active.
2	4	SO	<b>Serial Output.</b> SO is a push/pull serial data output pin. A read cycle shifts data out on this pin. The falling edge of the serial clock (SCK) clocks the data out.
5	7	SI	<b>Serial Input.</b> SI is a serial data input pin. Input all opcodes, byte addresses, and memory data on this pin. The rising edge of the serial clock (SCK) latches the input data. Send all opcodes (Table 1), addresses and data MSB first.
6	8	SCK	<b>Serial Clock.</b> The Serial Clock controls the serial bus timing for data input and output. The rising edge of SCK latches in the opcode, address, or data bits present on the SI pin. The falling edge of SCK changes the data output on the SO pin.
3	5	$\overline{\text{WP}}$	<b>Write Protect.</b> When $\overline{\text{WP}}$ is LOW, nonvolatile write operations to the memory are prohibited. This "Locks" the memory to protect it against inadvertent changes when WP is HIGH, the device operates normally.
4	6	$V_{\text{SS}}$	Ground
8	2	$V_{\text{CC}}$	Supply Voltage
7	1	$\overline{\text{RESET}}$	<b>Reset Output.</b> $\overline{\text{RESET}}$ is an active LOW, open drain output which goes active whenever $V_{\text{CC}}$ falls below the minimum $V_{\text{CC}}$ sense level. It will remain active until $V_{\text{CC}}$ rises above the minimum $V_{\text{CC}}$ sense level for 250ms. $\overline{\text{RESET}}$ goes active if the watchdog timer is enabled and CS remains either HIGH or LOW longer than the selectable watchdog time out period. A falling edge of CS will reset the watchdog timer. RESET goes active on power-up at about 1V and remains active for 250ms after the power supply stabilizes.

## Principles of Operation

### Power-on Reset

Application of power to the X5083 activates a power-on reset circuit. This circuit goes LOW at 1V and pulls the  $\overline{\text{RESET}}$  pin active. This signal prevents the system microprocessor from starting to operate with insufficient voltage or prior to stabilization of the oscillator.  $\overline{\text{RESET}}$  active also blocks communication to the device through the SPI interface. When  $V_{\text{CC}}$  exceeds the device  $V_{\text{TRIP}}$  value for 200ms (nominal) the circuit releases  $\overline{\text{RESET}}$ , allowing the processor to begin executing code. While  $V_{\text{CC}} < V_{\text{TRIP}}$  communications to the device are inhibited.

### Low Voltage Monitoring

During operation, the X5083 monitors the  $V_{\text{CC}}$  level and asserts  $\overline{\text{RESET}}$  if supply voltage falls below a preset minimum  $V_{\text{TRIP}}$ . The  $\overline{\text{RESET}}$  signal prevents the microprocessor from operating in a power fail or brownout condition and terminates any SPI communication in progress. The  $\overline{\text{RESET}}$  signal remains active until the voltage drops below 1V. It also remains active until  $V_{\text{CC}}$  returns and exceeds  $V_{\text{TRIP}}$  for 200ms.

When  $V_{\text{CC}}$  falls below  $V_{\text{TRIP}}$ , any communications in progress are terminated and communications are inhibited until  $V_{\text{CC}}$  exceeds  $V_{\text{TRIP}}$  for  $t_{\text{PURST}}$ .

### Watchdog Timer

The watchdog timer circuit monitors the microprocessor activity by monitoring the WDI input. The microprocessor must toggle the  $\overline{\text{CS}}/\overline{\text{WDI}}$  pin periodically to prevent a RESET signal. The  $\overline{\text{CS}}/\overline{\text{WDI}}$  pin must be toggled from HIGH to LOW prior to the expiration of the watchdog time out period. The state of two nonvolatile control bits in the status register determine the watchdog timer period. The microprocessor can change these watchdog bits with no action taken by the microprocessor these bits remain unchanged, even after total power failure.

### $V_{\text{CC}}$ Threshold Reset Procedure

The X5083 is shipped with a standard  $V_{\text{CC}}$  threshold ( $V_{\text{TRIP}}$ ) voltage. This value will not change over normal operating and storage conditions. However, in applications where the standard  $V_{\text{TRIP}}$  is not exactly right, or if higher precision is needed in the  $V_{\text{TRIP}}$  value, the X5083 threshold may be adjusted. The procedure is described below, and uses the application of a high voltage control signal.

### Setting the $V_{\text{TRIP}}$ Voltage

This procedure is used to set the  $V_{\text{TRIP}}$  to a higher voltage value. For example, if the current  $V_{\text{TRIP}}$  is 4.4V and the new  $V_{\text{TRIP}}$  is 4.6V, this procedure will directly make the change. If the new setting is to be lower than the current setting, then it is necessary to reset the trip point before setting the new value.

To set the new  $V_{TRIP}$  voltage, apply the desired  $V_{TRIP}$  threshold voltage to the  $V_{CC}$  pin and tie the  $\overline{WP}$  pin to the programming voltage  $V_P$ . Then send a WREN command, followed by a write of Data 00h to address 01h.  $\overline{CS}$  going HIGH on the write operation initiates the  $V_{TRIP}$  programming sequence. Bring  $\overline{WP}$  LOW to complete the operation.

**Note:** This operation also writes 00h to array address 01h.

**Resetting the  $V_{TRIP}$  Voltage**

This procedure is used to set the  $V_{TRIP}$  to a “native” voltage level. For example, if the current  $V_{TRIP}$  is 4.4V and the new  $V_{TRIP}$  must be 4.0V, then the  $V_{TRIP}$  must be reset. When  $V_{TRIP}$  is reset, the new  $V_{TRIP}$  is something less than 1.7V.

This procedure must be used to set the voltage to a lower value.

To reset the new  $V_{TRIP}$  voltage, apply the desired  $V_{TRIP}$  threshold voltage to the  $V_{CC}$  pin and tie the  $\overline{WP}$  pin to the programming voltage  $V_P$ . Then send a WREN command, followed by a write of data 00h to address 03h.  $\overline{CS}$  going HIGH on the write operation initiates the  $V_{TRIP}$  programming sequence. Bring  $\overline{WP}$  LOW to complete the operation.

**Note:** This operation also writes 00h to array address 03h.

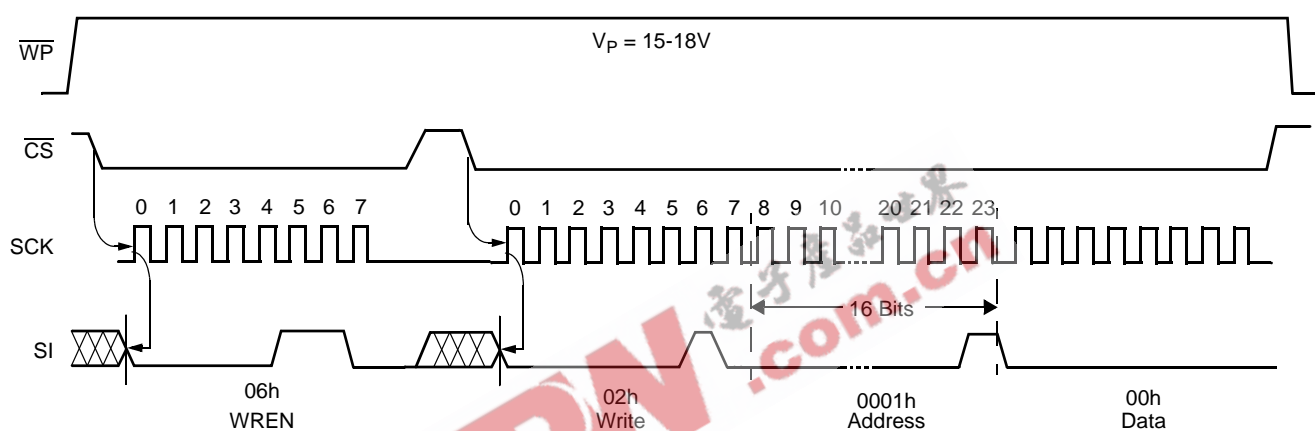

FIGURE 1. SET  $V_{TRIP}$  LEVEL SEQUENCE ( $V_{CC}$  = DESIRED  $V_{TRIP}$  VALUE)

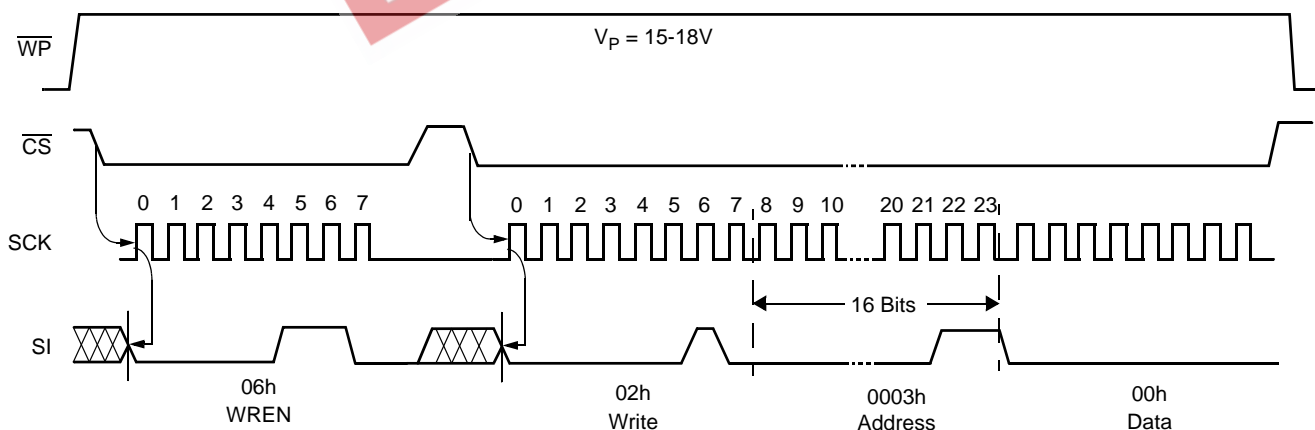

FIGURE 2. RESET  $V_{TRIP}$  LEVEL SEQUENCE ( $V_{CC}$  > 3V.  $\overline{WP}$  = 15-18V)

# X5083

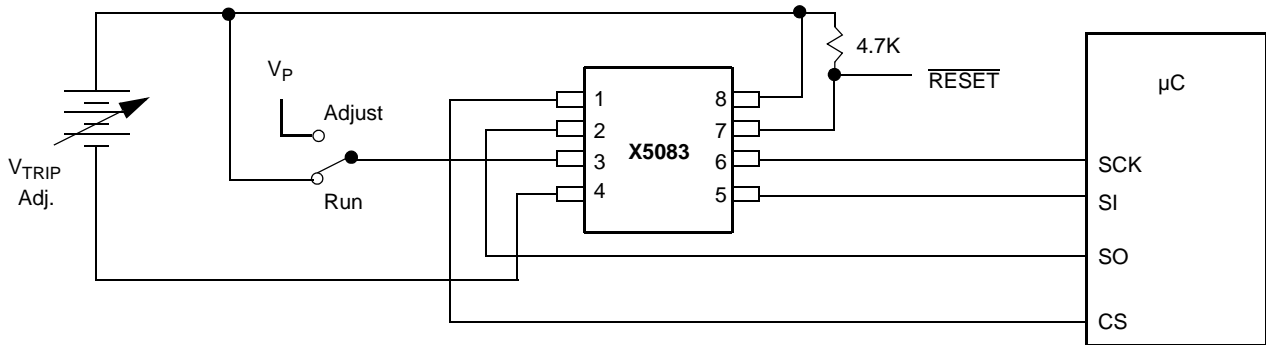

FIGURE 3. SAMPLE  $V_{TRIP}$  RESET CIRCUIT

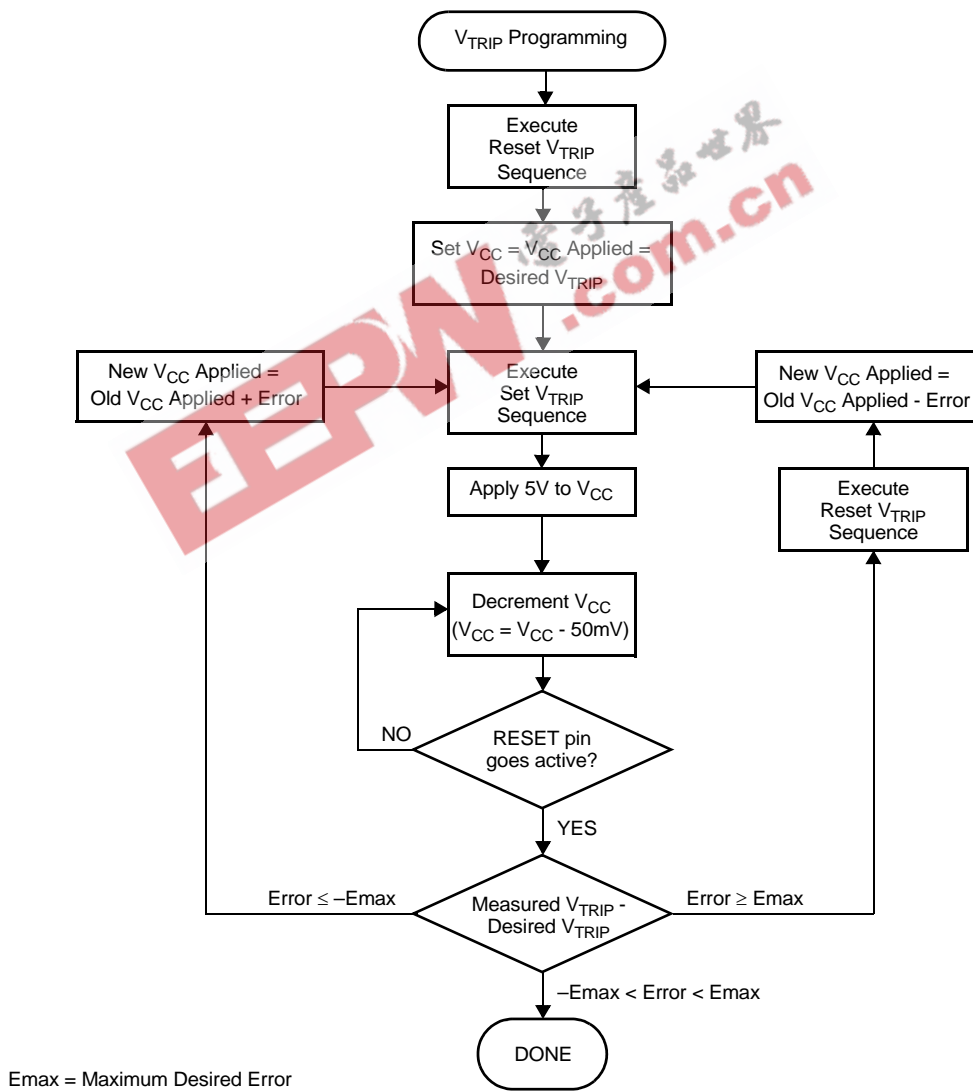

FIGURE 4.  $V_{TRIP}$  PROGRAMMING SEQUENCE

### SPI Serial Memory

The memory portion of the device is a CMOS serial EEPROM array with Intersil's block lock protection. The array is internally organized as x 8. The device features a Serial Peripheral Interface (SPI) and software protocol allowing operation on a simple four-wire bus.

The device utilizes Intersil's proprietary Direct Write™ cell, providing a minimum endurance of 100,000 cycles and a minimum data retention of 100 years.

The device is designed to interface directly with the synchronous Serial Peripheral Interface (SPI) of many popular microcontroller families.

The device monitors the bus and asserts  $\overline{\text{RESET}}$  output if the watchdog timer is enabled and there is no bus activity within the user selectable time out period or the supply voltage falls below a preset minimum  $V_{\text{TRIP}}$ .

The device contains an 8-bit instruction register. It is accessed via the SI input, with data being clocked in on the rising edge of SCK.  $\overline{\text{CS}}$  must be LOW during the entire operation.

All instructions (Table 1), addresses and data are transferred MSB first. Data input on the SI line is latched on the first rising edge of SCK after  $\overline{\text{CS}}$  goes LOW. Data is output on the SO line by the falling edge of SCK. SCK is static, allowing the user to stop the clock and then start it again to resume operations where left off.

### Write Enable Latch

The device contains a Write Enable Latch. This latch must be SET before a Write Operation is initiated. The WREN instruction will set the latch and the WRDI instruction will reset the latch (Figure 7). This latch is automatically reset upon a power-up condition and after the completion of a valid Write Cycle.

### Status Register

The RDSR instruction provides access to the status register. The status register may be read at any time, even during a write cycle. The status register is formatted as follows.

### Status Register/Block Lock/WDT Byte

7	6	5	4	3	2	1	0
0	0	0	WD1	WD0	BL2	BL1	BL0

### Block Lock Memory

Intersil's block lock memory provides a flexible mechanism to store and lock system ID and parametric information. There are seven distinct block lock memory areas within the array which vary in size from one page to as much as half of the entire array. These areas and associated address ranges are block locked by writing the appropriate two byte block lock instruction to the device as described in Table 1 and Figure 9. Once a block lock instruction has been completed, that block lock setup is held in the nonvolatile status register until the next block lock instruction is issued. The sections of the memory array that are block locked can be read but not written until block lock is removed or changed.

TABLE 1. INSTRUCTION SET AND BLOCK LOCK PROTECTION BYTE DEFINITION

INSTRUCTION FORMAT	INSTRUCTION NAME AND OPERATION
0000 0110	WREN: set the write enable latch (write enable operation)
0000 0100	WRDI: reset the write enable latch (write disable operation)
0000 0001	<b>Write status instruction—followed by:</b> <b>Block lock/WDT byte: (See Figure 1)</b> 000WD <sub>1</sub> WD <sub>2</sub> 000 --->no block lock: 00h-00h--->none of the array 000WD <sub>1</sub> WD <sub>2</sub> 001 --->block lock Q1: 0000h-00FFh--->lower quadrant (Q1) 000WD <sub>1</sub> WD <sub>2</sub> 010 --->block lock Q2: 0100h-01FFh--->Q2 000WD <sub>1</sub> WD <sub>2</sub> 011 --->block lock Q3: 0200h-02FFh--->Q3 000WD <sub>1</sub> WD <sub>2</sub> 100 --->block lock Q4: 0300h-03FFh--->upper quadrant (Q4) 000WD <sub>1</sub> WD <sub>2</sub> 101 --->block lock H1: 0000h-01FFh--->lower half of the array (H1) 000WD <sub>1</sub> WD <sub>2</sub> 110 --->block lock P0: 0000h-000Fh--->lower page (P0) 000WD <sub>1</sub> WD <sub>2</sub> 111 --->block lock Pn: 03F0h-03FFh--->upper page (PN)
0000 0101	READ STATUS: reads status register & provides write in progress status on SO pin
0000 0010	WRITE: write operation followed by address and data
0000 0011	READ: read operation followed by address

### Watchdog Timer

The watchdog timer bits, WD0 and WD1, select the watchdog time out period. These nonvolatile bits are programmed with the WRSR instruction. A change to the Watchdog Timer, either setting a new time out period or turning it off or on, takes effect, following either the next command (read or write) or cycling the power to the device.

The recommended procedure for changing the Watch-dog Timer settings is to do a WREN, followed by a write status register command. Then execute a soft-ware loop to read the status register until the MSB of the status byte is zero. A valid alternative is to do a WREN, followed by a write status register command. Then wait 10ms and do a read status command.

TABLE 2. WATCHDOG TIMER DEFINITION

STATUS REGISTER BITS		WATCHDOG TIME OUT (TYPICAL)
WD1	WD0	
0	0	1.4s
0	1	600ms
1	0	200ms
1	1	disabled (factory default)

### Read Sequence

When reading from the EEPROM memory array,  $\overline{CS}$  is first pulled low to select the device. The 8-bit READ instruction is transmitted to the device, followed by the 16-bit address. After the READ opcode and address are sent, the data stored in the memory at the selected address is shifted out on the SO line. The data stored in memory at the next address can be read sequentially by continuing to provide clock pulses. The address is automatically incremented to the next higher address after each byte of data is shifted out. When the highest address is reached, the address counter rolls over to address \$0000 allowing the read cycle to be continued indefinitely. The read operation is terminated by taking  $\overline{CS}$  high. Refer to the read EEPROM array sequence (Figure 5).

To read the status register, the  $\overline{CS}$  line is first pulled low to select the device followed by the 8-bit RDSR instruction. After the RDSR opcode is sent, the contents of the status register are shifted out on the SO line. Refer to the read status register sequence (Figure 6).

### Write Sequence

Prior to any attempt to write data into the device, the "Write Enable" Latch (WEL) must first be set by issuing the WREN instruction (Figure 7).  $\overline{CS}$  is first taken LOW, then the WREN instruction is clocked into the device. After all eight bits of the instruction are transmitted,  $\overline{CS}$  must then be taken HIGH. If the user continues the write operation without taking  $\overline{CS}$  HIGH after issuing the WREN instruction, the write operation will be ignored.

To write data to the EEPROM memory array, the user then issues the WRITE instruction followed by the 16 bit address and then the data to be written. Any unused address bits are specified to be "0's". The WRITE operation minimally takes 32 clocks.  $\overline{CS}$  must go low and remain low for the duration of the operation. If the address counter reaches the end of a page and the clock continues, the counter will roll back to the first address of the same page and overwrite any data that may have been previously written.

For a write operation (byte or page write) to be completed,  $\overline{CS}$  can only be brought HIGH after bit 0 of the last data byte to be written is clocked in. If it is brought HIGH at any other time, the write operation will not be completed (Figure 8).

To write to the status register, the WRSR instruction is followed by the data to be written (Figure 9). Data bits 5, 6 and 7 must be "0".

### Read Status Operation

If there is not a nonvolatile write in progress, the read status instruction returns the block lock setting from the status register which contains the watchdog timer bits WD1, WD0, and the block lock bits IDL2-IDL0 (Figure 6). The block lock bits define the block lock condition (Table 1). The watchdog timer bits set the operation of the watchdog timer (Table 2). The other bits are reserved and will return '0' when read. See Figure 6.

During an internal nonvolatile write operation, the Read Status Instruction returns a HIGH on SO in the first bit following the RDSR instruction (the MSB). The remaining bits in the output status byte are undefined. Repeated Read Status Instructions return the MSB as a '1' until the nonvolatile write cycle is complete. When the nonvolatile write cycle is completed, the RDSR instruction returns a '0' in the MSB position with the remaining bits of the status register undefined. Subsequent RDSR instructions return the Status Register Contents. See Figure 10.

### RESET Operation

The  $\overline{RESET}$  output is designed to go LOW whenever  $V_{CC}$  has dropped below the minimum trip point and/or the watchdog timer has reached its programmable time out limit.

The  $\overline{RESET}$  output is an open drain output and requires a pull up resistor.

### Operational Notes

The device powers-up in the following state:

- The device is in the low power standby state.
- A HIGH to LOW transition on  $\overline{CS}$  is required to enter an active state and receive an instruction.
- SO pin is high impedance.
- The write enable latch is reset.
- Reset signal is active for  $t_{PURST}$ .



**Data Protection**

The following circuitry has been included to prevent inadvertent writes:

- A WREN instruction must be issued to set the write enable latch.
- $\overline{CS}$  must come HIGH at the proper clock count in order to start a nonvolatile write cycle.
- When  $V_{CC}$  is below  $V_{TRIP}$ , communications to the device are inhibited.

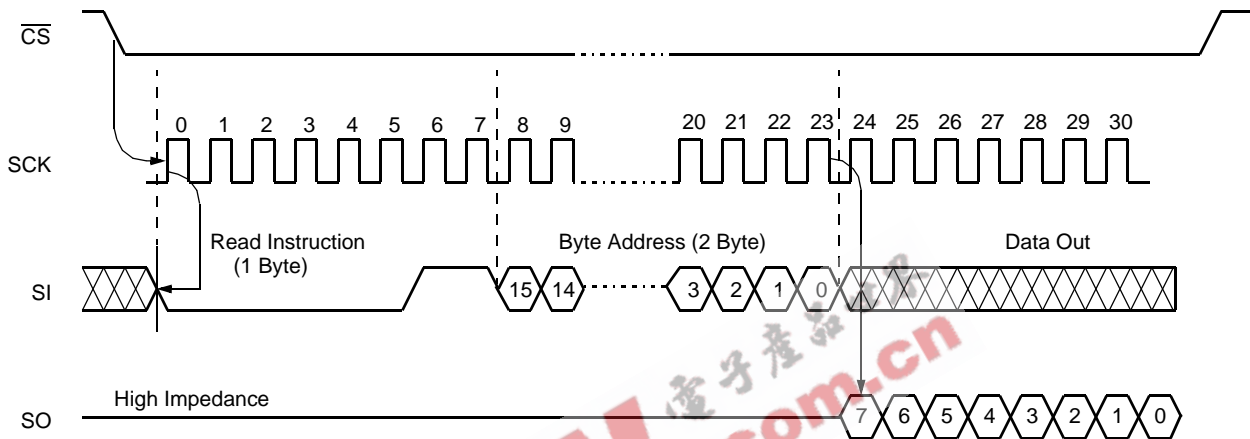

FIGURE 5. READ OPERATION SEQUENCE

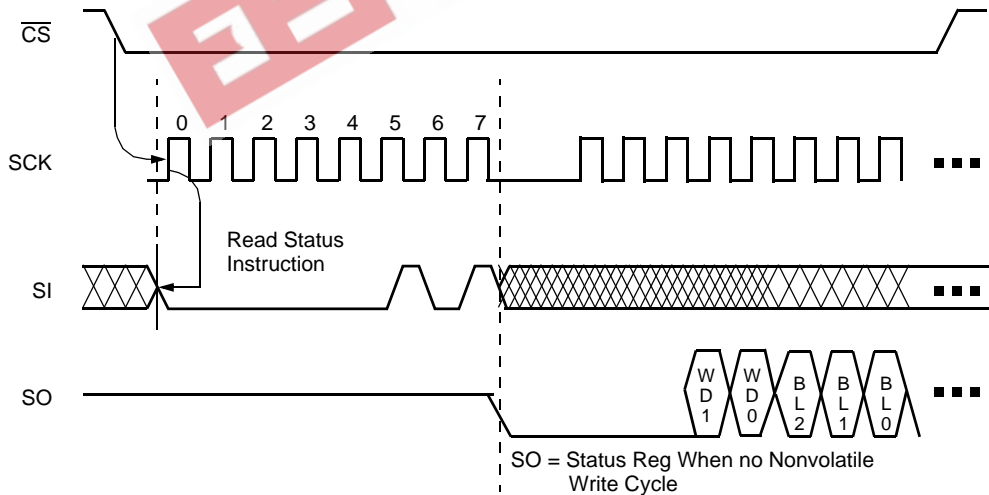

FIGURE 6. READ STATUS OPERATION SEQUENCE

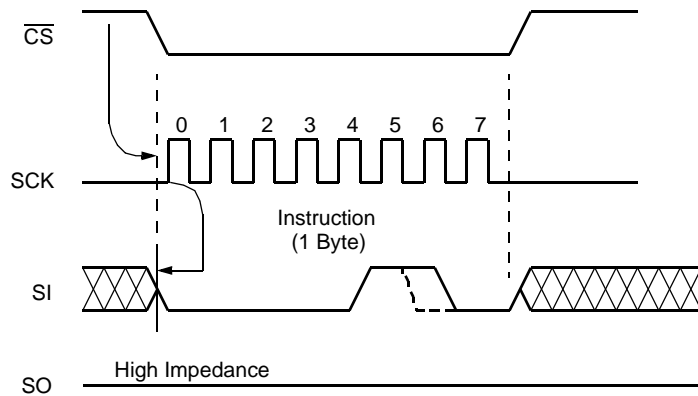

FIGURE 7. WREN/WRDI SEQUENCE

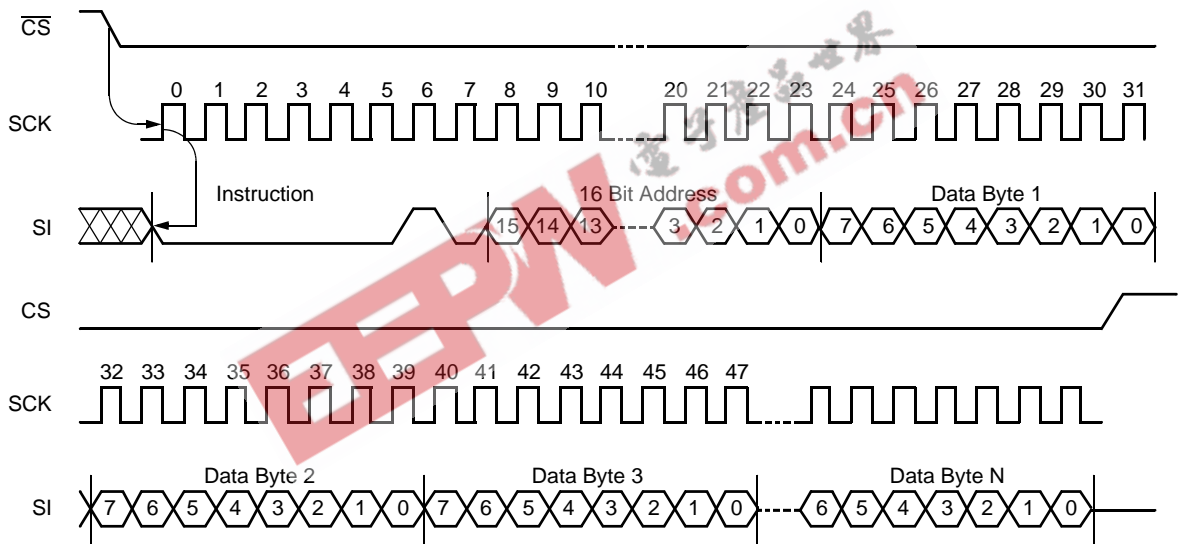

FIGURE 8. EEPROM ARRAY WRITE SEQUENCE

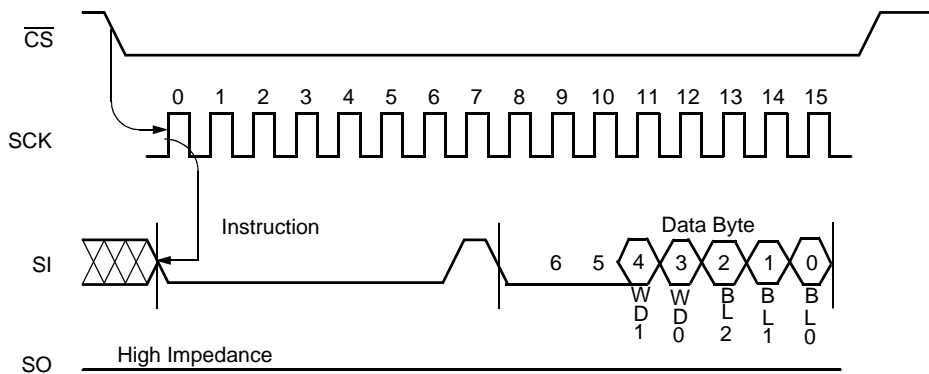

FIGURE 9. STATUS REGISTER WRITE SEQUENCE

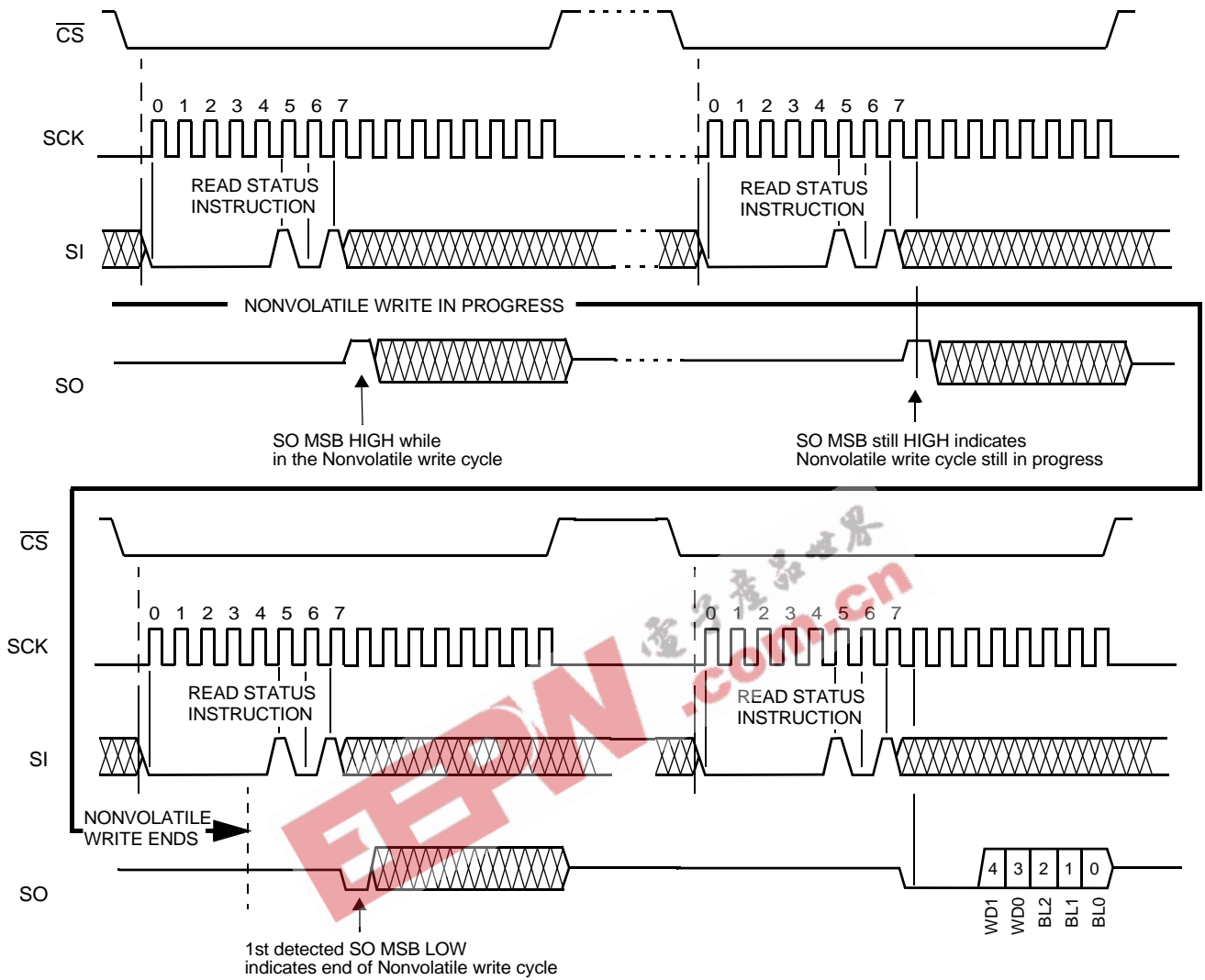

FIGURE 10. READ NONVOLATILE WRITE STATUS

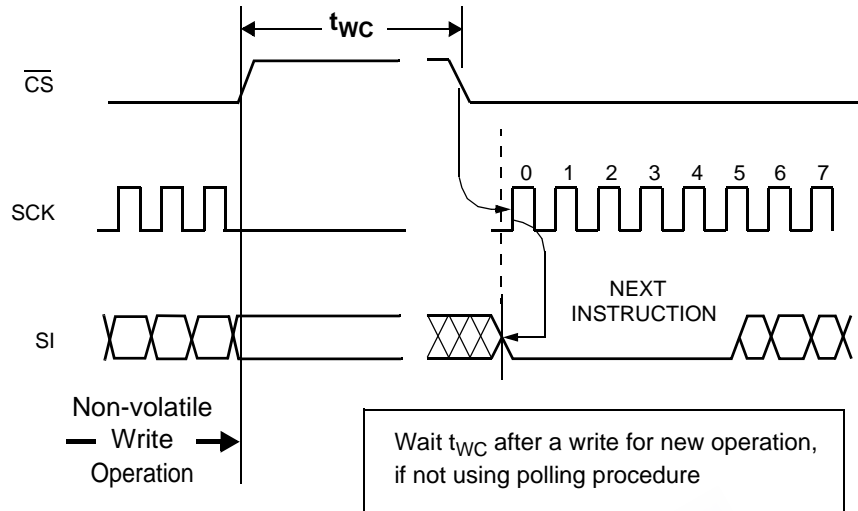

FIGURE 11. END OF NONVOLATILE WRITE (NO POLLING)

Symbol Table

WAVEFORM	INPUTS	OUTPUTS
	Must be steady	Will be steady
	May change from LOW to HIGH	Will change from LOW to HIGH
	May change from HIGH to LOW	Will change from HIGH to LOW
	Don't Care: Changes Allowed	Changing: State Not Known
	N/A	Center Line is High Impedance

## X5083

### Absolute Maximum Ratings

Temperature Under Bias	-65°C to 135°C
Storage Temperature	-65°C to 150°C
Voltage on Any Pin with Respect To $V_{SS}$	-1.0V to 7V
D.C. Output Current	5mA
Lead Temperature (Soldering, 10s)	300°C

### Operating Conditions

Temperature Range	Commercial	0°C to 70°C
	Industrial	-40°C to 85°C
$V_{CC}$ Range		
	-2.7	2.7V to 5.5V
	Blank	4.5V to 5.5V

**CAUTION:** Stresses above those listed in "Absolute Maximum Ratings" may cause permanent damage to the device. This is a stress only rating and operation of the device at these or any other conditions above those indicated in the operational sections of this specification is not implied.

### DC Electrical Specifications (Over the recommended operating conditions unless otherwise specified.)

SYMBOL	PARAMETER	TEST CONDITIONS	LIMITS			UNIT
			MIN	TYP	MAX	
$I_{CC1}$	$V_{CC}$ Write Current (Active)	SCK = $V_{CC} \times 0.1/V_{CC} \times 0.9$ @ 5MHz, SO = Open			5	mA
$I_{CC2}$	$V_{CC}$ Read Current (Active)	SCK = $V_{CC} \times 0.1/V_{CC} \times 0.9$ @ 5MHz, SO = Open			0.4	mA
$I_{SB1}$	$V_{CC}$ Standby Current WDT = OFF	$\overline{CS} = V_{CC}$ , $V_{IN} = V_{SS}$ or $V_{CC}$ , $V_{CC} = 5.5V$			1	$\mu A$
$I_{SB2}$	$V_{CC}$ Standby Current WDT = ON	$\overline{CS} = V_{CC}$ , $V_{IN} = V_{SS}$ or $V_{CC}$ , $V_{CC} = 5.5V$			50	$\mu A$
$I_{SB3}$	$V_{CC}$ Standby Current WDT = ON	$\overline{CS} = V_{CC}$ , $V_{IN} = V_{SS}$ or $V_{CC}$ , $V_{CC} = 3.6V$			20	$\mu A$
$I_{LI}$	Input Leakage Current	$V_{IN} = V_{SS}$ to $V_{CC}$		0.1	10	$\mu A$
$I_{LO}$	Output Leakage Current	$V_{OUT} = V_{SS}$ to $V_{CC}$		0.1	10	$\mu A$
$V_{IL}$ (Note 1)	Input LOW Voltage		-0.5		$V_{CC} \times 0.3$	V
$V_{IH}$ (Note 1)	Input HIGH Voltage		$V_{CC} \times 0.7$		$V_{CC} + 0.5$	V
$V_{OL1}$	Output LOW Voltage	$V_{CC} > 3.3V$ , $I_{OL} = 2.1mA$			0.4	V
$V_{OL2}$	Output LOW Voltage	$2V < V_{CC} \leq 3.3V$ , $I_{OL} = 1mA$			0.4	V
$V_{OL3}$	Output LOW Voltage	$V_{CC} \leq 2V$ , $I_{OL} = 0.5mA$			0.4	V
$V_{OH1}$	Output HIGH Voltage	$V_{CC} > 3.3V$ , $I_{OH} = -1.0mA$	$V_{CC} - 0.8$			V
$V_{OH2}$	Output HIGH Voltage	$2V < V_{CC} \leq 3.3V$ , $I_{OH} = -0.4mA$	$V_{CC} - 0.4$			V
$V_{OH3}$	Output HIGH Voltage	$V_{CC} \leq 2V$ , $I_{OH} = -0.25mA$	$V_{CC} - 0.2$			V
$V_{OLRS}$	Reset Output LOW Voltage	$I_{OL} = 1mA$			0.4	V

### Power-Up Timing

SYMBOL	PARAMETER	MIN	MAX	UNIT
$t_{PUR}$ (Note 2)	Power-up to read operation		1	ms
$t_{PUW}$ (Note 2)	Power-up to write operation		5	ms

### Capacitance $T_A = +25^\circ C$ , $f = 1MHz$ , $V_{CC} = 5V$

SYMBOL	TEST	MAX	UNIT	CONDITIONS
$C_{OUT}$ (Note 2)	Output capacitance (SO, $\overline{RESET}$ , RESET)	8	pF	$V_{OUT} = 0V$
$C_{IN}$ (Note 2)	Input capacitance (SCK, SI, $\overline{CS}$ , $\overline{WP}$ )	6	pF	$V_{IN} = 0V$

#### NOTES:

- $V_{IL}$  min. and  $V_{IH}$  max. are for reference only and are not tested.
- This parameter is periodically sampled and not 100% tested.

## X5083

### Equivalent A.C. Load Circuit at 5V $V_{CC}$

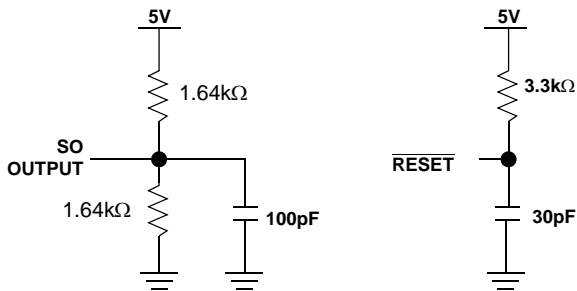

### A.C. Test Conditions

Input pulse levels	$V_{CC} \times 0.1$ to $V_{CC} \times 0.9$
Input rise and fall times	10ns
Input and output timing level	$V_{CC} \times 0.5$

### AC Electrical Specifications (Over recommended operating conditions, unless otherwise specified)

SYMBOL	PARAMETER	2.7V-5.5V		UNIT
		MIN	MAX	
<b>DATA INPUT TIMING</b>				
$f_{SCK}$	Clock frequency	0	3.3	MHz
$t_{CYC}$	Cycle time	300		ns
$t_{LEAD}$	$\overline{CS}$ lead time	150		ns
$t_{LAG}$	$\overline{CS}$ lag time	150		ns
$t_{WH}$	Clock HIGH time	130		ns
$t_{WL}$	Clock LOW time	130		ns
$t_{SU}$	Data setup time	20		ns
$t_H$	Data hold time	20		ns
$t_{RI}$ (Note 3)	Input rise time		2	$\mu s$
$t_{FI}$ (Note 3)	Input fall time		2	$\mu s$
$t_{CS}$	$\overline{CS}$ deselect time	100		ns
$t_{WC}$ (Note 4)	Write cycle time		10	ms
<b>DATA OUTPUT TIMING</b>				
$f_{SCK}$	Clock frequency	0	3.3	MHz
$t_{DIS}$	Output disable time		150	ns
$t_V$	Output valid from clock low		130	ns
$t_{HO}$	Output hold time	0		ns
$t_{RO}$ (Note 3)	Output rise time		50	ns
$t_{FO}$ (Note 3)	Output fall time		50	ns

#### NOTES:

- This parameter is periodically sampled and not 100% tested.
- $t_{WC}$  is the time from the rising edge of  $\overline{CS}$  after a valid write sequence has been sent to the end of the self-timed internal nonvolatile write cycle.

**Serial Output Timing**

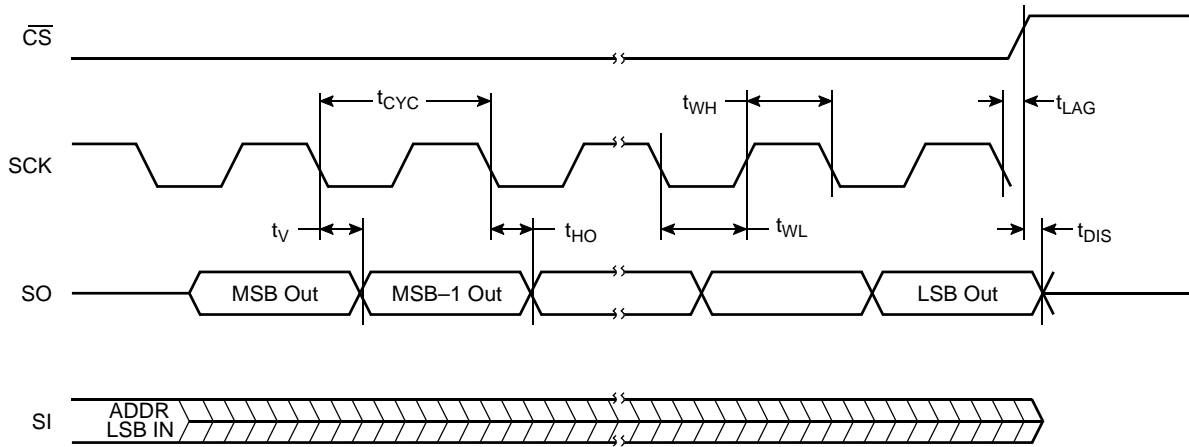

**Serial Input Timing**

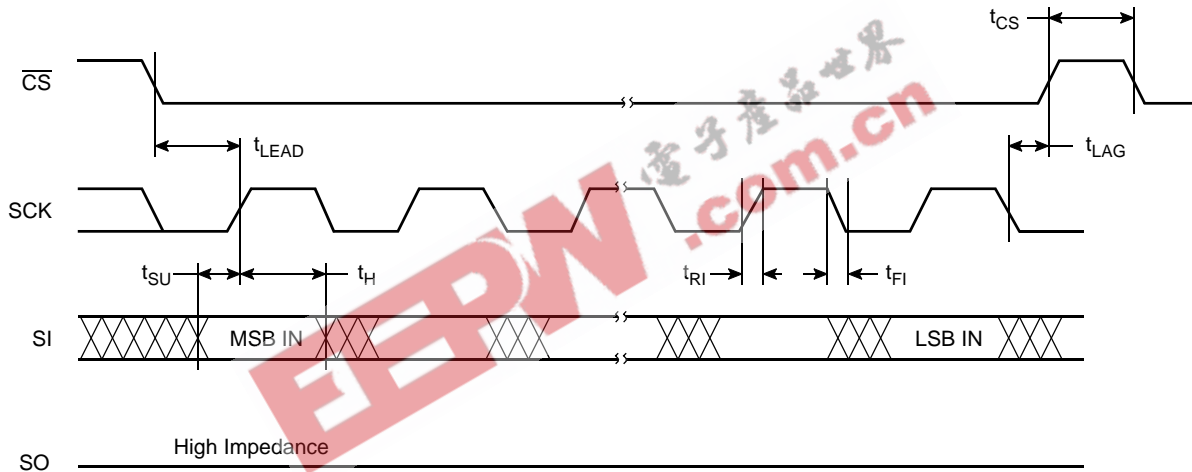

**Power-Up and Power-Down Timing**

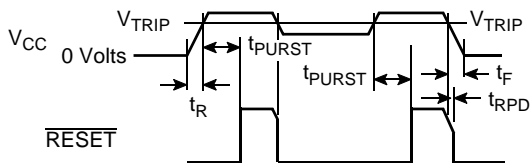

## X5083

### RESET Output Timing

SYMBOL	PARAMETER	MIN	TYP	MAX	UNIT
$V_{TRIP}$	Reset trip point voltage, X5083PT-4.5A (Note 6)	4.5	4.63	4.75	V
	Reset trip point voltage, X5083PT	4.25	4.38	4.5	
	Reset trip point voltage, X5083PT-2.7A	2.85	2.93	3.00	
	Reset trip point voltage, X5083PT-2.7	2.55	2.63	2.7	
$t_{PURST}$	Power-up reset time out	100	200	280	ms
$t_{RPD}$ (Note 5)	$V_{CC}$ detect to reset/output			500	ns
$t_F$ (Note 5)	$V_{CC}$ fall time	0.1			ns
$t_R$ (Note 5)	$V_{CC}$ rise time	0.1			ns
$V_{RVALID}$	Reset valid $V_{CC}$	1			V

NOTES:

5. This parameter is periodically sampled and not 100% tested.
6. PT = Package/Temperature

### $\overline{CS}$ vs. $\overline{RESET}$ Timing

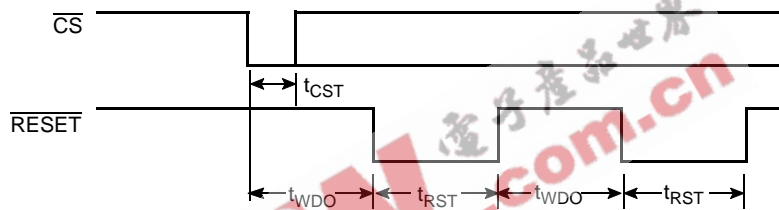

### RESET Output Timing

SYMBOL	PARAMETER	MIN	TYP	MAX	UNIT
$t_{WDO}$	Watchdog time out period, WD1 = 1, WD0 = 1(default)		OFF		
	WD1 = 1, WD0 = 0	100	200	300	ms
	WD1 = 0, WD0 = 1	450	600	800	ms
	WD1 = 0, WD0 = 0	1	1.4	2	sec
$t_{CST}$	$\overline{CS}$ pulse width to reset the watchdog	400			ns
$t_{RST}$	Reset time out	100	200	300	ms



## X5083

### $V_{TRIP}$ Programming Timing Diagram

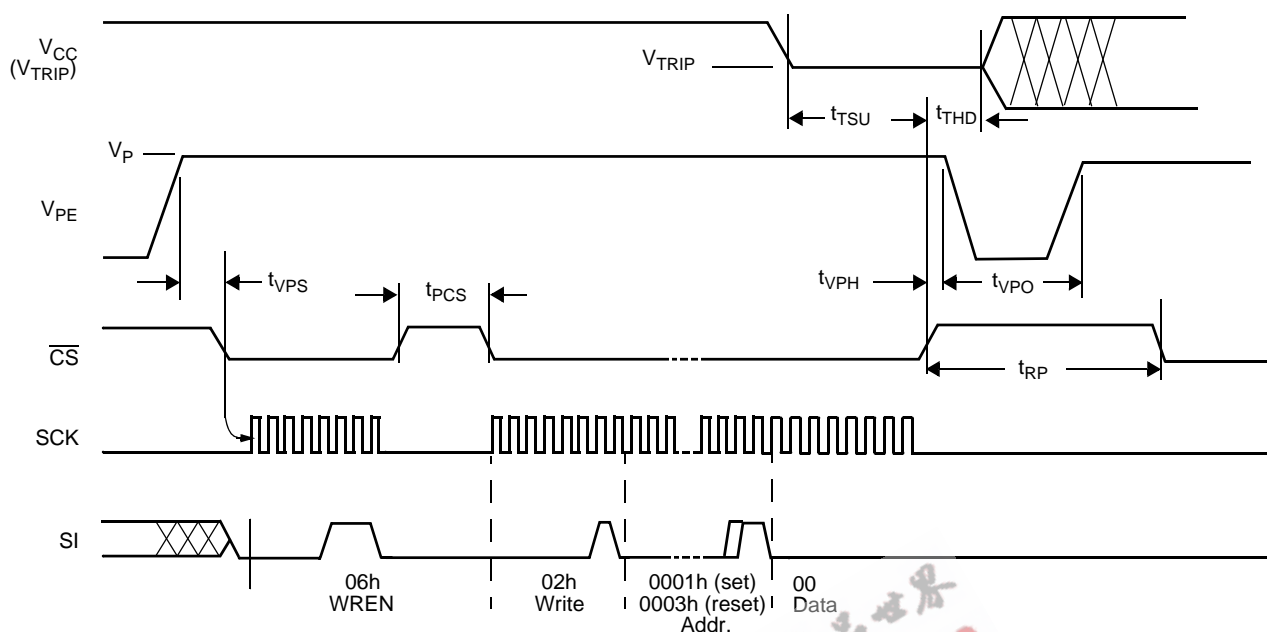

### $V_{TRIP}$ Programming Parameters

PARAMETER	DESCRIPTION	MIN	MAX	UNIT
$t_{VPS}$	$V_{TRIP}$ program enable voltage setup time	1		$\mu s$
$t_{VPH}$	$V_{TRIP}$ program enable voltage hold time	1		$\mu s$
$t_{PCS}$	$V_{TRIP}$ programming $\overline{CS}$ inactive time	1		$\mu s$
$t_{TSU}$	$V_{TRIP}$ setup time	1		$\mu s$
$t_{THD}$	$V_{TRIP}$ hold (stable) time	10		ms
$t_{WC}$	$V_{TRIP}$ write cycle time		10	ms
$t_{VPO}$	$V_{TRIP}$ program enable voltage off time (between successive adjustments)	0		$\mu s$
$t_{RP}$	$V_{TRIP}$ program recovery period (between successive adjustments)	10		ms
$V_P$	Programming voltage	15	18	V
$V_{TRAN}$	$V_{TRIP}$ programmed voltage range	2.0	5.0	V
$V_{TV}$	$V_{TRIP}$ program variation after programming (0-75°C). (programmed at 25°C)	-25	+25	mV

#### NOTES:

7.  $V_{TRIP}$  programming parameters are periodically sampled and are not 100% tested.
8. For custom  $V_{TRIP}$  settings, Contact Factory.

# X5083

## Packaging Information

### 8-Lead Plastic Dual In-Line Package Type P

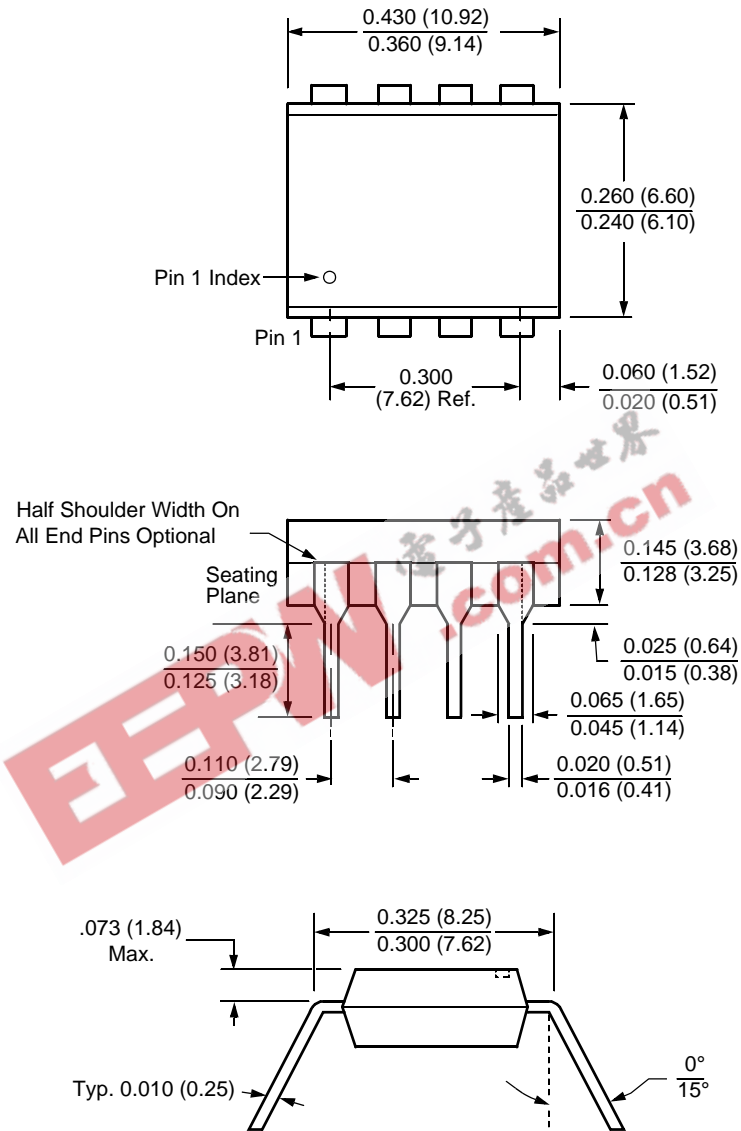

**NOTE:**

1. ALL DIMENSIONS IN INCHES (IN PARENTHESES IN MILLIMETERS)
2. PACKAGE DIMENSIONS EXCLUDE MOLDING FLASH

# X5083

## Packaging Information

### 8-Lead Plastic Small Outline Gull Wing Package Type S

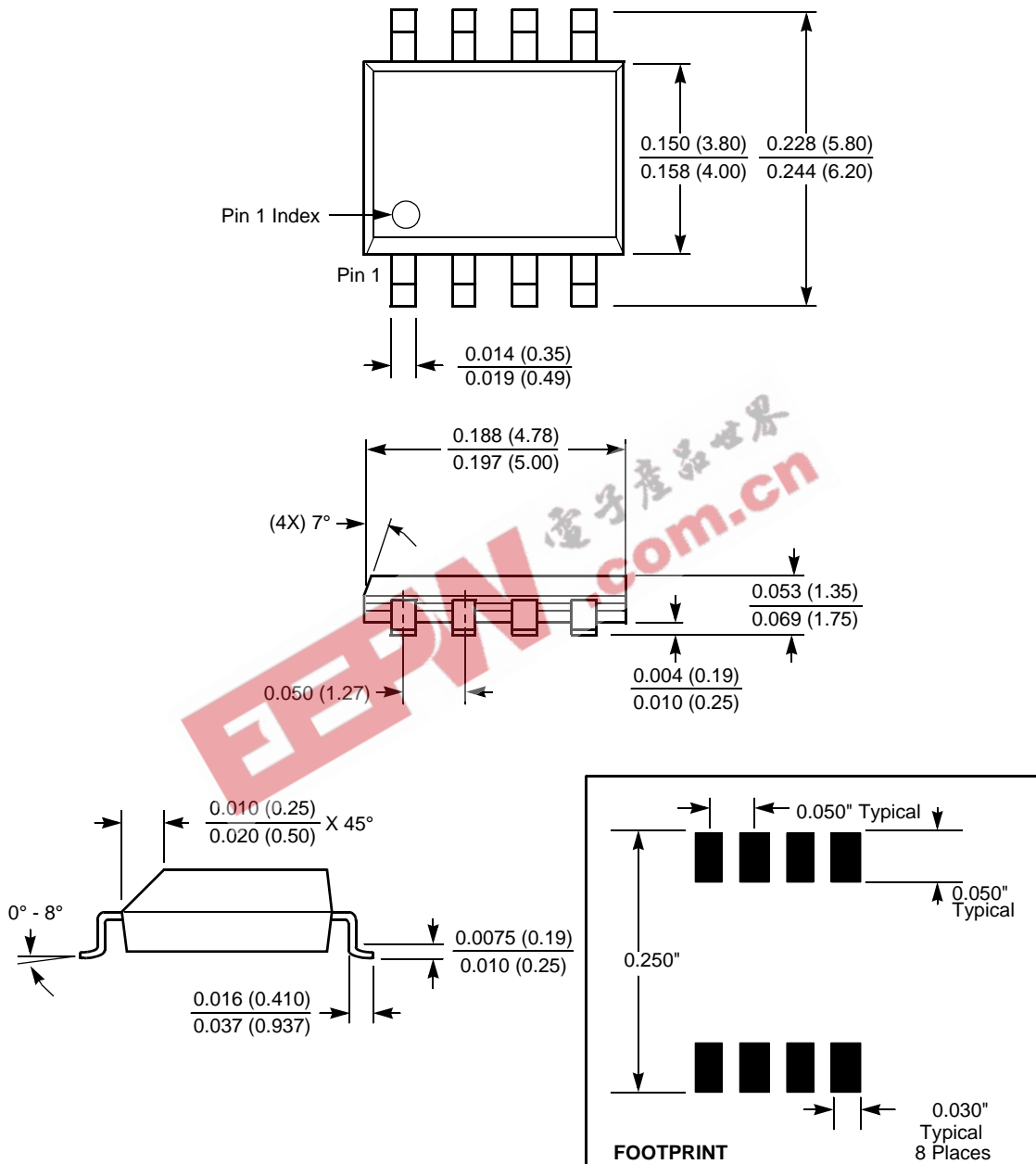

NOTE: ALL DIMENSIONS IN INCHES (IN PARENTHESES IN MILLIMETERS)

# X5083

## Packaging Information

### 8-Lead Plastic, TSSOP, Package Type V

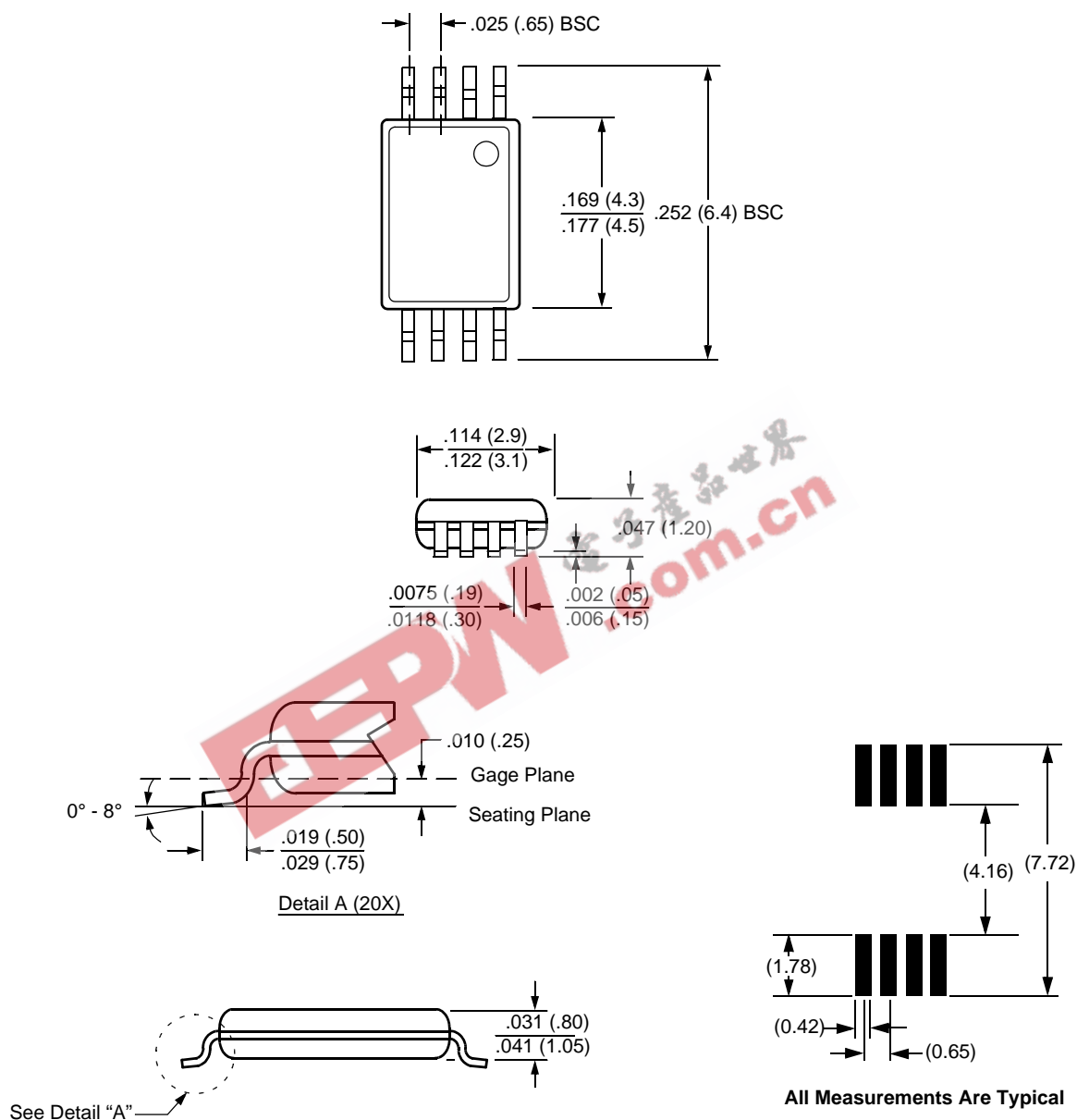

**NOTE: ALL DIMENSIONS IN INCHES (IN PARENTHESES IN MILLIMETERS)**

All Intersil U.S. products are manufactured, assembled and tested utilizing ISO9000 quality systems. Intersil Corporation's quality certifications can be viewed at [www.intersil.com/design/quality](http://www.intersil.com/design/quality)

*Intersil products are sold by description only. Intersil Corporation reserves the right to make changes in circuit design, software and/or specifications at any time without notice. Accordingly, the reader is cautioned to verify that data sheets are current before placing orders. Information furnished by Intersil is believed to be accurate and reliable. However, no responsibility is assumed by Intersil or its subsidiaries for its use; nor for any infringements of patents or other rights of third parties which may result from its use. No license is granted by implication or otherwise under any patent or patent rights of Intersil or its subsidiaries.*

For information regarding Intersil Corporation and its products, see [www.intersil.com](http://www.intersil.com)