

X9015

Digitally-Controlled Potentiometer

FEATURES

- 32 Taps
- Three-wire Up/Down Serial Interface
- $V_{CC} = 2.7V \text{ \& } 5V$
- Operating $I_{CC} = 50\mu A \text{ Max.}$
- Standby current = $1\mu A \text{ Max.}$
- $R_{TOTAL} = 50K\Omega$
- Packages, SOIC-8

DESCRIPTION

The Xicor X9015 is a 32 tap potentiometer that is volatile. The device consists of a string of 31 resistors that can be programmed to connect the R_W/V_W wiper output with any of the nodes between the connecting resistors. The connection point of the wiper is determined by information communicated to the device on the 3-wire port. The 3-wire port changes the tap position by a falling edge on the increment pin. Direction of the wiper moves is determined by the state of the Up/Down pin. The wiper position at power up is tap #15.

The X9015 can be used in a wide variety of applications that require a digitally controlled variable resistor to set analog values.

FUNCTIONAL DIAGRAMS

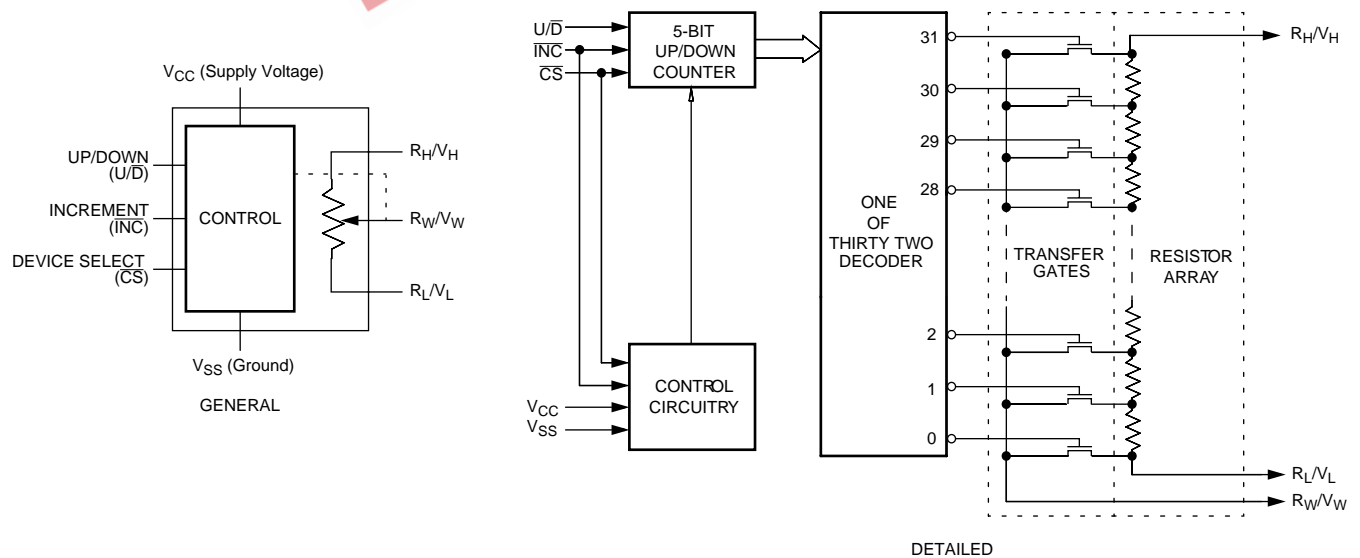

X9015

PIN DESCRIPTIONS

R_H/V_H and R_L/V_L

The high (R_H/V_H) and low (R_L/V_L) terminals of the X9015 are equivalent to the fixed terminals of a mechanical potentiometer. The minimum voltage is V_{SS} and the maximum is V_{CC} . The terminology of R_L/V_L and R_H/V_H references the relative position of the terminal in relation to wiper movement direction selected by the U/\bar{D} input and not the voltage potential on the terminal.

R_W/V_W

R_W/V_W is the wiper terminal and is equivalent to the movable terminal of a mechanical potentiometer. The position of the wiper within the array is determined by the control inputs. The wiper terminal series resistance is typically 200Ω at $V_{CC} = 5V$. At power up the wiper position is at tap #15 ($V_L/R_L = \text{tap \#0}$).

Up/Down (U/\bar{D})

The U/\bar{D} input controls the direction of the wiper movement and whether the tap position is incremented or decremented.

Increment (\bar{INC})

The \bar{INC} input is negative-edge triggered. Toggling \bar{INC} will move the wiper and either increment or decrement the counter in the direction indicated by the logic level on the U/\bar{D} input.

Chip Select (\bar{CS})

The device is selected when the \bar{CS} input is LOW. When \bar{CS} is returned HIGH while the \bar{INC} input is LOW the X9015 will be placed in the low power standby mode until the device is selected once again.

PIN CONFIGURATION

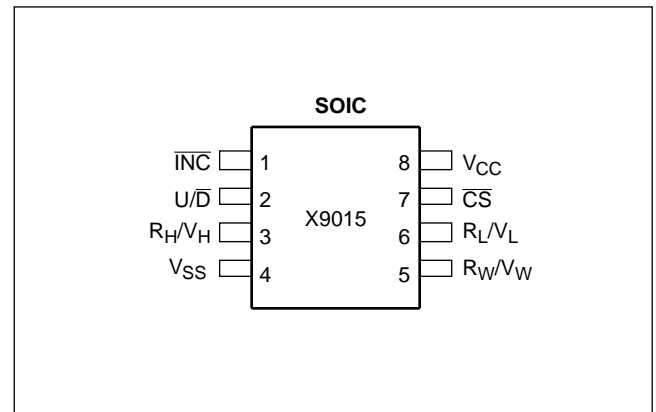

PIN NAMES

Symbol	Description
R_H/V_H	High Terminal
R_W/V_W	Wiper Terminal
R_L/V_L	Low Terminal
V_{SS}	Ground
V_{CC}	Supply Voltage
U/\bar{D}	Up/Down Control Input
\bar{INC}	Increment Control Input
\bar{CS}	Chip Select Control Input

X9015

PRINCIPLES OF OPERATION

There are two sections of the X9015: the input control, counter and decode section; and the resistor array. The input control section operates just like an up/down counter. The output of this counter is decoded to turn on a single electronic switch connecting a point on the resistor array to the wiper output. The resistor array is comprised of 31 individual resistors connected in series.

The wiper, when at either fixed terminal, acts like its mechanical equivalent and does not move beyond the last position. That is, the counter does not wrap around when clocked to either extreme.

The electronic switches on the device operate in a “make before break” mode when the wiper changes tap positions. If the wiper is moved several positions, multiple taps are connected to the wiper for t_{IW} (INC to V_W change). The R_{TOTAL} value for the device can temporarily be reduced by a significant amount if the wiper is moved several positions.

When the device is powered-down, the wiper position is lost. When power is restored, the wiper is set to tap #15.

INSTRUCTIONS AND PROGRAMMING

The \overline{INC} , U/\overline{D} and \overline{CS} inputs control the movement of the wiper along the resistor array. With \overline{CS} set LOW the device is selected and enabled to respond to the U/\overline{D} and \overline{INC} inputs. HIGH to LOW transitions on \overline{INC} will increment or decrement (depending on the state of the U/\overline{D} input) a five bit counter. The output of this counter is decoded to select one of thirty two wiper positions along the resistive array.

The system may select the X9015, move the wiper and deselect the device. The new wiper position will be maintained until changed by the system or until a power-up/down cycle.

The state of U/\overline{D} may be changed while \overline{CS} remains LOW. This allows the host system to enable the device and then move the wiper up and down until the proper trim is attained.

MODE SELECTION

\overline{CS}	\overline{INC}	U/\overline{D}	Mode
L		H	Wiper Up
L		L	Wiper Down
H	X	X	Standby Current
	L	X	Return to standby

SYMBOL TABLE

WAVEFORM	INPUTS	OUTPUTS
	Must be steady	Will be steady
	May change from Low to High	Will change from Low to High
	May change from High to Low	Will change from High to Low
	Don't Care: Changes Allowed	Changing: State Not Known
	N/A	Center Line is High Impedance

X9015

ABSOLUTE MAXIMUM RATINGS*

Temperature under Bias -65°C to +135°C
 Storage Temperature -65°C to +150°C
 Voltage on CS, INC, U/D, V_H, V_L and V_{CC}
 with Respect to V_{SS}..... -1V to +7V
 $\Delta V = |V_H - V_L|$ 5V
 Lead Temperature (Soldering 10 seconds)..... 300°C

*COMMENT

Stresses above those listed under “Absolute Maximum Ratings” may cause permanent damage to the device. This is a stress rating only and the functional operation of the device at these or any other conditions above those listed in the operational sections of this specification is not implied. Exposure to absolute maximum rating conditions for extended periods may affect device reliability.

RECOMMENDED OPERATING CONDITIONS

Temperature	Min.	Max.
Commercial	0°C	+70°C
Industrial	-40°C	+85°C

Supply Voltage (V _{CC})	Limits
X9015	5V ±10%
X9015-2.7V	2.7V to 5.5V

POTENTIOMETER CHARACTERISTICS (Over recommended operating conditions unless otherwise stated.)

Symbol	Parameter	Limits				Test Conditions/Notes
		Min.	Typ.	Max.	Units	
R _{TOTAL}	End to End Resistance Variation	-20		+20	%	
V _{VH}	V _H Terminal Voltage	0		V _{CC}	V	
V _{VL}	V _L Terminal Voltage	0		V _{CC}	V	
	Power Rating			10	mW	R _{TOTAL} ≤ 50KΩ
R _W	Wiper Resistance		200	400	Ω	I _W = 1mA, V _{CC} = 5V
R _W	Wiper Resistance		400	1000	Ω	I _W = 1mA, V _{CC} = 2.7V
I _W	Wiper Current			±1	mA	
	Noise		-120		dBV	Ref: 1kHz
	Resolution		3		%	
	Absolute Linearity ⁽¹⁾	-1		+1	MI ⁽³⁾	V _{w(n)(actual)} - V _{w(n)(expected)}
	Relative Linearity ⁽²⁾	-0.2		+0.2	MI ⁽³⁾	V _{w(n+1)} - [V _{w(n)} + MI]
	R _{TOTAL} Temperature Coefficient		±300		ppm/°C	
	Ratiometric Temperature Coefficient			±20	ppm/°C	
C _H /C _L /C _W	Potentiometer Capacitances		10/10/25		pF	See circuit #3

- Notes:**
- (1) Absolute Linearity is utilized to determine actual wiper voltage versus expected voltage = (V_{w(n)(actual)} - V_{w(n)(expected)}) = ±1 MI Maximum.
 - (2) Relative Linearity is a measure of the error in step size between taps = V_{w(n+1)} - [V_{w(n)} + MI] = ±0.2 MI.
 - (3) 1 MI = Minimum Increment = R_{TOT}/31.
 - (4) Typical values are for T_A = 25°C and nominal supply voltage.
 - (5) This parameter is periodically sampled and not 100% tested.

X9015

D.C. OPERATING CHARACTERISTICS (Over recommended operating conditions unless otherwise specified.)

Symbol	Parameter	Limits			Units	Test Conditions
		Min.	Typ.(4)	Max.		
I_{CC1}	V_{CC} Active Current (Increment)			50	μA	$\overline{CS} = V_{IL}$, $U/\overline{D} = V_{IL}$ or V_{IH} and $\overline{INC} = 0.4V$ @ max. t_{CYC}
I_{SB}	Standby Supply Current			1	μA	$\overline{CS} = V_{CC} - 0.3V$, U/\overline{D} and $\overline{INC} = V_{SS}$ or $V_{CC} - 0.3V$
I_{LI}	\overline{CS} , \overline{INC} , U/\overline{D} Input Leakage Current			± 10	μA	$V_{IN} = V_{SS}$ to V_{CC}
V_{IH}	\overline{CS} , \overline{INC} , U/\overline{D} Input HIGH Voltage	$V_{CC} \times 0.7$		$V_{CC} + 0.5$	V	
V_{IL}	\overline{CS} , \overline{INC} , U/\overline{D} Input LOW Voltage	-0.5		$V_{CC} \times 0.1$	V	
$C_{IN}^{(5)}$	\overline{CS} , \overline{INC} , U/\overline{D} Input Capacitance			10	pF	$V_{CC} = 5V$, $V_{IN} = V_{SS}$, $T_A = 25^\circ C$, $f = 1MHz$

Test Circuit #1

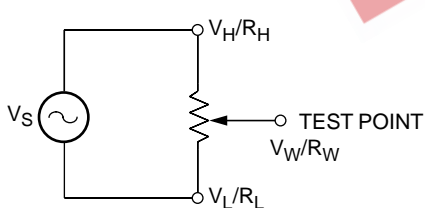

Test Circuit #2

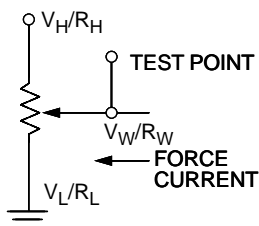

Circuit #3 SPICE Macromodel

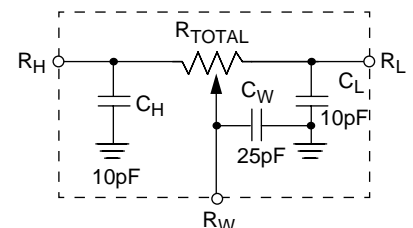

X9015

A.C. CONDITIONS OF TEST

Input Pulse Levels	0V to 3V
Input Rise and Fall Times	10ns
Input Reference Levels	1.5V

A.C. OPERATING CHARACTERISTICS (Over recommended operating conditions unless otherwise specified)

Symbol	Parameter	Limits			Units
		Min.	Typ.(6)	Max.	
t_{CI}	\overline{CS} to \overline{INC} Setup	100			ns
t_{ID}	\overline{INC} HIGH to U/\overline{D} Change	100			ns
t_{DI}	U/\overline{D} to \overline{INC} Setup	2.9			μ s
t_{IL}	\overline{INC} LOW Period	1			μ s
t_{IH}	\overline{INC} HIGH Period	1			μ s
t_{IC}	\overline{INC} Inactive to \overline{CS} Inactive	1			μ s
t_{CPH}	\overline{CS} Deselect Time	100			ns
t_{IW}	\overline{INC} to V_W Change		1	5	μ s
t_{CYC}	\overline{INC} Cycle Time	4			μ s
$t_R, t_F^{(7)}$	\overline{INC} Input Rise and Fall Time			500	μ s
$t_{PU}^{(7)}$	Power up to Wiper Stable			5	μ s
$t_R V_{CC}^{(7)}$	V_{CC} Power-up Rate	0.2		50	V/ms

A.C. TIMING

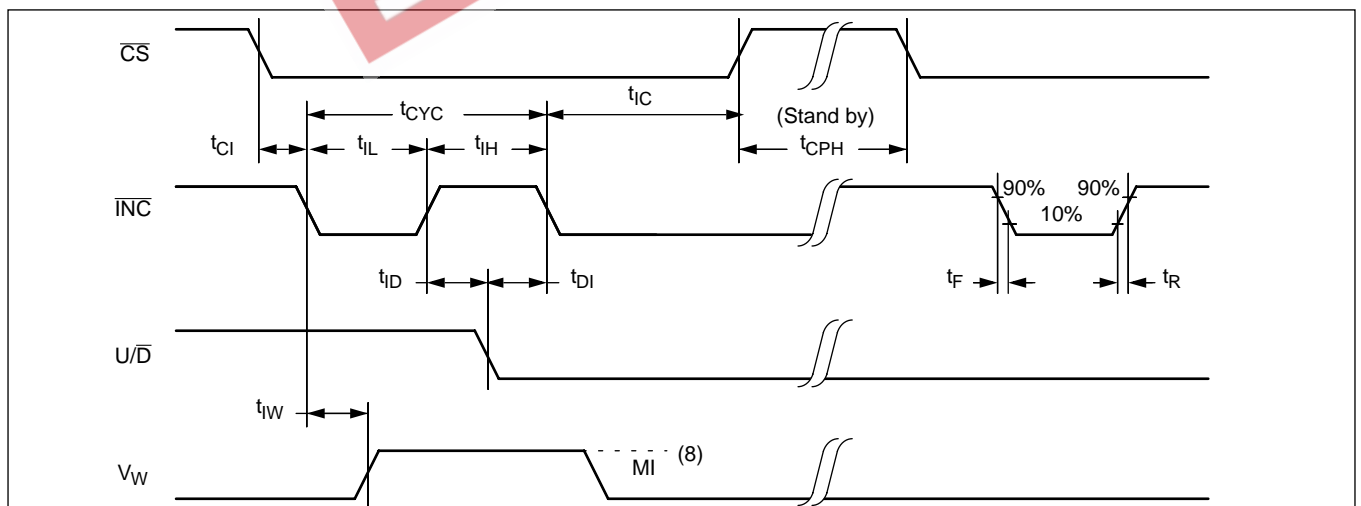

- Notes:** (6) Typical values are for $T_A = 25^\circ\text{C}$ and nominal supply voltage.
 (7) This parameter is periodically sampled and not 100% tested.
 (8) MI in the A.C. timing diagram refers to the minimum incremental change in the V_W output due to a change in the wiper position.

X9015

PERFORMANCE CHARACTERISTICS (TYPICAL) TYPICAL NOISE

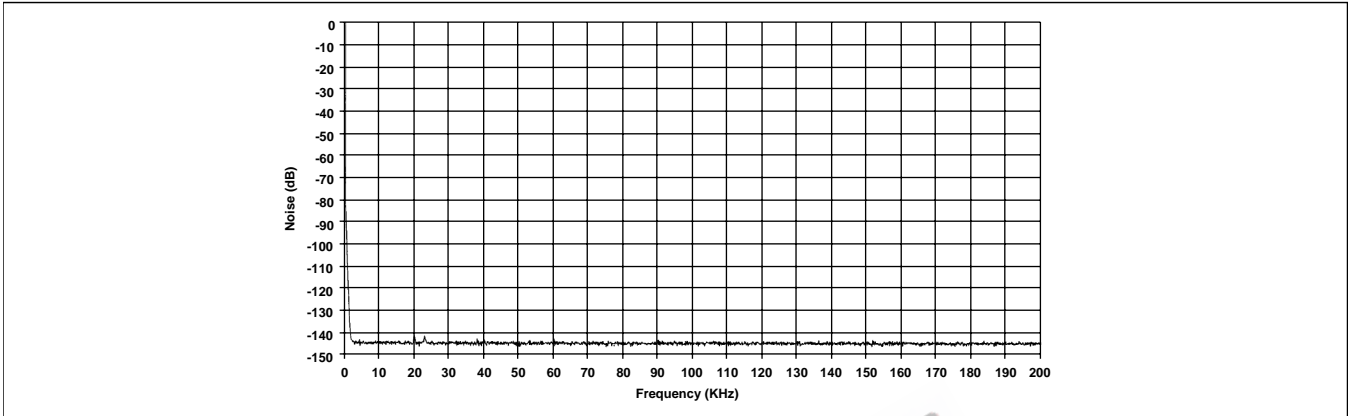

TYPICAL RTOTAL vs. TEMPERATURE

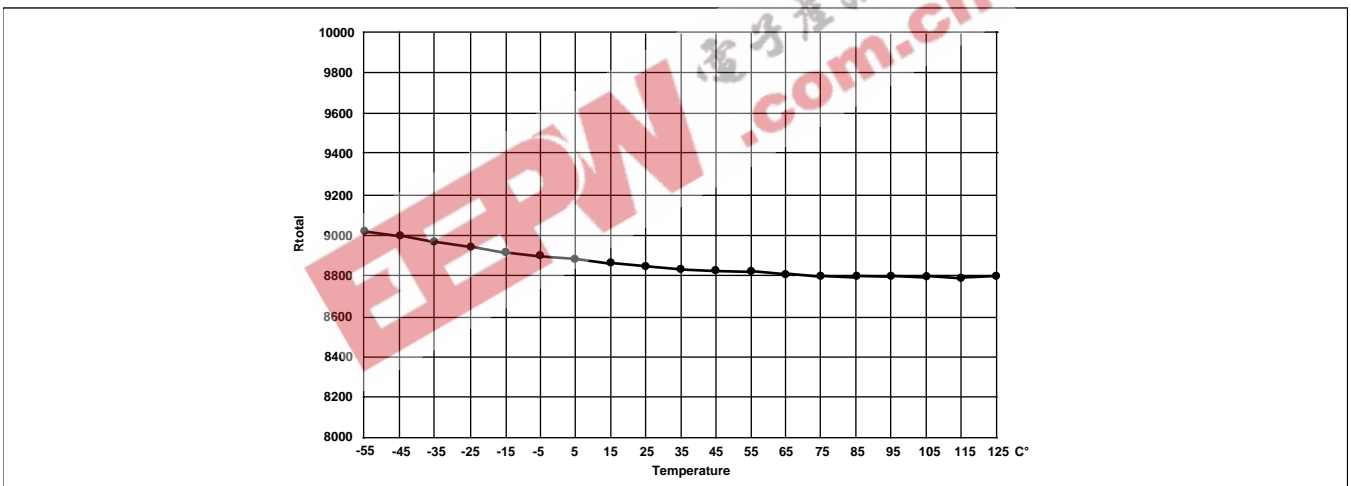

TYPICAL TOTAL RESISTANCE TEMPERATURE COEFFICIENT

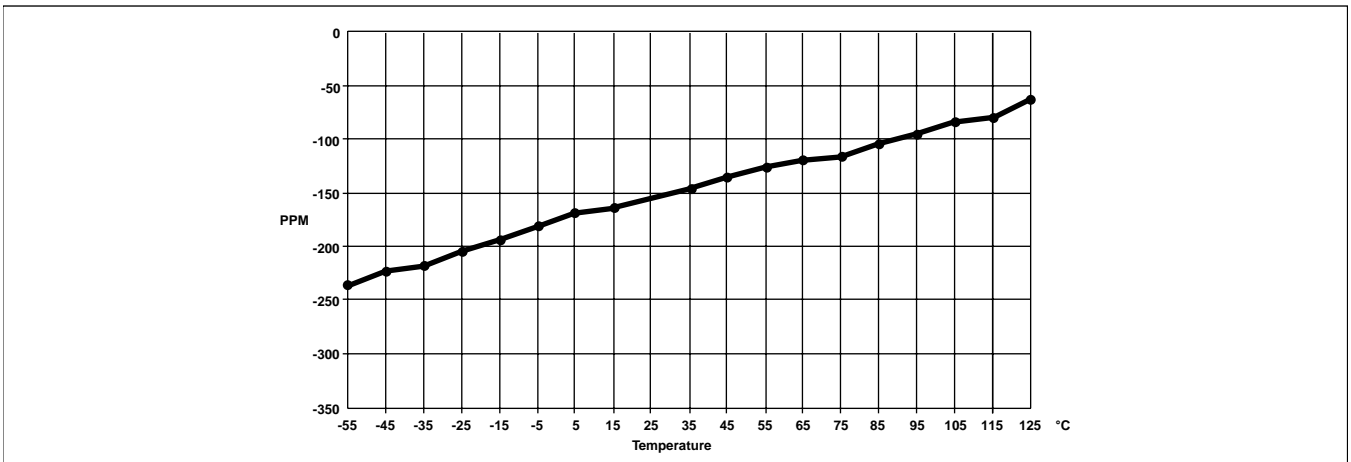

X9015

TYPICAL WIPER RESISTANCE

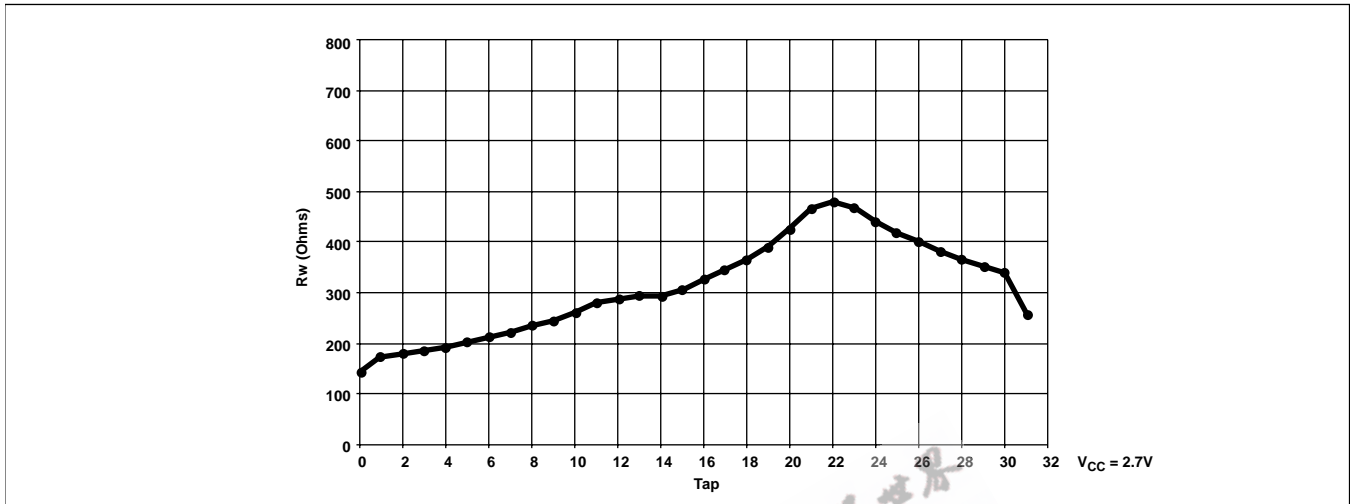

TYPICAL ABSOLUTE % ERROR PER TAP POSITION

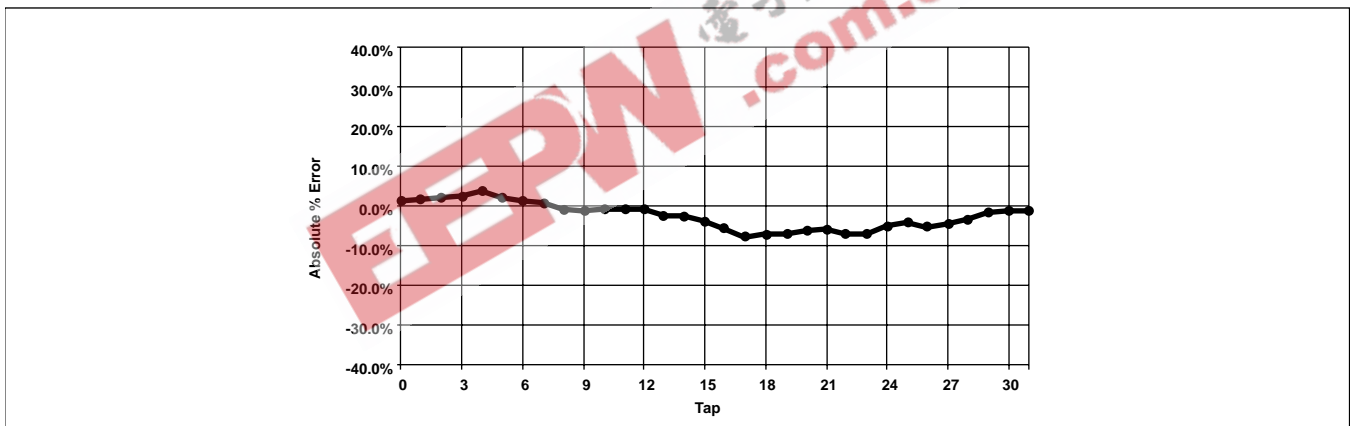

TYPICAL RELATIVE % ERROR PER TAP POSITION

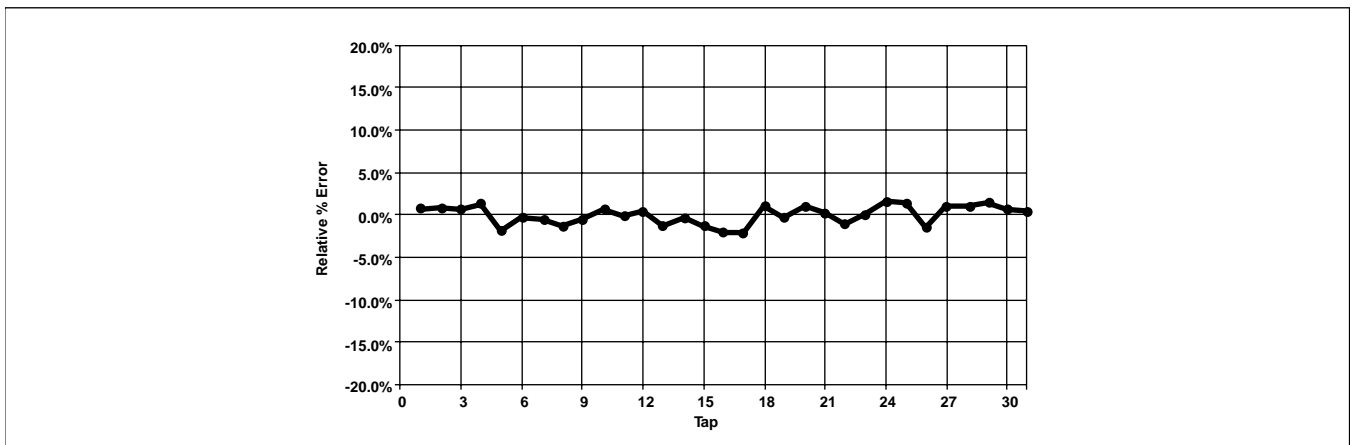

X9015

APPLICATIONS INFORMATION

Electronic digitally-controlled (XDCP) potentiometers provide two powerful application advantages; (1) the variability and reliability of a solid-state potentiometer, and (2) the flexibility of computer-based digital controls.

Basic Configurations of Electronic Potentiometers

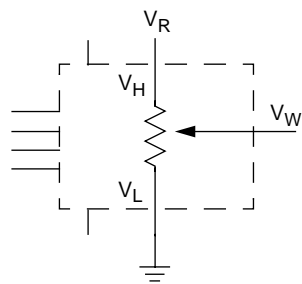

Three terminal potentiometer; variable voltage divider

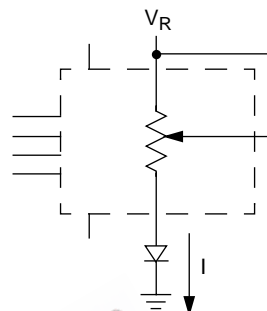

Two terminal variable resistor; variable current

Basic Circuits

Buffered Reference Voltage

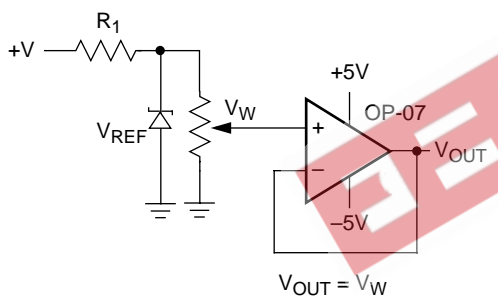

$$V_{OUT} = V_W$$

Cascading Techniques

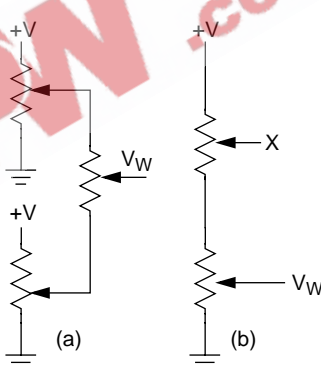

(a)

(b)

Noninverting Amplifier

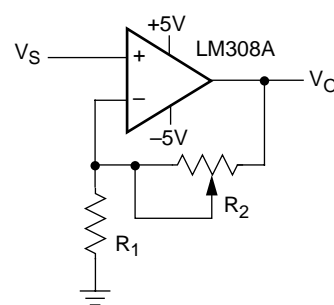

$$V_O = (1 + R_2/R_1)V_S$$

Voltage Regulator

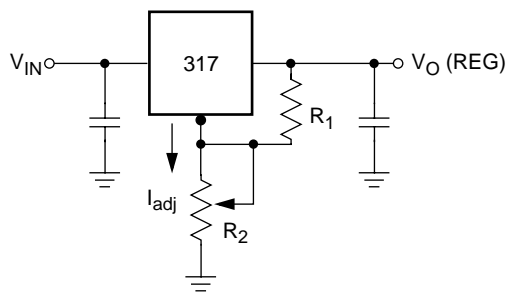

$$V_O (REG) = 1.25V (1 + R_2/R_1) + I_{adj} R_2$$

Offset Voltage Adjustment

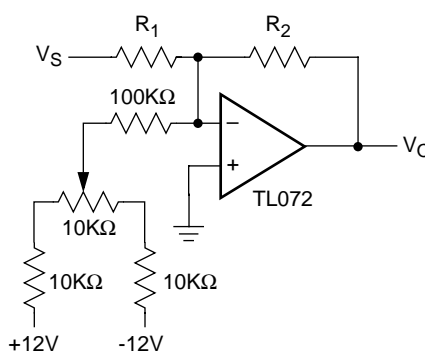

Comparator with Hysteresis

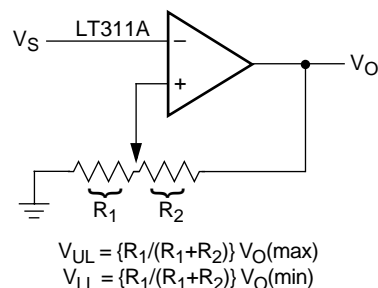

$$V_{UL} = \{R_1/(R_1 + R_2)\} V_O(max)$$

$$V_{LL} = \{R_1/(R_1 + R_2)\} V_O(min)$$

(for additional circuits see AN115)

X9015

SOIC PACKAGING INFORMATION

8-LEAD PLASTIC SMALL OUTLINE GULL WING PACKAGE TYPE S

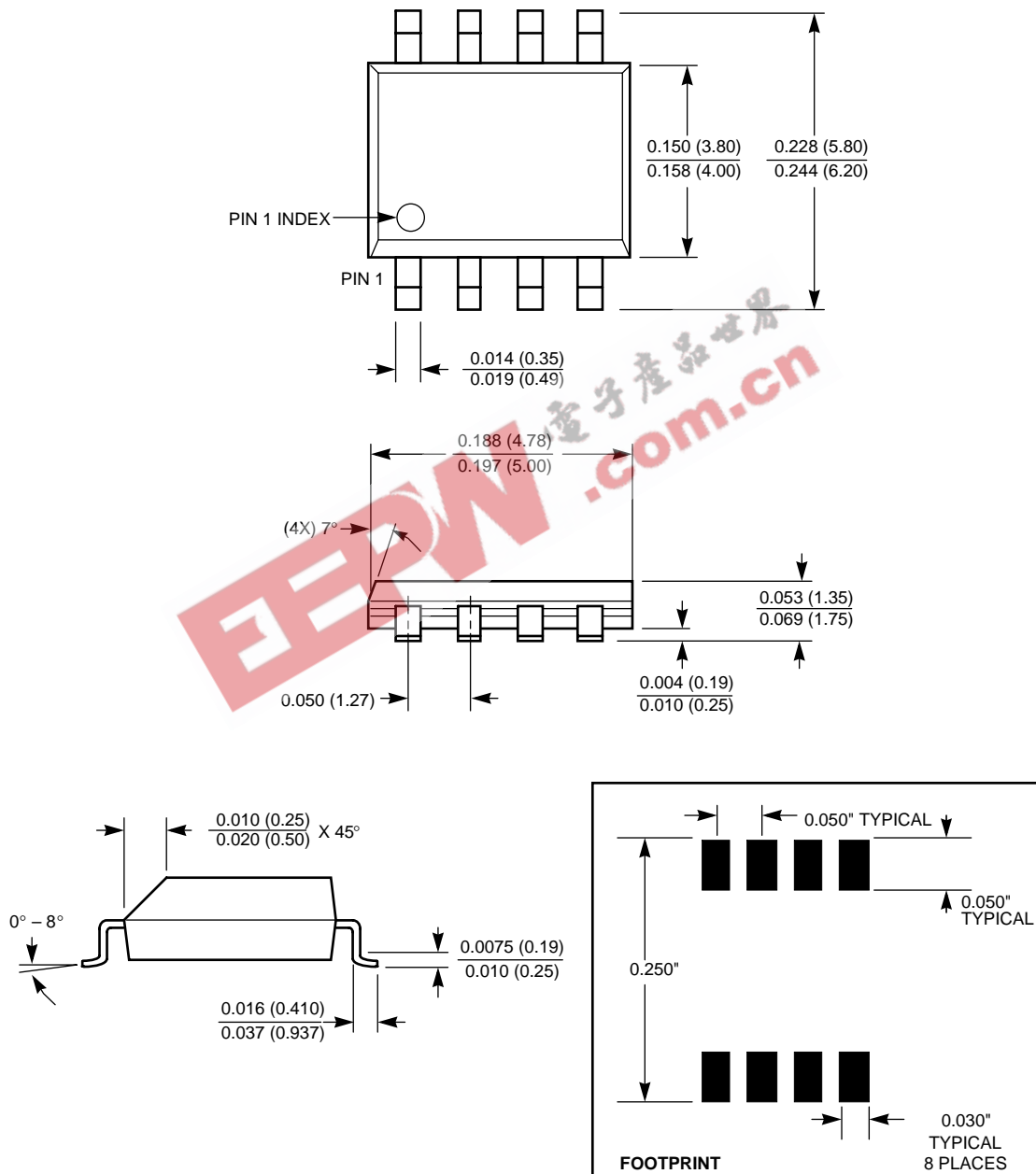

NOTE: ALL DIMENSIONS IN INCHES (IN PARENTHESES IN MILLIMETERS)

X9015

ORDERING INFORMATION

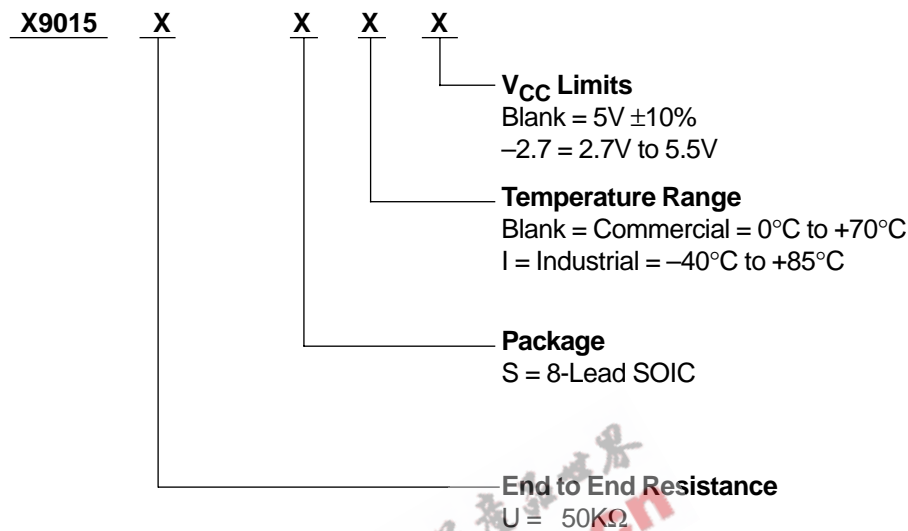

Physical Characteristics

Marking Includes

- Manufacturer's Trademark
- Resistance Value or Code
- Date Code

LIMITED WARRANTY

Devices sold by Xicor, Inc. are covered by the warranty and patent indemnification provisions appearing in its Terms of Sale only. Xicor, Inc. makes no warranty, express, statutory, implied, or by description regarding the information set forth herein or regarding the freedom of the described devices from patent infringement. Xicor, Inc. makes no warranty of merchantability or fitness for any purpose. Xicor, Inc. reserves the right to discontinue production and change specifications and prices at any time and without notice.

Xicor, Inc. assumes no responsibility for the use of any circuitry other than circuitry embodied in a Xicor, Inc. product. No other circuits, patents, licenses are implied.

U.S. PATENTS

Xicor products are covered by one or more of the following U.S. Patents: 4,263,664; 4,274,012; 4,300,212; 4,314,265; 4,326,134; 4,393,481; 4,404,475; 4,450,402; 4,486,769; 4,488,060; 4,520,461; 4,533,846; 4,599,706; 4,617,652; 4,668,932; 4,752,912; 4,829, 482; 4,874, 967; 4,883, 976. Foreign patents and additional patents pending.

LIFE RELATED POLICY

In situations where semiconductor component failure may endanger life, system designers using this product should design the system with appropriate error detection and correction, redundancy and back-up features to prevent such an occurrence.

Xicor's products are not authorized for use in critical components in life support devices or systems.

1. Life support devices or systems are devices or systems which, (a) are intended for surgical implant into the body, or (b) support or sustain life, and whose failure to perform, when properly used in accordance with instructions for use provided in the labeling, can be reasonably expected to result in a significant injury to the user.
2. A critical component is any component of a life support device or system whose failure to perform can be reasonably expected to cause the failure of the life support device or system, or to affect its safety or effectiveness.