

Single Digitally-Controlled (XDCP™) Potentiometer

The X9110 integrates a single digitally controlled potentiometer (XDCP) on a monolithic CMOS integrated circuit.

The digital controlled potentiometer is implemented using 1023 resistive elements in a series array. Between each element are tap points connected to the wiper terminal through switches. The position of the wiper on the array is controlled by the user through the SPI bus interface. The potentiometer has associated with it a volatile Wiper Counter Register (WCR) and four non-volatile Data Registers that can be directly written to and read by the user. The contents of the WCR controls the position of the wiper on the resistor array through the switches. Power-up recalls the contents of the default data register (DR0) to the WCR.

The XDCP can be used as a three-terminal potentiometer or as a two terminal variable resistor in a wide variety of applications including control, parameter adjustments, and signal processing.

Features

- 1024 Resistor Taps – 10-Bit Resolution
- SPI Serial Interface for write, read, and transfer operations of the potentiometer
- Wiper Resistance, 40Ω Typical @ 5V
- Four Non-Volatile Data Registers
- Non-Volatile Storage of Multiple Wiper Positions
- Power-on Recall. Loads Saved Wiper Position on Power-up
- Standby Current < 3μA Max
- System V_{CC}: 2.7V to 5.5V Operation
- Analog V₊/V₋: -5V to +5V
- 100kΩ End to End Resistance
- 100 yr. Data Retention
- Endurance: 100, 000 Data Changes Per Bit Per Register
- 14 Ld TSSOP
- Dual Supply Version of the X9111
- Low Power CMOS
- Pb-Free Plus Anneal Available (RoHS Compliant)

Pinout

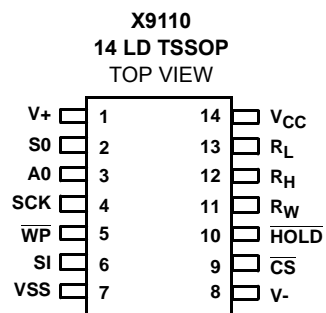

Functional Diagram

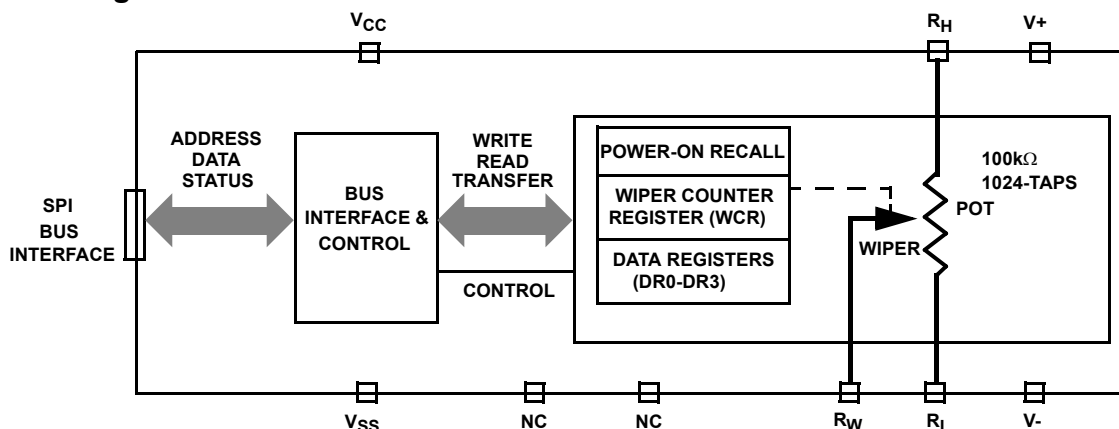

X9110

Ordering Information

PART NUMBER	PART MARKING	VCC LIMITS (V)	POTENTIOMETER RANGE (k Ω)	TEMP RANGE ($^{\circ}$ C)	PACKAGE
X9110TV14	X9110TV	5 \pm 10	100	0 to 70	14 Ld TSSOP
X9110TV14Z (Note)	X9110TV Z			0 to 70	14 Ld TSSOP (Pb-free)
X9110TV14I	X9110TV I			-40 to 85	14 Ld TSSOP
X9110TV14IZ (Note)	X9110TV Z I			-40 to 85	14 Ld TSSOP (Pb-free)
X9110TV14-2.7	X9110TV F	2.7 to 5.5		0 to 70	14 Ld TSSOP
X9110TV14Z-2.7 (Note)	X9110TV Z F			0 to 70	14 Ld TSSOP (Pb-free)
X9110TV14I-2.7	X9110TV G			-40 to 85	14 Ld TSSOP
X9110TV14IZ-2.7 (Note)	X9110TV Z G			-40 to 85	14 Ld TSSOP (Pb-free)

NOTE: Intersil Pb-free plus anneal products employ special Pb-free material sets; molding compounds/die attach materials and 100% matte tin plate termination finish, which are RoHS compliant and compatible with both SnPb and Pb-free soldering operations. Intersil Pb-free products are MSL classified at Pb-free peak reflow temperatures that meet or exceed the Pb-free requirements of IPC/JEDEC J STD-020.

Detailed Functional Diagram

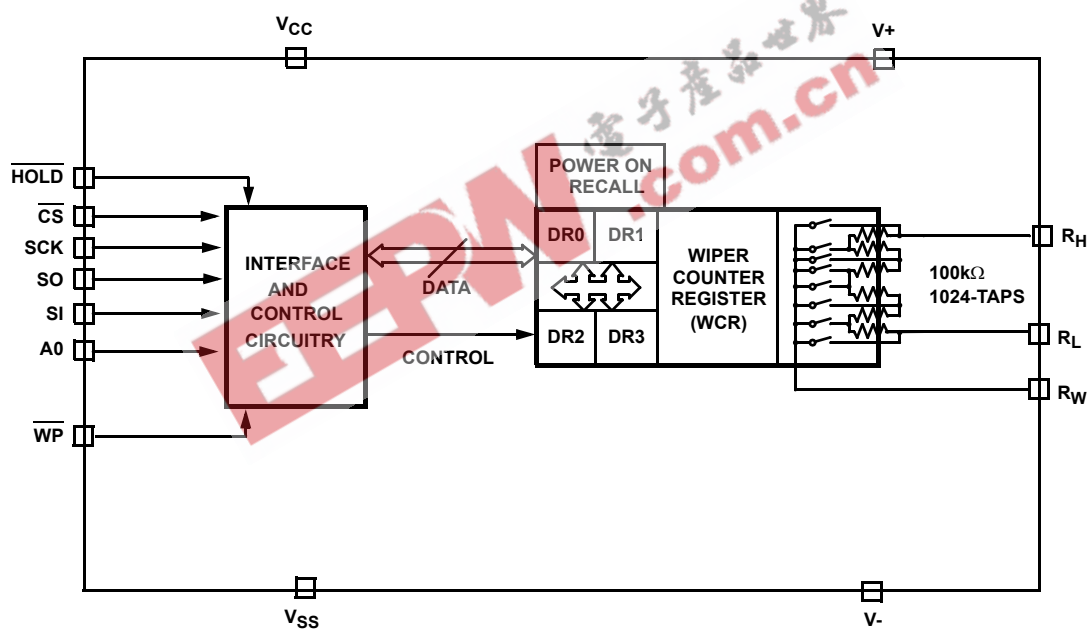

Circuit Level Applications

- Vary the gain of a voltage amplifier
- Provide programmable dc reference voltages for comparators and detectors
- Control the volume in audio circuits
- Trim out the offset voltage error in a voltage amplifier circuit
- Set the output voltage of a voltage regulator
- Trim the resistance in Wheatstone bridge circuits
- Control the gain, characteristic frequency and Q-factor in filter circuits
- Set the scale factor and zero point in sensor signal conditioning circuits
- Vary the frequency and duty cycle of timer ICs
- Vary the dc biasing of a pin diode attenuator in RF circuits
- Provide a control variable (I, V, or R) in feedback circuits

System Level Applications

- Adjust the contrast in LCD displays
- Control the power level of LED transmitters in communication systems
- Set and regulate the DC biasing point in an RF power amplifier in wireless systems
- Control the gain in audio and home entertainment systems
- Provide the variable DC bias for tuners in RF wireless systems
- Set the operating points in temperature control systems
- Control the operating point for sensors in industrial systems
- Trim offset and gain errors in artificial intelligent systems

Pin Descriptions

PIN (TSSOP)	SYMBOL	FUNCTION
1	V+	Analog Supply Voltage
2	SO	Serial Data Output
3	A0	Device Address
4	SCK	Serial Clock
5	\overline{WP}	Hardware Write Protect
6	SI	Serial Data Input
7	V _{SS}	System Ground
8	V-	Analog Supply Voltage
9	CS	Chip Select
10	\overline{HOLD}	Device Select. Pause the Serial Bus

Pin Descriptions

PIN (TSSOP)	SYMBOL	FUNCTION
11	R _W	Wiper Terminal of the Potentiometer
12	R _H	High Terminal of the Potentiometer
13	R _L	Low Terminal of the Potentiometer
14	V _{CC}	System Supply Voltage

Bus Interface Pins

SERIAL OUTPUT (SO)

SO is a serial data output pin. During a read cycle, data is shifted out on this pin. Data is clocked out on the falling edge of the serial clock.

SERIAL INPUT (SI)

SI is the serial data input pin. All opcodes, byte addresses and data to be written to the pots and pot registers are input on this pin. Data is latched by the rising edge of the serial clock.

SERIAL CLOCK (SCK)

The SCK input is used to clock data into and out of the X9110.

HOLD (\overline{HOLD})

\overline{HOLD} is used in conjunction with the \overline{CS} pin to select the device. Once the part is selected and a serial sequence is underway, \overline{HOLD} may be used to pause the serial communication with the controller without resetting the serial sequence. To pause, \overline{HOLD} must be brought LOW while SCK is LOW. To resume communication, \overline{HOLD} is brought HIGH, again while SCK is LOW. If the pause feature is not used, \overline{HOLD} should be held HIGH at all times.

DEVICE ADDRESS (A0)

The address input is used to set the 8-bit slave address. A match in the slave address serial data stream A0 must be made with the address input (A0) in order to initiate communication with the X9110.

CHIP SELECT (\overline{CS})

When \overline{CS} is HIGH, the X9110 is deselected and the SO pin is at high impedance, and (unless an internal write cycle is underway) the device will be in the standby state. \overline{CS} LOW enables the X9110, placing it in the active power mode. It should be noted that after a power-up, a HIGH to LOW transition on \overline{CS} is required prior to the start of any operation.

HARDWARE WRITE PROTECT INPUT (\overline{WP})

The \overline{WP} pin when LOW prevents nonvolatile writes to the Data Registers.

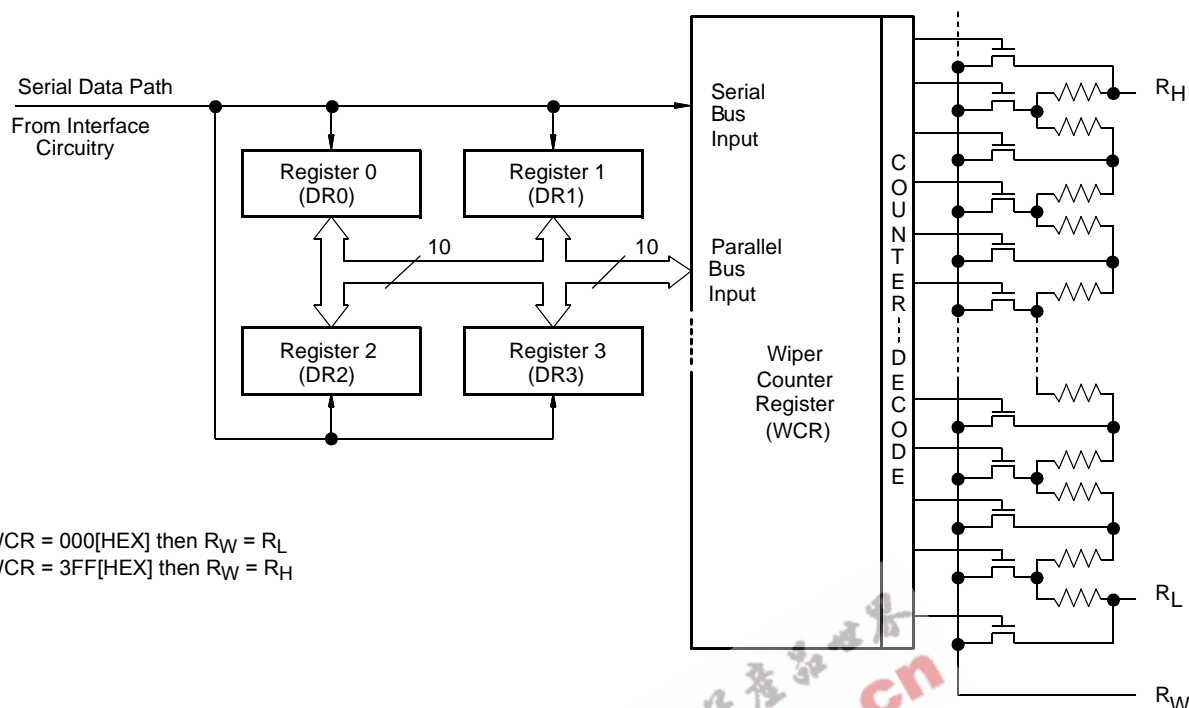

FIGURE 1. DETAILED POTENTIOMETER BLOCK DIAGRAM

Potentiometer Pins

R_H , R_L

The R_H and R_L pins are equivalent to the terminal connections on a mechanical potentiometer.

R_W

The wiper pin are equivalent to the wiper terminal of a mechanical potentiometer.

Bias Supply Pins

SYSTEM SUPPLY VOLTAGE (V_{CC}) AND SUPPLY GROUND (V_{SS})

The V_{CC} pin is the system supply voltage. The V_{SS} pin is the system ground.

ANALOG SUPPLY VOLTAGES ($V+$ AND $V-$)

These supplies are the analog voltage supplies for the potentiometer. The $V+$ supply is tied to the wiper switches while the $V-$ supply is used to bias the switches and the internal P+ substrate of the integrated circuit. Both of these supplies set the voltage limits of the potentiometer.

Principles Of Operation

Device Description

SERIAL INTERFACE

The X9110 supports the SPI interface hardware conventions. The device is accessed via the SI input with data clocked-in

on the rising SCK. \overline{CS} must be LOW and the \overline{HOLD} and \overline{WP} pins must be HIGH during the entire operation.

The SO and SI pins can be connected together, since they have three state outputs. This can help to reduce system pin count.

ARRAY DESCRIPTION

The X9110 is comprised of a resistor array (Figure 1). The array contains the equivalent of 1023 discrete resistive segments that are connected in series. The physical ends of each array are equivalent to the fixed terminals of a mechanical potentiometer (R_H and R_L inputs).

At both ends of each array and between each resistor segment is a CMOS switch connected to the wiper (R_W) output. Within the individual array only one switch may be turned on at a time.

These switches are controlled by a Wiper Counter Register (WCR). The 10-bits of the WCR (WCR[9:0]) are decoded to select, and enable, one of 1024 switches.

WIPER COUNTER REGISTER (WCR)

The X9110 contains a Wiper Counter Register (See Table 1) for the XDCP potentiometer. The WCR is equivalent to a serial-in, parallel-out register/counter with its outputs decoded to select one of 1024 switches along its resistor array. The contents of the WCR can be altered in one of three ways: (1) it may be written directly by the host via the write Wiper Counter Register instruction (serial load); (2) it

X9110

may be written indirectly by transferring the contents of one of four associated Data Registers via the XFR Data Register; (3) it is loaded with the contents of its data register zero (DR0) upon power-up.

The Wiper Counter Register is a volatile register; that is, its contents are lost when the X9110 is powered-down. Although the register is automatically loaded with the value in DR0 upon power-up, this may be different from the value present at power-down. Power-up guidelines are recommended to ensure proper loadings of the DR0 value into the WCR.

DATA REGISTERS (DR)

The potentiometer has four 10-bit non-volatile Data Registers. These can be read or written directly by the host. Data can also be transferred between any of the four Data Registers and the Wiper Counter Register. All operations changing data in one of the Data Registers is a nonvolatile operation and will take a maximum of 10ms.

If the application does not require storage of multiple settings for the potentiometer, the Data Registers can be used as regular memory locations for system parameters or user preference data.

DR[9:0] is used to store one of the 1024 wiper position (0 ~1023). Table 2.

STATUS REGISTER (SR)

This 1-bit status register is used to store the system status (see Table 3).

WIP: Write In Progress status bit, read only.

- When WIP=1, indicates that high-voltage write cycle is in progress.
- When WIP=0, indicates that no high-voltage write cycle is in progress.

TABLE 1. WIPER CONTROL REGISTER, WCR (10-BIT), WCR9–WCR0: Used To Store The Current Wiper Position (Volatile, V)

WCR9	WCR8	WCR7	WCR6	WCR5	WCR4	WCR3	WCR2	WCR1	WCR0
V	V	V	V	V	V	V	V	V	V
(MSB)									(LSB)

TABLE 2. DATA REGISTER, DR (10-BIT), BIT 9–BIT 0: Used to store wiper positions or data (Non-Volatile, NV)

BIT 9	BIT 8	BIT 7	BIT 6	BIT 5	BIT 4	BIT 3	BIT 2	BIT 1	BIT 0
NV	NV	NV	NV	NV	NV	NV	NV	NV	NV
MSB									LSB

TABLE 3. STATUS REGISTER, SR (1-BIT)

WIP
(LSB)

TABLE 4. IDENTIFICATION BYTE FORMAT

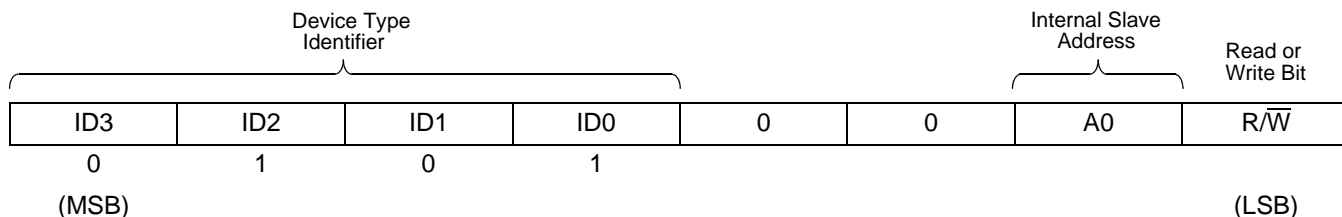
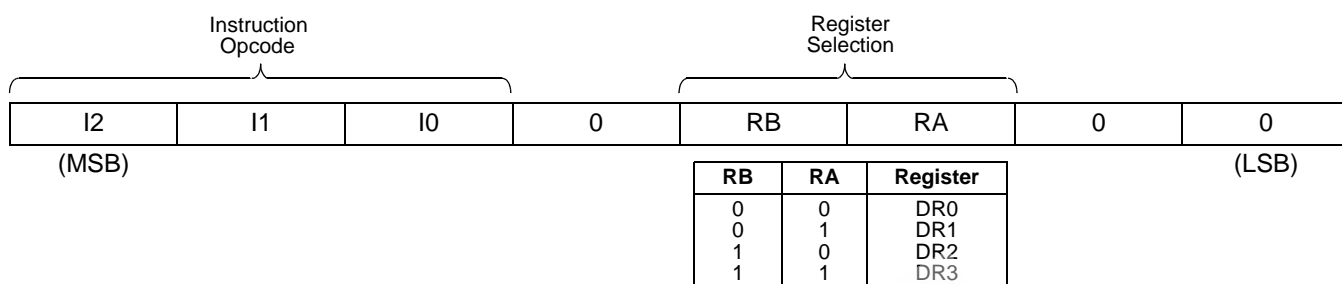

TABLE 5. INSTRUCTION BYTE FORMAT



Device Instructions

Identification Byte (ID and A)

The first byte sent to the X9110 from the host, following a \overline{CS} going HIGH to LOW, is called the Identification Byte. The most significant four bits of the slave address are a device type identifier. The ID[3:0] bits is the device ID for the X9110; this is fixed as 0101[B] (refer to Table 4).

The A0 bit in the ID byte is the internal slave address. The physical device address is defined by the state of the A0 input pin. The slave address is externally specified by the user. The X9110 compares the serial data stream with the address input state; a successful compare of the address bit is required for the X9110 to successfully continue the command sequence. Only the device whose slave address matches the incoming device address sent by the master executes the instruction. The A0 input can be actively driven by CMOS input signals or tied to V_{CC} or V_{SS} . The R/W bit is used to set the device to either read or write mode.

Instruction Byte and Register Selection

The next byte sent to the X9110 contains the instruction and register pointer information. The three most significant bits are used provide the instruction opcode (I[2:0]). The RB and RA bits point to one of the four registers. The format is shown in Table 5.

Data Registers or directly between the host and the Wiper Counter Register. These instructions are:

- **XFR Data Register to Wiper Counter Register** – This transfers the contents of one specified Data Register to

Five of the seven instructions are four bytes in length. These instructions are:

- **Read Wiper Counter Register** – read the current wiper position of the selected pot,
- **Write Wiper Counter Register** – change current wiper position of the selected pot,
- **Read Data Register** – read the contents of the selected data register;
- **Write Data Register** – write a new value to the selected data register.
- **Read Status** – This command returns the contents of the WIP bit which indicates if the internal write cycle is in progress.

The basic sequence of the four byte instructions is illustrated in Figure 3. These four-byte instructions exchange data between the WCR and one of the Data Registers. A transfer from a Data Register to a WCR is essentially a write to a static RAM, with the static RAM controlling the wiper position. The response of the wiper to this action will be delayed by t_{WRL} . A transfer from the WCR (current wiper position), to a Data Register is a write to nonvolatile memory and takes a minimum of t_{WR} to complete. The transfer can occur between the potentiometer and one of its associated registers. The Read Status Register instruction is the only unique format (see Figure 4).

Two instructions require a two-byte sequence to complete (See Figure 2). These instructions transfer data between the host and the X9110; either between the host and one of the

the associated Wiper Counter Register.

- **XFR Wiper Counter Register to Data Register** – This transfers the contents of the specified Wiper Counter Register to the specified associated Data Register.

See Instruction format for more details.

Write in Process (WIP bit)

The contents of the Data Registers are saved to nonvolatile memory when the \overline{CS} pin goes from LOW to HIGH after a complete write sequence is received by the device. The progress of this internal write operation can be monitored by a Write In Process bit (WIP). The WIP bit is read with a Read Status command (See Figure 4).

Power-up and Down Requirements

At all times, the V+ voltage must be greater than or equal to the voltage at R_H or R_L, and the voltage at R_H or R_L must be greater than or equal to the voltage at V-. During power-up and power-down, V_{CC}, V+, and V- must reach their final values within 1msec of each other.

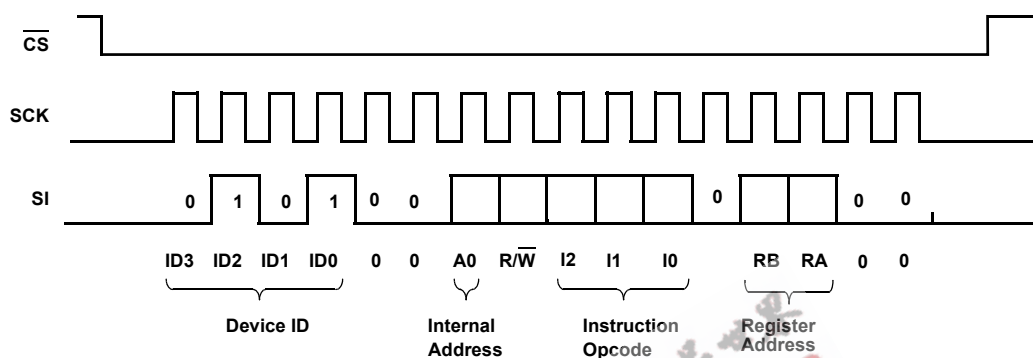

FIGURE 2. TWO-BYTE INSTRUCTION SEQUENCE

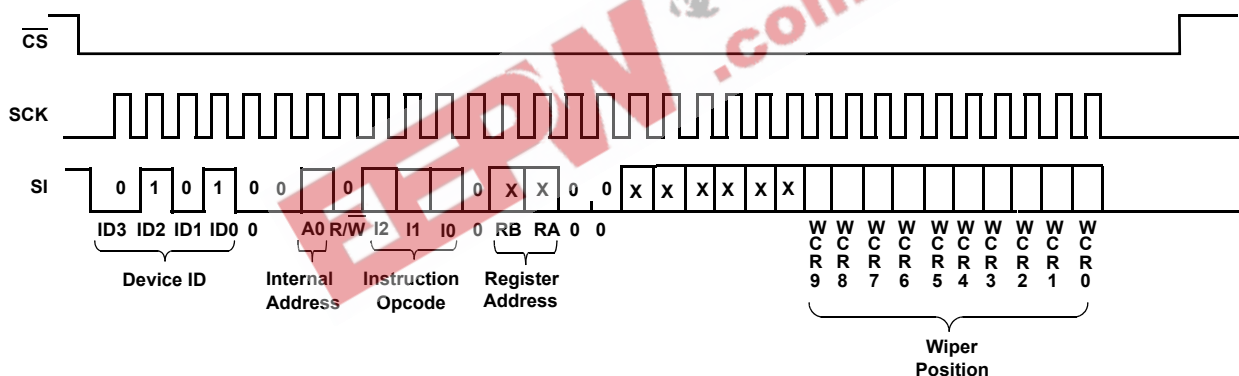

FIGURE 3. FOUR-BYTE INSTRUCTION SEQUENCE (WRITE OR READ FOR WCR OR DATA REGISTERS)

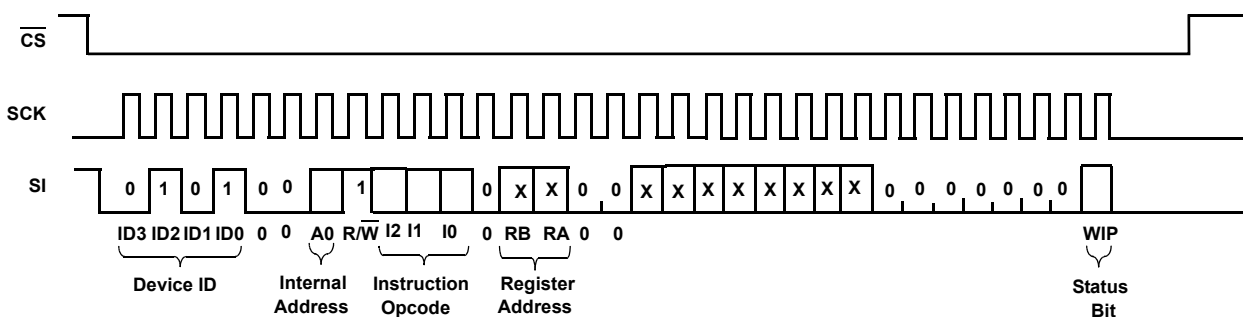

FIGURE 4. FOUR-BYTE INSTRUCTION SEQUENCE (READ STATUS REGISTERS)

X9110

TABLE 6. INSTRUCTION SET

INSTRUCTION	INSTRUCTION SET									OPERATION	
	R/W	I ₂	I ₁	I ₀	0	RB	RA	0	0		
Read Wiper Counter Register	1	1	0	0	0	0	0	0	0	0	Read the contents of the Wiper Counter Register
Write Wiper Counter Register	0	1	0	1	0	0	0	0	0	0	Write new value to the Wiper Counter Register
Read Data Register	1	1	0	1	0	1/0	1/0	0	0	0	Read the contents of the Data Register pointed to RB-RA
Write Data Register	0	1	1	0	0	1/0	1/0	0	0	0	Write new value to the Data Register pointed to RB-RA
XFR Data Register to Wiper Counter Register	1	1	1	0	0	1/0	1/0	0	0	0	Transfer the contents of the Data Register pointed to by RB-RA to the Wiper Counter Register
XFR Wiper Counter Register to Data Register	0	1	1	1	0	1/0	1/0	0	0	0	Transfer the contents of the Wiper Counter Register to the Data Register pointed to by RB-RA
Read Status (WIP bit)	1	0	1	0	0	0	0	0	0	1	Read the status of the internal write cycle, by checking the WIP bit (read status register).

NOTE: 1/0 = data is one or zero

Instruction Format

Read Wiper Counter Register (WCR)

$\overline{\text{CS}}$ Falling Edge	Device Type Identifier		Device Addresses		R/W = 1	Instruction Opcode				Register Addresses				Wiper Position (Sent by X9110 on SO)						$\overline{\text{CS}}$ Rising Edge													
	0	1	0	1		0	0	0	A0	1	0	0	0	0	0	0	0	0	X		X	X	X	X	X	WCR9	WCR8	WCR7	WCR6	WCR5	WCR4	WCR3	WCR2
	0	1	0	1	0	0	0	A0	1	0	0	0	0	0	0	0	0	X	X	X	X	X	X	WCR9	WCR8	WCR7	WCR6	WCR5	WCR4	WCR3	WCR2	WCR1	WCR0

Write Wiper Counter Register (WCR)

$\overline{\text{CS}}$ Falling Edge	Device Type Identifier		Device Addresses		R/W = 0	Instruction Opcode				Register Addresses				Wiper Position (Sent by Master on SI)						$\overline{\text{CS}}$ Rising Edge													
	0	1	0	1		0	0	0	A0	1	0	1	0	0	0	0	0	0	X		X	X	X	X	X	WCR9	WCR8	WCR7	WCR6	WCR5	WCR4	WCR3	WCR2
	0	1	0	1	0	0	0	A0	1	0	1	0	0	0	0	0	0	X	X	X	X	X	X	WCR9	WCR8	WCR7	WCR6	WCR5	WCR4	WCR3	WCR2	WCR1	WCR0

Read Data Register (DR)

$\overline{\text{CS}}$ Falling Edge	Device Type Identifier		Device Addresses		R/W = 1	Instruction Opcode				Register Addresses				Wiper Position (Sent by X9110 on SO)						$\overline{\text{CS}}$ Rising Edge												
	0	1	0	1		0	0	0	A0	1	0	1	0	RB	RA	0	0	X	X		X	X	X	X	WCR9	WCR8	WCR7	WCR6	WCR5	WCR4	WCR3	WCR2
	0	1	0	1	0	0	0	A0	1	0	1	0	RB	RA	0	0	X	X	X	X	X	X	WCR9	WCR8	WCR7	WCR6	WCR5	WCR4	WCR3	WCR2	WCR1	WCR0

X9110

Write Data Register (DR)

$\overline{\text{CS}}$ Falling Edge	Device Type Identifier				Device Addresses				Instruction Opcode				Register Address				Wiper Position or Data (Sent by Master on SI)				Wiper Position or Data (Sent by Master on SI)				$\overline{\text{CS}}$ Rising Edge	HIGH-VOLTAGE WRITE CYCLE										
	0	1	0	1	0	0	A0	R/W = 0	1	1	0	0	RB	RA	0	0	X	X	X	X	X	X	X	X			WCR 9	WCR 8	WCR 7	WCR 6	WCR 5	WCR 4	WCR 3	WCR 2	WCR 1	WCR 0
	0	1	0	1	0	0	A0	R/W = 0	1	1	0	0	RB	RA	0	0	X	X	X	X	X	X	X	X	WCR 9	WCR 8	WCR 7	WCR 6	WCR 5	WCR 4	WCR 3	WCR 2	WCR 1	WCR 0		

Transfer Data Register (DR) to Wiper Counter Register (WCR)

$\overline{\text{CS}}$ Falling Edge	Device Type Identifier				Device Addresses				Instruction Opcode				Register Address				$\overline{\text{CS}}$ Rising Edge
	0	1	0	1	0	0	A0	R/W = 1	1	1	0	0	RB	RA	0	0	
	0	1	0	1	0	0	A0	R/W = 1	1	1	0	0	RB	RA	0	0	

Transfer Wiper Counter Register (WCR) to Data Register (DR)

$\overline{\text{CS}}$ Falling Edge	Device Type Identifier				Device Addresses				Instruction Opcode				Register Address				$\overline{\text{CS}}$ Rising Edge	HIGH-VOLTAGE WRITE CYCLE
	0	1	0	1	0	0	A0	R/W = 0	1	1	1	0	RB	RA	0	0		
	0	1	0	1	0	0	A0	R/W = 0	1	1	1	0	RB	RA	0	0		

Read Status Register (SR)

$\overline{\text{CS}}$ Falling Edge	Device Type Identifier				Device Addresses				Instruction Opcode				Register Addresses				Status Data (Sent by Slave on SO)				Status Data (Sent by Slave on SO)				$\overline{\text{CS}}$ Rising Edge									
	0	1	0	1	0	0	A0	R/W = 1	0	1	0	X	0	0	0	1	X	X	X	X	X	X	X	X		0	0	0	0	0	0	0	0	WIP
	0	1	0	1	0	0	A0	R/W = 1	0	1	0	X	0	0	0	1	X	X	X	X	X	X	X	X	0	0	0	0	0	0	0	0	WIP	

NOTES:

1. "A0": stands for the device address sent by the master.
2. WCRx refers to wiper position data in the Wiper Counter Register
3. "X": Don't Care.

X9110

Absolute Maximum Ratings

Temperature under bias	-65°C to +135°C
Storage temperature	-65°C to +150°C
Voltage on SCK any address input	
with respect to V _{SS}	-1V to +7V
Voltage on V+ (referenced to V _{SS}) (Note 4)	10V
Voltage on V- (referenced to V _{SS}) (Note 4)	-10V
(V+) - (V-)	12V
Any Voltage on R _H /R _L	V+
Any Voltage on R _L /R _H	V-
Lead temperature (soldering, 10s)	300°C
I _W (10 seconds)	±6mA

Recommended Operating Conditions

Temperature Range	
Commercial	0°C to +70°C
Industrial	-40°C to +85°C
Supply Voltage (V _{CC}) Limits (Note 4)	
X9110	5V ± 10%
X9110-2.7	2.7V to 5.5V

CAUTION: Stresses above those listed in "Absolute Maximum Ratings" may cause permanent damage to the device. This is a stress only rating and operation of the device at these or any other conditions above those indicated in the operational sections of this specification is not implied.

Analog Specifications Over recommended industrial (2.7V) operation conditions unless otherwise stated.

SYMBOL	PARAMETER	TEST CONDITIONS	MIN	TYP	MAX	UNITS
R _{TOTAL}	End to End Resistance			100		kΩ
	End to End Resistance Tolerance				±20	%
	Power Rating	25°C, each pot			50	mW
I _W	Wiper Current				±3	mA
R _W	Wiper Resistance	Wiper Current = ±3mA, V _{CC} = 3V		150	500	Ω
R _W	Wiper Resistance	I _W = ±3mA, V _{CC} = 5V			100	Ω
V _{v+}	Voltage on V+ pin	X9110 (Note 4)	+4.5		+5.5	V
		X9110-2.7 (Note 4)	+2.7		+5.5	
V _{v-}	Voltage on V- pin	X9110 (Note 4)	-5.5		-4.5	V
		X9110-2.7 (Note 4)	-5.5		-2.7	
V _{TERM}	Voltage on any R _H or R _L Pin	V _{SS} = 0V	V-		V+	V
	Noise	Ref: 1V		-120		dBV
	Resolution			0.1		%
	Absolute Linearity (Note 1)	R _{w(n)} (actual) - R _{w(n)} (expected), where n = 8 to 1006			±1	MI (Note 3)
		R _{w(n)} (actual) - R _{w(n)} (expected) (Note 5)			±1.5	MI (Note 3)
	Relative Linearity (Note 2)	R _{w(m+1)} - [R _{w(m)} + MI], where m = 8 to 1006			±0.5	MI (Note 3)
		R _{w(m+1)} - [R _{w(m)} + MI] (Note 5)			±1	MI (Note 3)
	Temperature Coefficient of R _{TOTAL}			±300		ppm/°C
	Ratiometric Temp. Coefficient				20	ppm/°C
C _H /C _L /C _W	Potentiometer Capacitances	See Macro model		10/10/25		pF

NOTES:

- Absolute linearity is utilized to determine actual wiper voltage versus expected voltage as determined by wiper position when used as a potentiometer.
- Relative linearity is utilized to determine the actual change in voltage between two successive tap positions when used as a potentiometer. It is a measure of the error in step size.
- MI = RTOT / 1023 or (R_H - R_L) / 1023, single pot
- V_{CC}, V+, V- must reach their final values within 1 msec of each other.
- n = 0, 1, 2, ..., 1023; m = 0, 1, 2, ..., 1022.

X9110

D.C. Operating Specifications *Over the recommended operating conditions unless otherwise specified.*

SYMBOL	PARAMETER	TEST CONDITIONS	MIN	TYP	MAX	UNITS
I _{CC1}	V _{CC} supply current (active)	f _{SCK} = 2.5 MHz, SO = Open, V _{CC} = 5.5V Other Inputs = V _{SS}			400	μA
I _{CC2}	V _{CC} supply current (nonvolatile write)	f _{SCK} = 2.5MHz, SO = Open, V _{CC} = 5.5V Other Inputs = V _{SS}		1	5	mA
I _{SB}	V _{CC} current (standby)	SCK = SI = V _{SS} , Addr. = V _{SS} , CS = V _{CC} = 5.5V			3	μA
I _{LI}	Input leakage current	V _{IN} = V _{SS} to V _{CC}			10	μA
I _{LO}	Output leakage current	V _{OUT} = V _{SS} to V _{CC}			10	μA
V _{IH}	Input HIGH voltage		V _{CC} × 0.7		V _{CC} + 1	V
V _{IL}	Input LOW voltage		-1		V _{CC} × 0.3	V
V _{OL}	Output LOW voltage	I _{OL} = 3mA			0.4	V
V _{OH}	Output HIGH voltage	I _{OH} = -1mA, V _{CC} ≥ +3V	V _{CC} - 0.8			V
V _{OH}	Output HIGH voltage	I _{OH} = -0.4mA, V _{CC} ≤ +3V	V _{CC} - 0.4			V

Endurance and Data Retention

PARAMETER	MIN	UNITS
Minimum Endurance	100,000	Data changes per bit per register
Data Retention	100	years

Capacitance

SYMBOL	TEST	TEST CONDITIONS	MAX	UNITS
C _{IN/OUT} (Notes 4,6)	Input/Output capacitance (SI)	V _{OUT} = 0V	8	pF
C _{OUT} (Note 6)	Output capacitance (SO)	V _{OUT} = 0V	8	pF
C _{IN} (Note 6)	Input capacitance (A0, CS, WP, HOLD, and SCK)	V _{IN} = 0V	6	pF

Power-up Timing

SYMBOL	PARAMETER	MIN	MAX	UNITS
t _r V _{CC} (Note 6)	V _{CC} Power-up Rate	0.2	50	V/ms
t _{PUR} (Note7)	Power-up to Initiation of read operation		1	ms
t _{PWW} (Note 7)	Power-up to Initiation of write operation		50	ms

NOTES:

6. This parameter is not 100% tested
7. t_{PUR} and t_{PWW} are the delays required from the time the (last) power supply (V_{CC}-) is stable until the specific instruction can be issued. These parameters are not 100% tested.
8. ESD Rating on RH, RL, RW pins is 1.5kV (HBM, 1.0μA leakage maximum), ESD rating on all other pins is 2.0kV.

A.C. Test Conditions

Input pulse levels	V _{CC} × 0.1 to V _{CC} × 0.9
Input rise and fall times	10ns
Input and output timing level	V _{CC} × 0.5

X9110

Equivalent A.C. Load Circuit

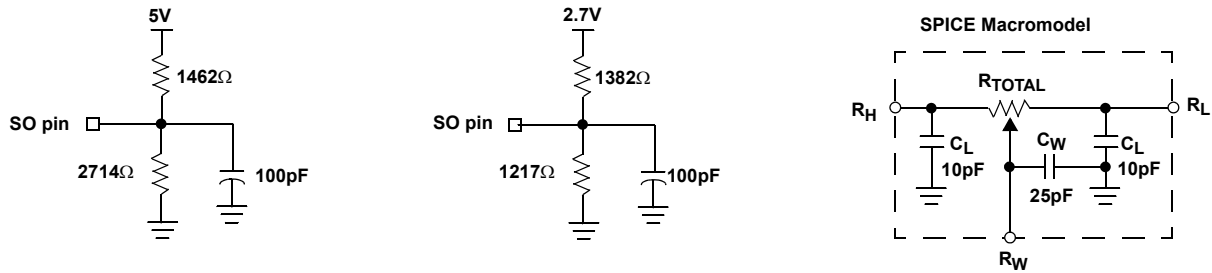

AC Timing

SYMBOL	PARAMETER	MIN	MAX	UNITS
f_{SCK}	SSI/SPI clock frequency		2.0	MHz
t_{CYC}	SSI/SPI clock cycle time	400		ns
t_{WH}	SSI/SPI clock high time	150		ns
t_{WL}	SSI/SPI clock low time	150		ns
t_{LEAD}	Lead time	150		ns
t_{LAG}	Lag time	150		ns
t_{SU}	SI, SCK, \overline{HOLD} and \overline{CS} input setup time	50		ns
t_H	SI, SCK, \overline{HOLD} and \overline{CS} input hold time	50		ns
t_{RI}	SI, SCK, \overline{HOLD} and \overline{CS} input rise time		50	ns
t_{FI}	SI, SCK, \overline{HOLD} and \overline{CS} input fall time		50	ns
t_{DIS}	SO output disable time	0	500	ns
t_V	SO output valid time		100	ns
t_{HO}	SO output hold time	0		ns
t_{RO}	SO output rise time		50	ns
t_{FO}	SO output fall time		50	ns
t_{HOLD}	\overline{HOLD} time	400		ns
t_{HSU}	\overline{HOLD} setup time	50		ns
t_{HH}	\overline{HOLD} hold time	50		ns
t_{HZ}	\overline{HOLD} low to output in high Z		100	ns
t_{LZ}	\overline{HOLD} high to output in low Z		100	ns
T_I	Noise suppression time constant at SI, SCK, \overline{HOLD} and \overline{CS} inputs		20	ns
t_{CS}	\overline{CS} deselect time	100		ns
t_{WPASU}	\overline{WP} , A0 setup time	0		ns
t_{WPAH}	\overline{WP} , A0 hold time	0		ns

X9110





High-Voltage Write Cycle Timing

SYMBOL	PARAMETER	TYP.	MAX.	UNITS
t_{WR}	High-voltage write cycle time (store instructions)	5	10	ms

XDCP Timing

SYMBOL	PARAMETER	MIN.	MAX.	UNITS
t_{WRPO}	Wiper response time after the third (last) power supply is stable	5	10	μ s
t_{WRL}	Wiper response time after instruction issued (all load instructions)	5	10	μ s

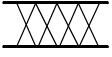
Symbol Table

WAVEFORM	INPUTS	OUTPUTS
	Must be steady	Will be steady
	May change from Low to High	Will change from Low to High
	May change from High to Low	Will change from High to Low
	Don't Care: Changes Allowed	Changing: State Not Known
	N/A	Center Line is High Impedance

EEPW.com.cn 电子產品世界

Timing Diagrams

Input Timing

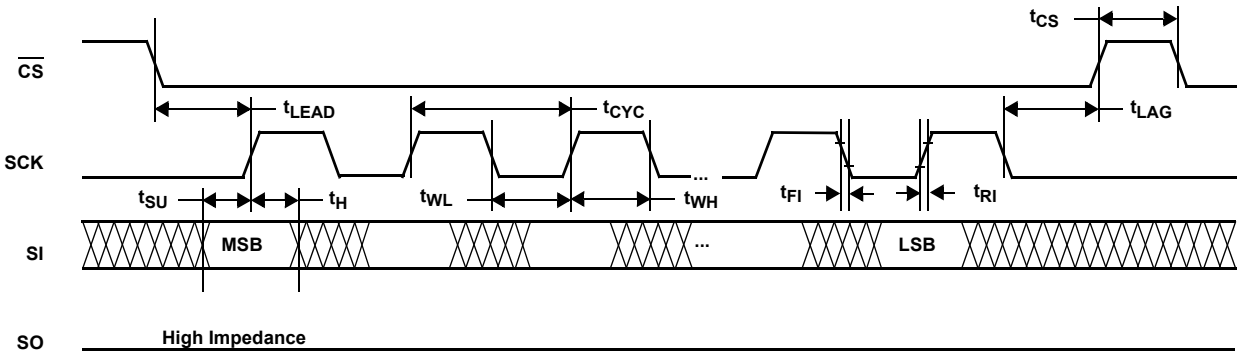

Output Timing

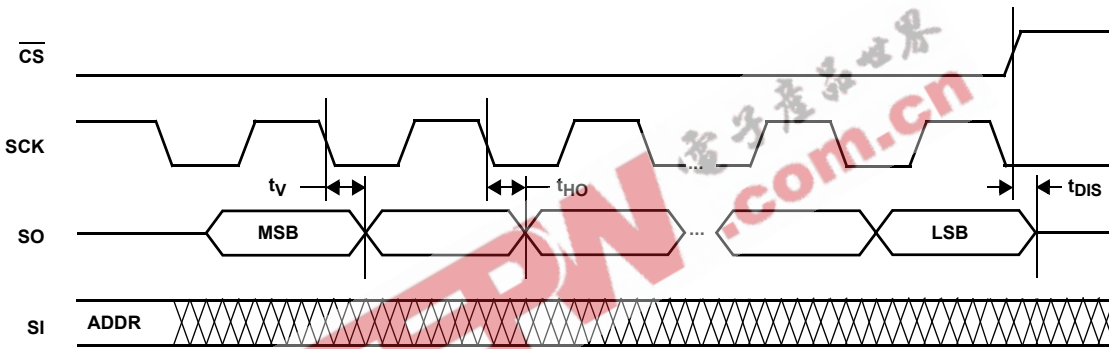

Hold Timing

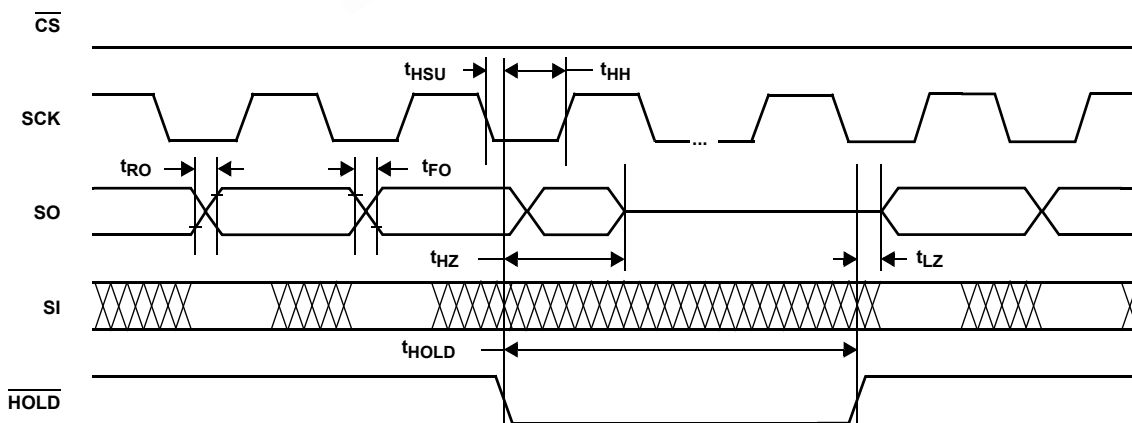

XDCP Timing (For All Load Instructions)

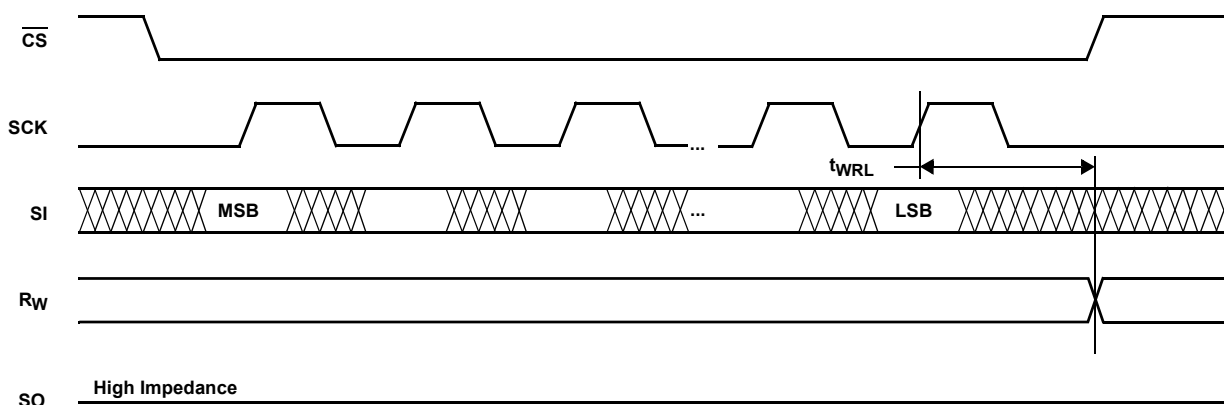

Write Protect And Device Address Pins Timing

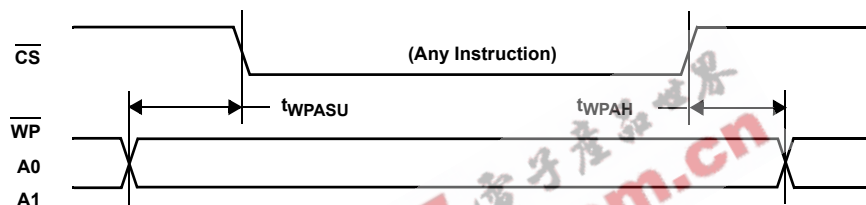

Applications information

Basic Configurations Of Electronic Potentiometers

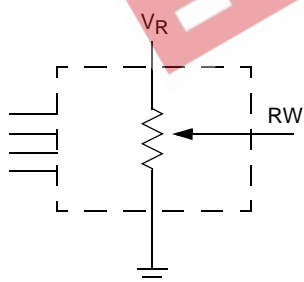

Three terminal Potentiometer;
Variable voltage divider

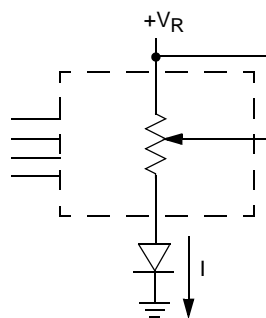

Two terminal Variable Resistor;
Variable current

Application Circuits

Noninverting Amplifier

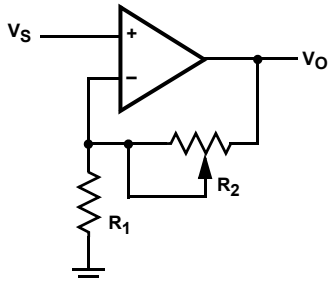

$$V_O = (1 + R_2/R_1)V_S$$

Voltage Regulator

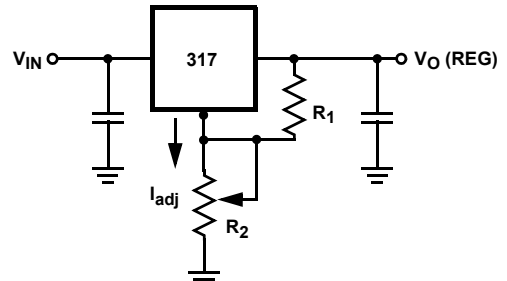

$$V_O (\text{REG}) = 1.25V (1 + R_2/R_1) + I_{adj} R_2$$

Offset Voltage Adjustment

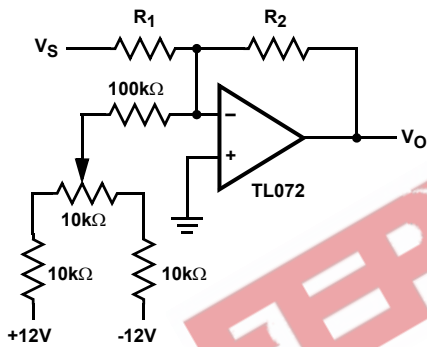

Comparator with Hysteresis

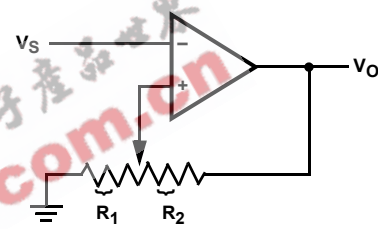

$$V_{UL} = \{R_1/(R_1+R_2)\} V_O(\text{max})$$

$$V_{LL} = \{R_1/(R_1+R_2)\} V_O(\text{min})$$

Application Circuits (continued)

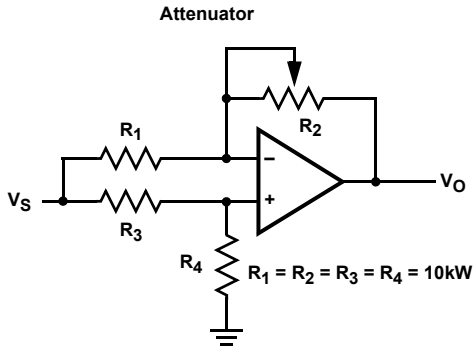

$$V_O = G V_S$$

$$-1/2 \leq G \leq +1/2$$

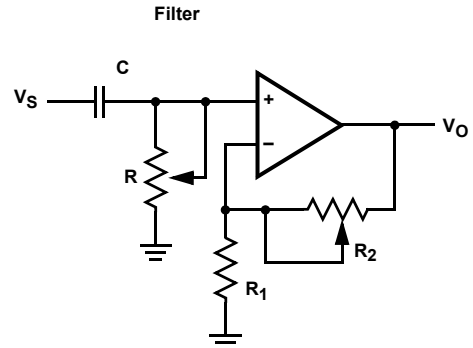

$$G_O = 1 + R_2/R_1$$

$$f_c = 1/(2\pi RC)$$

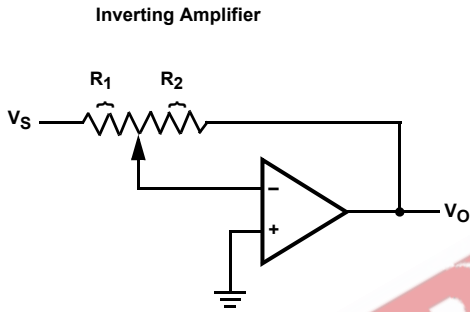

$$V_O = G V_S$$

$$G = -R_2/R_1$$

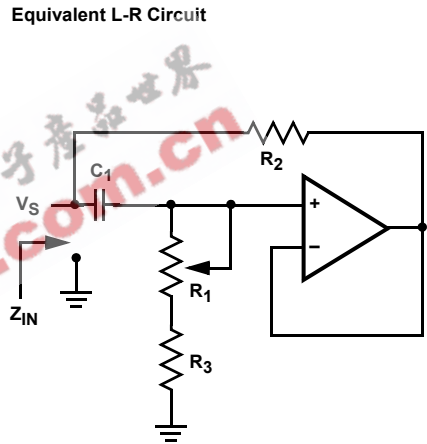

$$Z_{IN} = R_2 + s R_2 (R_1 + R_3) C_1 = R_2 + s L_{eq}$$

$$(R_1 + R_3) \gg R_2$$

Function Generator

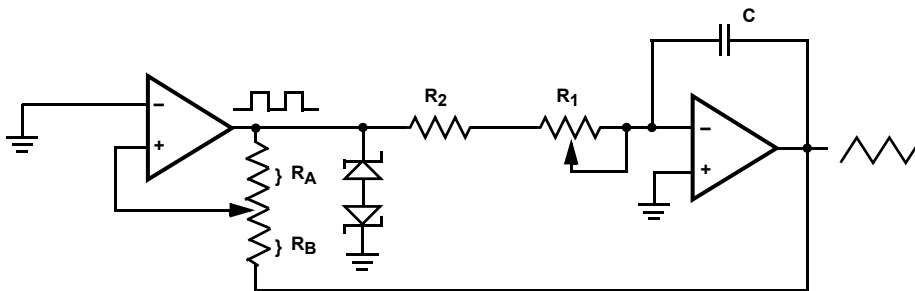

frequency $\propto R_1, R_2, C$
 amplitude $\propto R_A, R_B$

X9110

Packaging Information

14-Lead Plastic, TSSOP, Package Type V

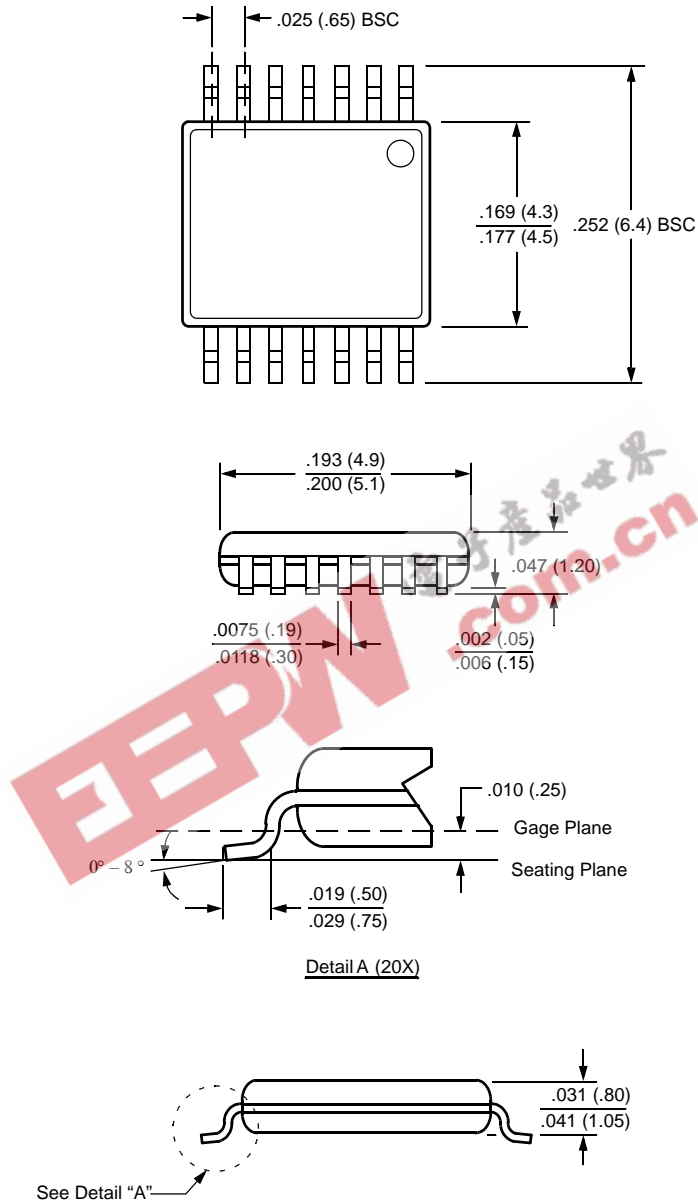

NOTE: ALL DIMENSIONS IN INCHES (IN PARENTHESES IN MILLIMETERS)

All Intersil U.S. products are manufactured, assembled and tested utilizing ISO9000 quality systems. Intersil Corporation's quality certifications can be viewed at www.intersil.com/design/quality

Intersil products are sold by description only. Intersil Corporation reserves the right to make changes in circuit design, software and/or specifications at any time without notice. Accordingly, the reader is cautioned to verify that data sheets are current before placing orders. Information furnished by Intersil is believed to be accurate and reliable. However, no responsibility is assumed by Intersil or its subsidiaries for its use; nor for any infringements of patents or other rights of third parties which may result from its use. No license is granted by implication or otherwise under any patent or patent rights of Intersil or its subsidiaries.

For information regarding Intersil Corporation and its products, see www.intersil.com