



## Low Profile SMD Type Crystal Units



This part is a miniature AT cut strip crystal unit packaged for surface mounting.

### FEATURES

- Low cost
- Industry standard
- Wide frequency range
- Excellent aging
- Surface mount

STANDARD ELECTRICAL SPECIFICATIONS						
PARAMETER	SYMBOL	CONDITION	UNIT	MIN	TYPICAL	MAX
Frequency Range	$F_o$		MHz	3.200		66.000
Frequency Tolerance	$\Delta F/F_o$	at 25°C	ppm	$\pm 10$	$\pm 30$	$\pm 50$
Temperature Stability	TC	ref to 25°C	ppm	$\pm 10$	$\pm 30$	$\pm 50$
Operating Temperature Range	$T_{OPR}$		°C	- 20*		+ 70*
Storage Temperature Range	$T_{STG}$		°C	- 40		+ 85
Shunt Capacitance	$C_o$		pF			7
Load Capacitance	CL	Customer Specified	pF	10		Series
Insulator Resistance	IR	100V <sub>DC</sub>	M $\Omega$	500		
Drive Level	DL		$\mu$ W		100	500
Aging	Fa	at 25°C, per year	ppm	- 5.0		+ 5.0

EQUIVALENT SERIES RESISTANCE (ESR) AND MODE OF VIBRATION (MODE)					
FREQUENCY RANGE(MHZ)	MAX ESR( $\Omega$ )	MODE	FREQUENCY RANGE(MHZ)	MAX ESR( $\Omega$ )	MODE
3.200 to 4.499	150	Fundamental/AT	9.000 to 9.999	60	Fundamental/AT
4.500 to 5.999	120	Fundamental/AT	10.000 to 12.999	50	Fundamental/AT
6.000 to 6.999	100	Fundamental/AT	13.000 to 30.000	40	Fundamental/AT
7.000 to 7.999	90	Fundamental/AT	30.000 to 66.000	80	3 <sup>rd</sup> Overtone
8.000 to 8.999	80	Fundamental/AT			

### DIMENSIONS in inches [millimeters]

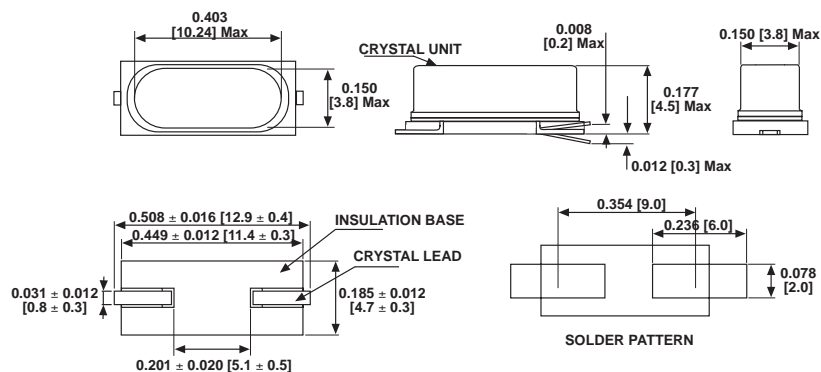

ORDERING INFORMATION			
XT49M MODEL	R OTR	- 20 LOAD	20M FREQUENCY/MHz
	Blank = Standard R = - 40°C to +85°C	Blank = Series - 20 = 20pF - 30 = 30pF - 32 = 32pF	