

SD5000 / SD5001 / SD5002 SD5400 / SD5401 / SD5402

FEATURES

- Low Propagation Time 600 psec
- Low On Resistance
- Low Insertion Loss
- Low Capacitance:
 - Analog Input 3.5pF typ.
 - Input (Gate) 2.4pF typ.
 - Output 1.3pF typ.
 - Feedback 0.3pF typ.
- Low Crosstalk -107dB @ 3kHz
- Bidirectional Operation

APPLICATIONS

- Analog Switching
- Audio Routing
- Sample & Hold
- Crosspoint Switches
- Choppers
- Video Switches

DESCRIPTION

The SD5000 Series are monolithic arrays of four bidirectional, high performance analog switches manufactured with implanted high-speed, high-voltage and low resistance double-difused MOS (DMOS) process. The maximum threshold of 2V permits simple TTL and CMOS driving in small signal applications.

ORDERING INFORMATION

Part	Package	Temperature Range
SD5000N	Plastic DIP Package	-55°C to +150°C
SD5001N	Plastic DIP Package	-55°C to +150°C
SD5002N	Plastic DIP Package	-55°C to +150°C
XSD5000	Sorted Chips in Carriers	-55°C to +150°C
XSD5001	Sorted Chips in Carriers	-55°C to +150°C
XSD5002	Sorted Chips in Carriers	-55°C to +150°C
SD5400CY	Plastic DIP Package	-55°C to +150°C
SD5401CY	Plastic DIP Package	-55°C to +150°C
SD5402CY	Plastic DIP Package	-55°C to +150°C
XSD5400	Sorted Chips in Carriers	-55°C to +150°C
XSD5401	Sorted Chips in Carriers	-55°C to +150°C
XSD5402	Sorted Chips in Carriers	-55°C to +150°C

FUNCTIONAL BLOCK DIAGRAM

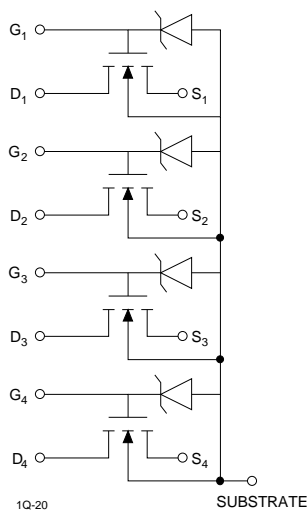

SO PIN CONFIGURATION

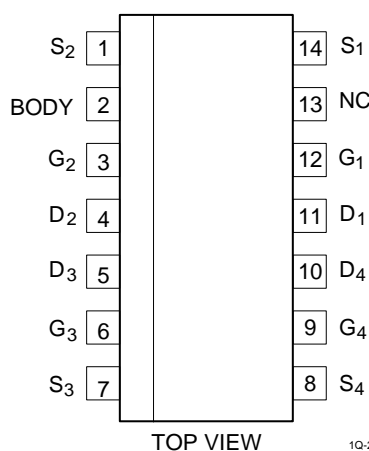

DUAL IN LINE PACKAGE

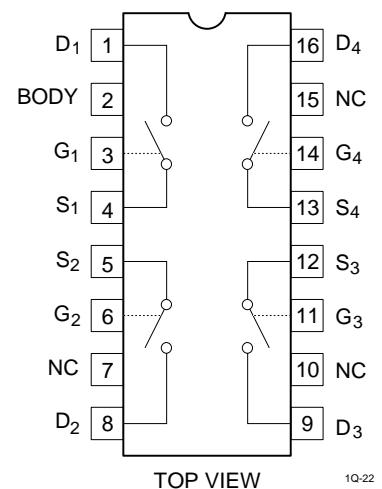

SD5000 / SD5001 / SD5002 SD5400 / SD5401 / SD5402



DC ELECTRICAL CHARACTERISTICS $T_A = 25^\circ\text{C}$

SYMBOL	PARAMETERS	SD5000/SD5400			SD5001/SD5401			SD5002/SD5402			UNITS	CONDITIONS
		MIN	TYP	MAX	MIN	TYP	MAX	MIN	TYP	MAX		
V_{analog}	Analog Signal Range	-10		+10	-5		+5	-7.5		+7.5	V	
Breakdown Voltage												
BV_{DS}	Drain-Source	20	25		10	25		15	25		V	$V_{\text{GS}} = V_{\text{BS}} = -5\text{V}$, $I_{\text{D}} = 10\text{nA}$ $V_{\text{GD}} = V_{\text{BD}} = -5\text{V}$, $I_{\text{S}} = 10\text{nA}$ $V_{\text{GB}} = 0\text{V}$, $I_{\text{D}} = 10\text{nA}$ Source Open $V_{\text{GB}} = 0\text{V}$, $I_{\text{S}} = 10\mu\text{A}$, Drain Open
BV_{SD}	Source-Drain	20			10			15				
BV_{DB}	Drain-Body	25			15			22.5				
BV_{SB}	Source-Body	25			15			22.5				
Leakage Current - SD5000/SD5400												
$I_{\text{DS(OFF)}}$	Drain-Source		1.0	10.0							nA	$V_{\text{GS}} = V_{\text{BS}} = -5\text{V}$, $V_{\text{DS}} = 20\text{V}$ $V_{\text{GD}} = V_{\text{BD}} = -5\text{V}$, $V_{\text{SD}} = 20\text{V}$ $V_{\text{DB}} = V_{\text{SB}} = 0\text{V}$, $V_{\text{GB}} = 30\text{V}$
$I_{\text{SD(OFF)}}$	Source-Drain		1.0	10.0							nA	
I_{GBS}	Gate			1.0							μA	
Leakage Current - SD5001/SD5401												
$I_{\text{DS(OFF)}}$	Drain-Source					1.0	10.0				nA	$V_{\text{GS}} = V_{\text{BS}} = -5\text{V}$, $V_{\text{DS}} = 10\text{V}$ $V_{\text{GD}} = V_{\text{BD}} = -5\text{V}$, $V_{\text{SD}} = 10\text{V}$ $V_{\text{DB}} = V_{\text{SB}} = 0\text{V}$, $V_{\text{GB}} = 25\text{V}$
$I_{\text{SD(OFF)}}$	Source-Drain					1.0	10.0				nA	
I_{GBS}	Gate						1.0				μA	
Leakage Current - SD5002/SD5402												
$I_{\text{DS(OFF)}}$	Drain-Source								1.0	10.0	nA	$V_{\text{GS}} = V_{\text{BS}} = -5\text{V}$, $V_{\text{DS}} = 15\text{V}$ $V_{\text{GD}} = V_{\text{BD}} = -5\text{V}$, $V_{\text{SD}} = 15\text{V}$ $V_{\text{DB}} = V_{\text{SB}} = 0\text{V}$, $V_{\text{GB}} = 30\text{V}$
$I_{\text{SD(OFF)}}$	Source-Drain								1.0	10.0	nA	
I_{GBS}	Gate									1.0	μA	
V_{T}	Threshold Voltage	0.1	1.0	2.0	0.1	1.0	2.0	0.1	1.0	2.0	V	$V_{\text{DS}} = V_{\text{GS}} = V_{\text{T}}$, $V_{\text{SB}} = 0\text{V}$, $I_{\text{D}} = 1\mu\text{A}$
$R_{\text{DS(ON)}}$	Drain-Source ON Resistance		50	70		50	70		50	70	Ω	$V_{\text{GS}} = 5\text{V}$, $V_{\text{SB}} = 0\text{V}$, $I_{\text{D}} = 1\text{mA}$ $V_{\text{GS}} = 10\text{V}$, $V_{\text{SB}} = 0\text{V}$, $I_{\text{D}} = 1\text{mA}$ $V_{\text{GS}} = 15\text{V}$, $V_{\text{SB}} = 0\text{V}$, $I_{\text{D}} = 1\text{mA}$ $V_{\text{GS}} = 20\text{V}$, $V_{\text{SB}} = 0\text{V}$, $I_{\text{D}} = 1\text{mA}$
$R_{\text{DS(ON)}}$	Match ON Resiatance		1	5		1	5		1	5	Ω	$V_{\text{GS}} = 5\text{V}$

AC ELECTRICAL CHARACTERISTICS $T_A = 25^\circ\text{C}$

SYMBOL	PARAMETER	MIN	TYP	MAX	UNITS	CONDITIONS
g_{fs}	Forward Transconductance	10	12		mS	$V_{\text{DS}} = 10\text{V}$, $I_{\text{D}} = 20\text{mA}$, $V_{\text{SB}} = 0\text{V}$, $f = 1\text{kHz}$
Capacitances						
C_{G}	Gate Node		2.4	3.5	pF	$V_{\text{DS}} = 10\text{V}$, $f = 1\text{MHz}$, $V_{\text{GS}} = V_{\text{BS}} = -15\text{V}$
C_{D}	Drain Node		1.3	1.5		
C_{S}	Source Node		3.5	4.0		
C_{DG}	Reverse Transfer		0.3	0.5		
C_{T}	Crosstalk		107.0		dB	$f = 3\text{kHz}$, $R_{\text{G}} = 600\Omega$

SWITCHING CHARACTERISTICS $T_A = 25^\circ\text{C}$

SYMBOL	PARAMETER	MIN	TYP	MAX	UNITS	CONDITIONS
$t_{\text{d(ON)}}$	Turn-On Time		0.7	1.0	nsec	$R_{\text{L}} = 680\Omega$, $R_{\text{G}} = 51$ $V_{\text{DD}} = 5\text{V}$ $V_{\text{G(ON)}} = 10\text{V}$
t_{r}	Rise Time		0.8	1.0		
t_{OFF^*}	Turn-Off Time		10.0			

* t_{OFF} is dependent on R_{L} and C and does not depend on the device characteristics.



**SD5000 / SD5001 / SD5002
SD5400 / SD5401 / SD5402**

ABSOLUTE MAXIMUM RATINGS

SYMBOL	PARAMETER	SD5000/SD5400 MAX. VALUE	SD5001/SD5401 MAX. VALUE	SD5002/SD5402 MAX. VALUE	UNITS
Breakdown Voltage					
V _{DS}	Drain-Source	20	10	15	V
V _{SD}	Source-Drain	20	10	15	
V _{DB}	Drain-Body	25	15	22.5	
V _{SB}	Source-Body	25	15	22.5	
V _{GS}	Gate-Source	30/ - 25	25/ - 15	30/ - 22.5	
V _{GB}	Gate-Body	30/ - 0.3	25/ - 0.3	30/ - 0.3	
V _{GD}	Gate-Drain	30/ - 25	30/ - 15	30/ - 22.5	

ABSOLUTE MAXIMUM

SYMBOL	PARAMETER	VALUE	UNIT
I _D	Drain Current	50	mA
Temperature Range			
T _J	Operating	-55 to +85	°C
T _S	Storage	-55 to +150	
Power Dissipation			
P _D	Package	640 (Note 1)	mW
P _D	Each Device	300 (Note 2)	

Note 1: Linear Derating Factor - 10.7mW/°C above 25°C

Note 2: Linear Derating Factor - 5.0mW/°C above 25°C