

### Description

The YB1508 is a step-up DC-DC converter, acting as current source to drive up to 8 white LEDs in series. Series connecting of the LEDs provides identical LED currents resulting in uniform brightness and eliminating the need for ballast resistors. The light intensity of these LEDs is proportional to the current passing through them. Additional features include output over voltage protection to prevent device damage due to faulty LED or open circuit caused by abnormal conditions, and one-pin shutdown and multiple methods of dimming control.

The YB1508 switches at a fixed frequency of 1MHz, allowing the use of tiny external components and low input noise and ripple. To control LED brightness, the LED current can be pulsed by applying a PWM (pulse width modulated) signal with a frequency range of 100Hz to 50KHz to the CTRL pin. The YB1508 is available in a low profile 5-lead SOT-23 package.

### Features

- 2.7V to 9V input range
- Adjustable output voltage up to 40V
- Built in internal switch
- Inherently matched LED current
- Fixed frequency of 1MHz PWM operation
- Open LED protection
- Low profile 5-Lead SOT-23 package
- High efficiency: over 80% at 3.6V input voltage
- Drives up to 8 white LEDs

### Applications

- LCD Display Module
- OLED panel/sub-panel
- White LED Backlighting
- Digital Camera
- Cellular Phone
- Portable Application

### Typical Application Circuit

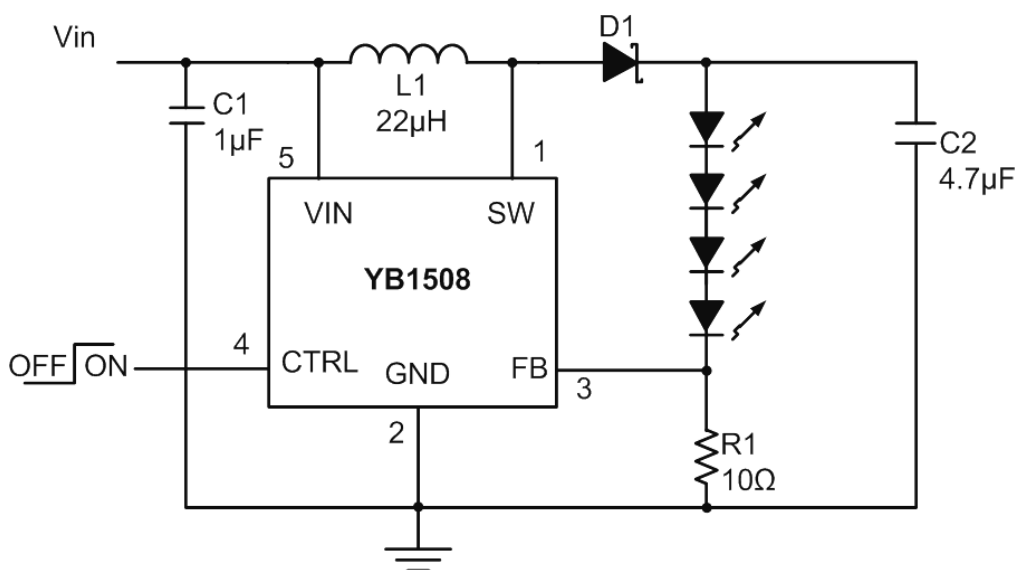

Figure 1 : Typical Application Circuit

## Pin Description

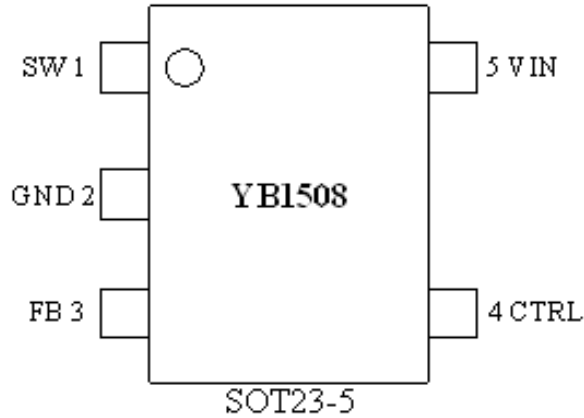

Figure 2 : YB1508 SOT23-5

## Pin Designator

Table 1 :

Pin	Name	Description
1	SW	Switching Pin. This is the collector of the internal NPN power switch. Connect to inductor and diode. Minimize the metal trace area connected to this pin to reduce EMI.
2	GND	Ground Pin. Connect directly to local ground plane.
3	FB	Feedback Pin. Reference voltage is 200mV. Connect LEDs and a resistor at this pin. LED current is determined by the resistance and CTRL voltage.
4	CTRL	Shutdown Pin and Dimming Control pin. A. $V_{CTRL} > 1.8V$ generates full-scale LED current B. $V_{CTRL} < 0.4V$ chip is off C. Switching from 0.4V to 2.0V, PWM duty cycle controls the LED current
5	VIN	Input Supply Pin. Bypass this pin with a capacitor as close to the device as possible.

## Ordering Information

Table 2:

Order Number		Package Type	Supplied as	Package Marking
High Ovp	YB1508	SOT23-5	3000 units Tape & Reel	Y58
Low Ovp	YB1508P	SOT23-5	3000 units Tape & Reel	Y58P

### Absolute Maximum Ratings

SW voltage	40V	Maximum Junction Temp, T <sub>j</sub>	150 °C
All other pins	10V	Lead Temperature (Soldering 10 sec)	300 °C
		Thermal Resistance	195 °C

### Electricity Characteristics

Table 3 : (T<sub>A</sub>=25°C, V<sub>in</sub>=3.3V C<sub>in</sub>=1uF C<sub>out</sub>=4.7uF unless otherwise noted)

Function Parameter	Conditions	Min	Typ	Max	Units
Input Voltage Range		2.7		9	V
Feedback Voltage	I <sub>out</sub> = 20mA, V <sub>out</sub> = 12.5V Circuit of figure 1. (L=22uH C <sub>out</sub> = 4.7uF) R <sub>fb</sub> = 10 ohms	180	200	220	mV
FB Pin Bias current		2	10	20	μA
Supply current	V <sub>fb</sub> = 0.3V		3.5		mA
	CTRL = 0V		1		μA
Switching Frequency		0.7	0.8	1.3	MHz
Maximum Duty Cycle				93	%
Minimum duty cycle		20	25	35	%
Switch V <sub>cesat</sub>	At I <sub>sw</sub> = 200mA		200		mV
Switch Current Limit	40% duty cycle		250		mA
Switch Leakage Current	Ctrl = 0.3V		1		μA
V <sub>CTRL</sub> for Full LED current		1.6	1.7	1.8	V
CTRL Pin Bias Current	Ctrl = 2V		20		μA
Chip turn off delay				30	μS
Over Voltage Protection	YB1508		36		V
	YB1508P		21		

## Functional Block Diagram

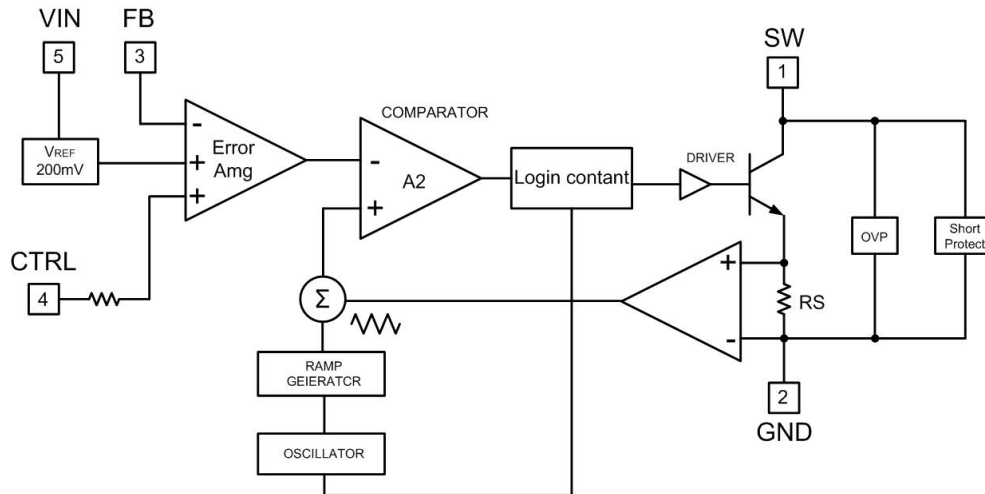

Figure 3. Block Diagram

## Application Information

### Operation

The operation of YB1508 can be understood by referring to the block diagram in Figure 3. A voltage proportional to the switch current is added to a ramp output and the resulting sum is fed into the positive terminal of the PWM comparator. When this voltage exceeds the level of the comparator negative input, the peak current has been reached, and the SR latch is reset and turns off the power switch. The voltage at the negative input of the comparator comes from the output of the error amplifier. The error amplifier sets the correct peak current level to keep the output in regulation. If the error amplifier's output increases, more current is delivered to the output; if it decreases, less current is delivered.

### Inductor Selection

A 22uH inductor is recommended for most YB1508 applications. Although

small size and high efficiency are major concerns, the inductor should have low core losses at 1MHz and low DCR (copper wire resistance).

### Capacitor Selection

The small size of ceramic capacitors makes them ideal for YB1508 applications. X5R and X7R types are recommended because they retain their capacitance over wider voltage and temperature ranges than other types.

### Diode selection

To maintain high efficiency, the average current rating of the schottky diode should be larger than the peak inductor current, IPK. Schottky diode with a low forward drop and fast switching speeds are ideal for increasing efficiency in portable applications. The reverse breakdown voltage of the schottky diode must be larger than the output voltage.

**Inrush Current**

The maximum switch current is limited to about 300 mA by the chip. Typically, this large current will occur for about 40us during start up. A larger Cout will increase the duration of high current. However, when Vin is first connected, an even larger current can flow into Cout. This occurs when the SW pin is open circuit and the Cout voltage changes from 0V to Vin in a few microseconds. Because the duration of this large current is short, it will usually not cause problems.

**LED Current and Dimming Control**

The LED current can be reduced by pulse width modulating the CTRL voltage from 0.4V to 1.8V. Using the PWM mode, the LED current can be controlled from 0% to 100%.

**Open Circuit Protection**

The YB1508 has an internal open-circuit

protection circuit. When the LEDs are disconnected from the circuit or fail open, the YB1508 will then shutdown until Vin goes low or CTRL goes lower than 0.4V. **Different maximum Vout can be requested from YoBon.**

**Board Layout Consideration**

To maximize efficiency, rise and fall times of switch should be made as short as possible. Proper layout of the high frequency switching path is important to prevent electromagnetic interference (EMI) problems. Place COUT close to the VOUT pin. A ground plane under the switching regulator is needed to minimize interplane coupling. In addition, the feedback resistor Rs should be tied directly to the GND Pin without any other connection to ensure a clean, noise-free connection.

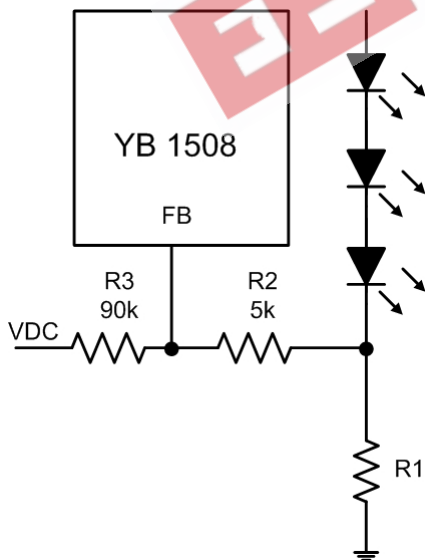

Figure 4. Dimming Control Using a DC Voltage

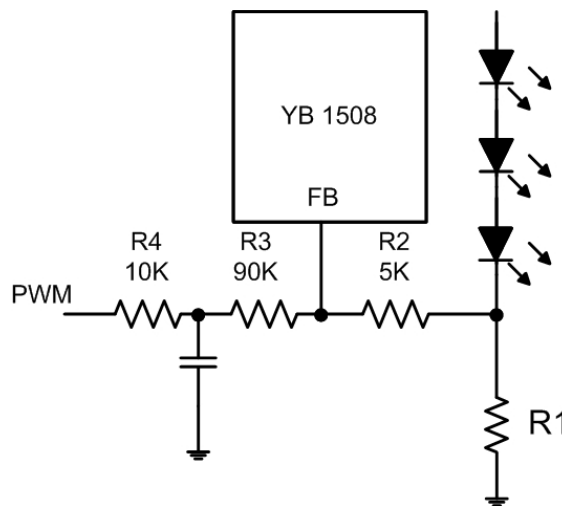

Figure 5. Dimming Control Using a Filtered PWM Signal

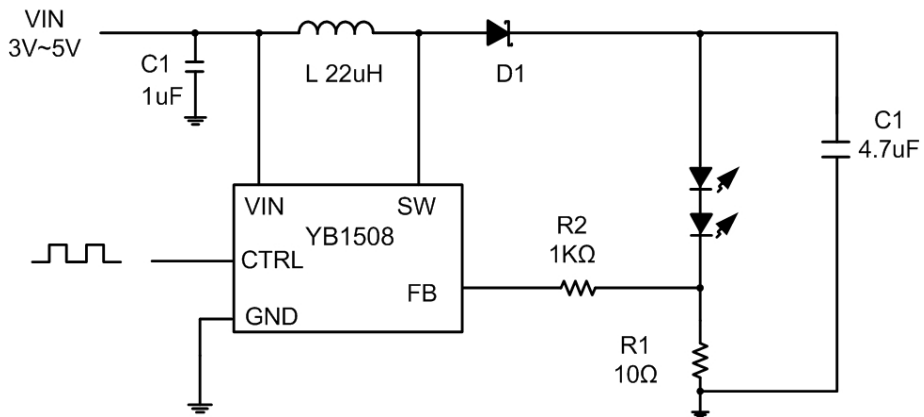

Figure 6. Li-Ion to Two White LEDs Application Circuit

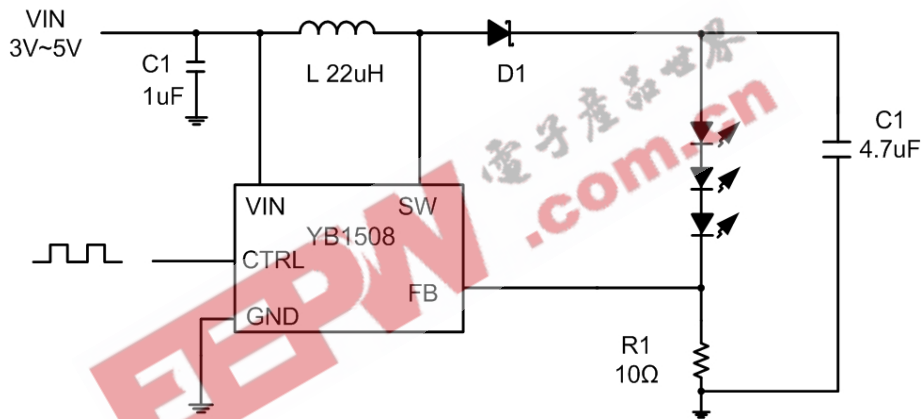

Figure 7. Li-Ion to Three White LEDs Application Circuit

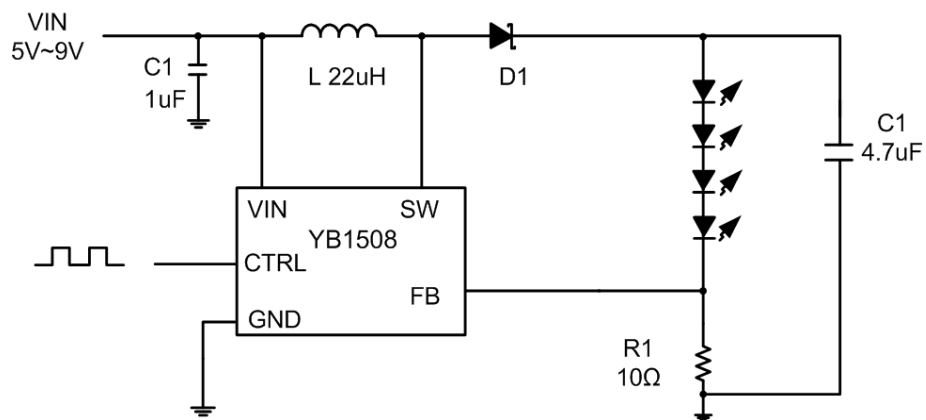
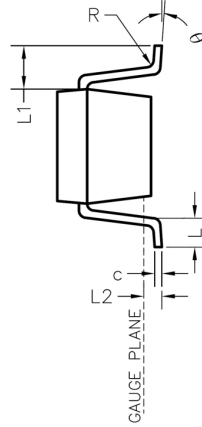
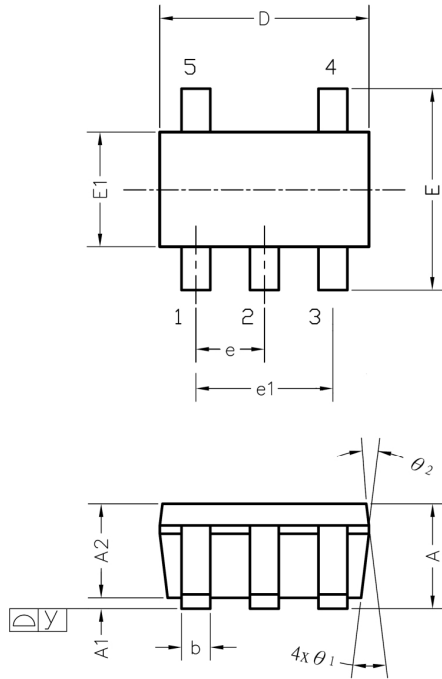

Figure 8. Four White LEDs Application Circuit

### SOT-25 Package Information



Symbol	inch			mm		
	Min	Nom	Max	Min	Nom	Max
A	0.041	-	0.053	1.05	-	1.35
A1	0.002	-	0.006	0.05	-	0.15
A2	0.039	0.043	0.047	1.00	1.10	1.20
b	0.012	-	0.020	0.30	-	0.50
c	0.003	-	0.008	0.08	-	0.20
D	0.110	0.114	0.118	2.80	2.90	3.00
E	0.102	0.110	0.118	2.60	2.80	3.00
E1	0.059	0.063	0.067	1.50	1.60	1.70
e	0.0374 BSC			0.95 BSC		
e1	0.0748 BSC			1.90 BSC		
L	0.014	0.018	0.022	0.35	0.45	0.55
L1	0.0236 REF			0.60 REF		
L2	0.0098 BSC			0.25 BSC		
y	-	-	0.004	-	-	0.10
R	0.004	-	-	0.10	-	-
$\theta$	0°	-	8°	0°	-	8°
$\theta_1$	7° NOM			7° NOM		
$\theta_2$	5° NOM			5° NOM		

- Note:
- JEDEC spec outline : MO-178C
  - Dimension D does not include mold flash, protrusions or gate burrs. Mold flash, protrusions or gate burrs shall not exceed 0.10 mm PER end. Dimension E1 does not include interlead flash or protrusion. Interlead flash or protrusion shall not exceed 0.15 mm PER side.
  - The package top may be smaller than the package bottom. Dimensions D and E1 are determined at the outermost extremes of the plastic body exclusive of mold flash, tie bar burrs, gate burrs and interlead flash, but including any mismatch between the top and bottom of the plastic body.
  - Pin2 or Pin1-3 may intend to be wider for Pin1 side identification.

All the contents in this datasheet are not assuming any responsibility for use of any circuitry described, no circuit patent license are implied and Yobon reserves the right at any time without notice to change said circuitry and specifications.