

DUAL OPERATIONNAL AMPLIFIER—YD358

DESCRIPTION

The YD358 consists of dual independent, high Gain internally frequency compensated operational amplifiers which were designed specifically to operation from a single power supply over a wide voltage range.

FEATURES

- *Internally frequency compensated for unity gain;
- *Large DC voltage gain: 100dB;
- *Wide operating supply range ($V_{cc}=3V\sim 32V$);
- *Input common-mode voltage includes ground;
- *Large output voltage swing: from 0V to $V_{cc}-1.5V$;
- *Power drain suitable for battery operation.

BLOCK DIAGRAM

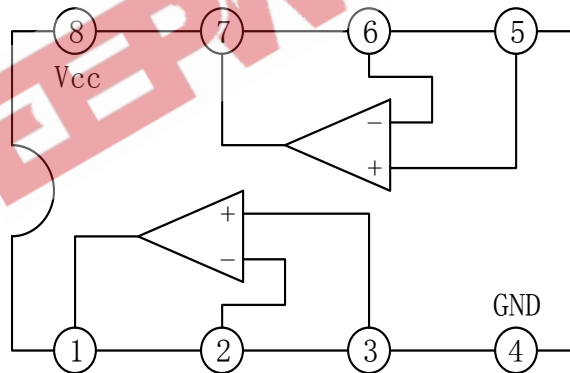

WuXi YouDa Electronics Co., Ltd

Add: No.5 Xijin Road, National Hi-Tech Industrial Development Zone, Wuxi Jiangsu China
Tel: 86-510-85205117 86-510-85205106 Fax: 86-510-85205110 Website: www.e-youda.com
SHENZHEN OFFICE Tel: 86-755-83740369 Fax: 86-755-83741418

ABSOLUTE MAXIMUM RATINGS (Tamb=25°C)

PARAMETER	SYMBOL	VALUE	UNIT
Supply Voltage	V _{CC}	32	V
Differential Input Voltage	V _{I(DIFF)}	±32	V
Input Voltage	V _I	-0.3~32V	V
Power Dissipation(DIP8)	P _{D1}	570	mW
Power Dissipation(SOP8)	P _{D2}	260	mW
Operating Temperature	Topr	0 ~ +70	°C
Storage Temperature	Tstg	-65 ~ +150	°C

ELECTRICAL CHARACTERISTICS

(Ta=25°C, V_{CC}=5.0V, all voltage referenced to GND unless otherwise specified)

PARAMETER	SYMBOL	TEST CONDITIONS	MIN	TYP	MAX	UNIT
Input Offset Voltage	V _{IO}	V _{CM} =0 to V _{CC} -1.5 V _{O(P)} =1.4V, R _S =0		3.0	7.0	mV
Input Offset Current	I _{IO}			2.0	50	nA
Input Bias Current	I _b			20	250	nA
Input Common-mode Voltage Range	V _{I(R)}	V _{CC} =30V	0		V _{CC} -1.5	V
Supply Current	I _{CC}	R _L =∞, V _{CC} =30V,		0.8	2.0	mA
		V _{CC} =5V		0.5	1.2	mA
Large Signal Voltage Gain	G _v	V _{CC} =15V, R _L >2kΩ V _{O(P)} =1V to 11V	25	100		V/mV
Output Voltage Swing	V _(OH)	V _{CC} =30V, R _L =2kΩ	26			V
		V _{CC} =30V, R _L =10kΩ	27	28		V
	V _(OL)	V _{CC} =5V, R _L >10kΩ		5	20	mV
Common-mode Rejection Ratio	CMRR		65	80		dB
Power Supply Rejection Ratio	PSRR		65	100		dB
Channel Separation	CS	f=1kHz to 20kHz		5	20	mV
Short Circuit To GND	I _{sc}			40	60	mA
Output Current	I _{source}	V _{I(+)} =1V, V _{I(-)} =0 V _{CC} =15V, V _{O(P)} =2V	20	40		mA
Output Current	I _{sink}	V _{I(+)} =0V, V _{I(-)} =1V V _{CC} =15V, V _{O(P)} =2V	10	20		mA
		V _{I(+)} =0V, V _{I(-)} =1V V _{CC} =15V, V _{O(P)} =200mV	12	50		μA
Differential Input Voltage	V _{ID}				V _{CC}	V

OUTLINE DRAWING

DIP-8

unit:mm

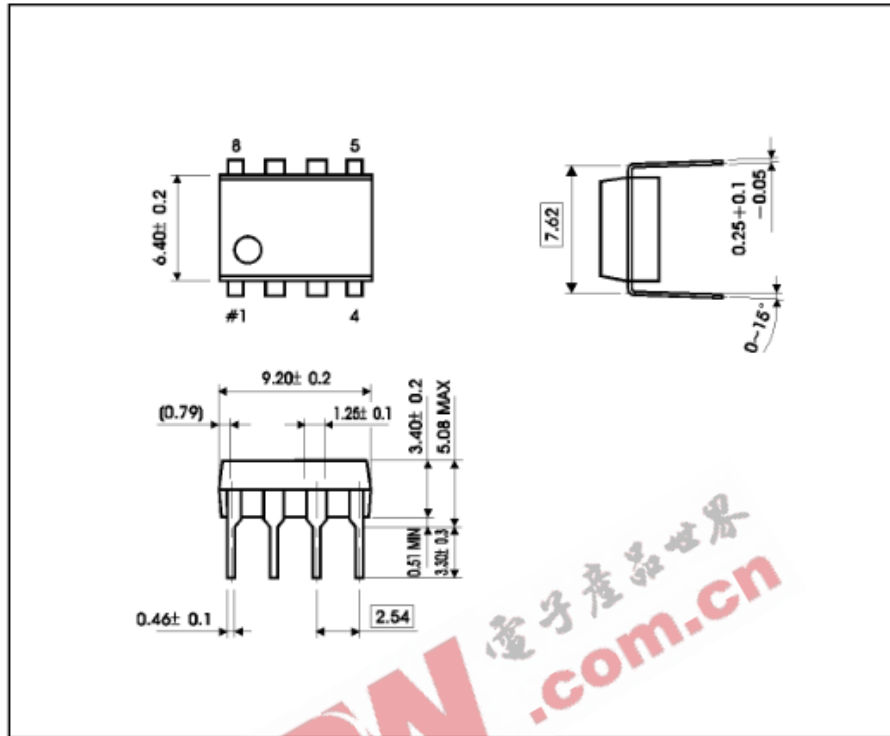

SOP-8

unit:mm

