

FOUR OPERATIONAL AMPLIFIER-YD324

DESCRIPTION AND FEATURES

These devices consist of four independent high-gain, phase –compensated operational amplifiers. A suitable recorder and Audio System for tone control. Can also used for telecom and instrument.

- *Built-in phase-compensated circuit
- *Operating supply voltage range : $V_{CC}=3.0\sim 30.0V$ or $V_{CC}=\pm 1.5\sim \pm 15V$
- *Input voltage can low to 0V
- *Output voltage range : $0V\sim V_{CC}-1.5V$
- *Supply current : $I_{CC}=0.6mA (R_L=\infty)$
- *DIP14 and SOP14

BLOCK DIAGRAM

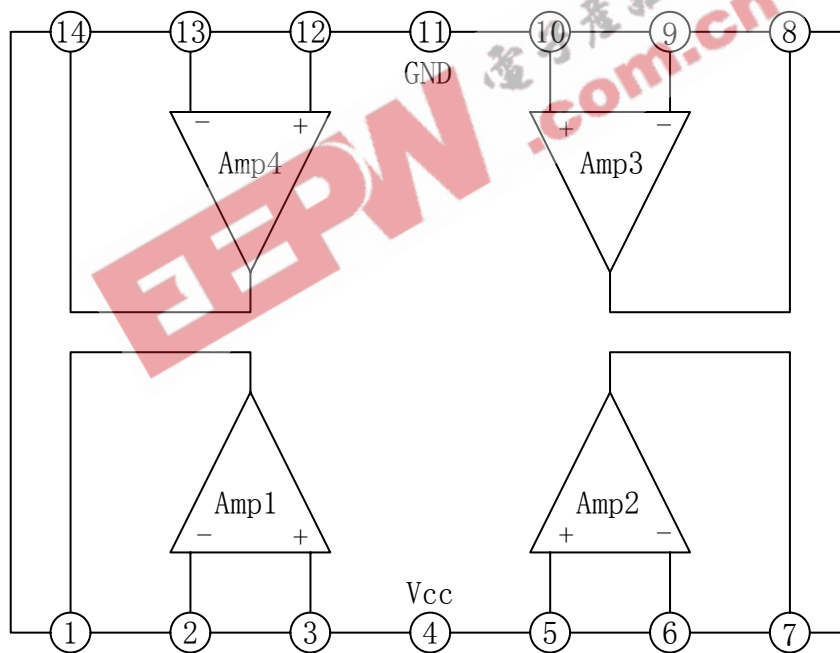

WuXi YouDa Electronics Co., Ltd

Add: No.5 Xijin Road, National Hi-Tech Industrial Development Zone, Wuxi Jiangsu China
 Tel: 86-510-5205117 86-510-5205106 Fax: 86-510-5205110 Website: www.e-youda.com
 SHENZHEN OFFICE Tel: 86-755-83740369 Fax: 86-755-83741418

PIN DESCRIPTION

PIN NO.	CONTENT	SYMBOL	PIN NO.	CONTENT	SYMBOL
1	Output of CH1	OUT ₁	8	Output of CH3	OUT ₃
2	Inverting Input of CH1	1N-(1)	9	Inverting Input of CH3	1N-(3)
3	Non-inverting Input of CH1	1N+(1)	10	Non-inverting Input of CH3	1N+(3)
4	Supply Voltage	V _{CC}	11	Ground	GND
5	Non-inverting Input of CH2	1N+(2)	12	Non-inverting Input of CH4	1N+(4)
6	Inverting Input of CH2	1N-(2)	13	Inverting Input of CH4	1N-(4)
7	Output of CH2	OUT ₂	14	Output of CH4	OUT ₄

ABSOLUTE MAXIMUM RATINGS

PARAMETER	SYMBOL	VALUE		UNIT
		MIN	MAX	
Supply Voltage	V _{CC}		32	V
Differential Input Voltage	V _{ID}		32	V
Input Voltage	V _I	-0.3	32	V
Total Dissipation(DIP14)	P _{D1}		720	mW
Total Dissipation(SOP14)	P _{D2}		300	mW
Operating Temperature Range	Topr	-30	85	°C
Storage Temperature Range	Tstg	-55	125	°C

ELECTRICAL CHARACTERISTICS (T_{amb}=25°C, V_{CC}=9V, Unless otherwise specified)

PARAMETER	SYMBOL	TEST CONDITION	MIN	TYP	MAX	UNIT
Input Offset Voltage	V _{IO}			±2	±7	mv
Input Offset Current	I _{IO}			±5	±50	nA
Input Bias Current	I _{IB}			45	250	
Common-mode Input Voltage Range	V _{ICM}		0		V _{CC} -1.5	V
Common-mode Rejection Ratio	K _{CmR}		65	80		dB
Open Loop Voltage Gain	A _{VO}	V _{CC} =15V, R _L ≥ 2k Ω	88	100		
Output Voltage Range	V _O		0		V _{CC} -1.5	V

PARAMETER	SYMBOL	TEST CONDITION	MIN	TYP	MAX	UNIT
Supply Voltage Rejection Ratio	K_{SVR}		65	100		dB
Output Current	I_{OS}		20	40		mA
Output Current Of Sink	I_{OSINK}		10	20		
Supply Current	I_{CCQ}			0.6	2	
Supply Current	I_{CCQ}	$V_{CC}=30V$		1.5	3	
Channel Separation	C_S	$f=1k\sim 20kHz$		120		dB

APPLICATION CIRCUIT

DC AMPLIFICATION

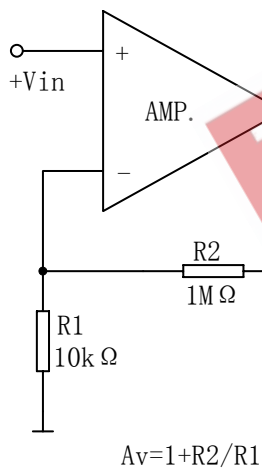

AC AMPLIFICATION

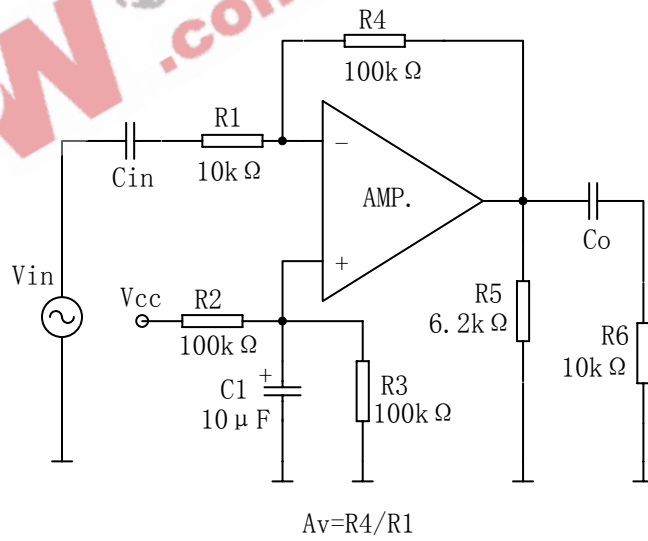

OUTLINE DRAWING

DIP-14

unit:mm

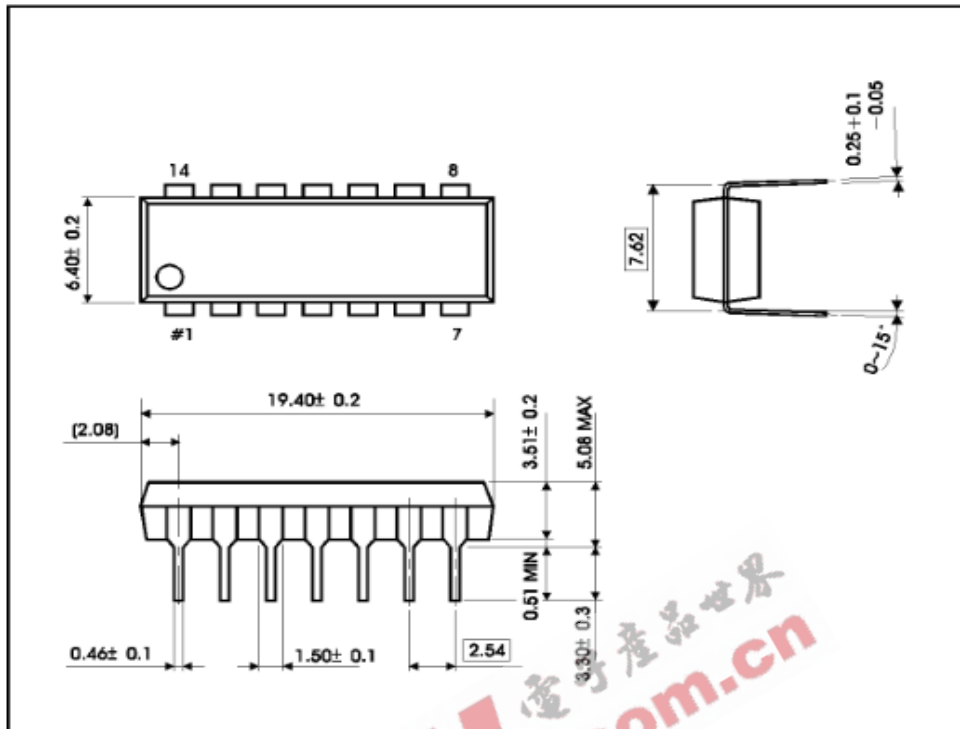

SOP-14

unit:mm

