

POWER AMPLIFIER FOR HEADPHONE STEREOS—YD7000

DESCRIPTION

The YD7000 is a low power audio amplifier integrated circuit for headphone. It provides differential speaker outputs to maximize output swing at low supply voltages.

FEATURES

- *Low current consumption.
- *16 load drive capability.
- *Excellent reduced voltage characteristics.
- *Excellent power supply ripple rejection.
- *Minimum number of external parts required (no input capacitor, feedback capacitor required).
- *Applicable to radio sets because of high voltage gain.
- *Less harmonic interference in radio band.
- *On-chip power switch function, muting function.

BLOCK DIAGRAM

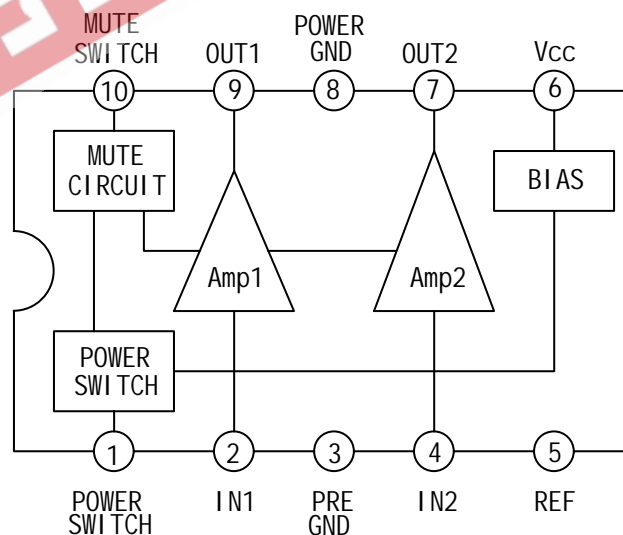

WuXi YouDa Electronics Co., Ltd

Add: No.5 Xijin Road, National Hi-Tech Industrial Development Zone, Wuxi Jiangsu China

Tel: 86-510-5205117 86-510-5205108 Fax: 86-510-5205110 Website: www.e-youda.com

SHENZHEN OFFICE Tel : 86-755-83740369 13823533350 Fax : 86-755-83741418

ABSOLUTE MAXIMUM RATINGS ($T_{amb}=25$)

PARAMETER	SYMBOL	VALUE	UNIT
Supply Voltage	V_{cc}	4.5	V
Allowable Power Dissipation	P_D	300	mW
Operating Temperature	T_{opr}	-20 ~ +75	
Storage Temperature	T_{stg}	-40 ~ +125	

RECOMMENDED OPERATING CONDITIONS ($T_{amb}=25$)

PARAMETER	SYMBOL	VALUE	UNIT
Supply Voltage	V_{cc}	3.0	V
Operating Voltage Range	V_{cc}	1.6 ~ 4.0	V
Recommended Load Resistance	R_L	16 ~ 32	

ELECTRICAL CHARACTERISTICS

($T_{amb}=25$, $R_L=16$, $R_g=600$, See specified Test Circuit.)

PARAMETER	SYMBOL	TEST CONDITIONS	MIN	TYP	MAX	UNIT
Quiescent Current	$I_{cco(1)}$	$V_{cc}=2.4V$, quiescent		5.4	10	mA
	$I_{cco(2)}$	$V_{cc}=4.5V$, pin10 GND		1.1	2.0	mA
	$I_{cco(3)}$	$V_{cc}=4.5V$, pin1 GND			1.0	μA
Voltage Gain	$G_v(1)$	$V_{cc}=2.4V$, $f=1kHz$, $V_o=-10dBm$	30	32	34	dB
	$G_v(2)$	$V_{cc}=1.6V$, $f=1kHz$, $V_o=-20dBm$	29	32	34	dB
Voltage Gain Difference	$G_v(1)$	$V_{cc}=2.4V$, $f=1kHz$, $V_o=-10dBm$			1.0	dB
	$G_v(2)$	$V_{cc}=1.6V$, $f=1kHz$, $V_o=-20dBm$			1.0	dB
Total Harmonic Distortion	THD	$V_{cc}=2.0V$, $f=1kHz$, $P_o=1mW$		0.5	1.5	%
Output Power	P_o	$V_{cc}=3.0V$, $f=1kHz$, THD=10%	20	40		mW
Crosstalk	CT	$V_{cc}=2.4V$, $f=100Hz$, $R_g=1K$ $V_o=-10dB$	40	50		dB
Ripple Rejection	SVRR	$V_{cc}=1.6V$, $f=100Hz$, $R_g=1K$ $V_R=-20dBm$, BPF=100Hz	45	60		dB
Output Noise Voltage	V_{NO}	$V_{cc}=4.5V$, $R_g=1K$ BPF=20Hz ~ 20kHz		62	100	μV
Power OFF Effect	$V_{O(off)}$	$V_{cc}=1.6V$, $f=100Hz$, pin1 GND, $V_{IN}=-10dB$			-80	dB

Muting Effect	$V_{O(MT)}$	$V_{CC}=1.6V, f=100Hz, \text{pin}10 \text{ GND}, V_{IN}=-10dB$			-80	dB
Power ON Current Sensitivity	$I_1(\text{on})$	$V_{CC}=1.5V, V_5 \ 0.85V$		0.05	1.0	μA
Power OFF Voltage Sensitivity	$V_1(\text{off})$	$V_{CC}=1.5V, V_5 \ 0.1V$	0.5	0.6		V
Muting OFF Current Sensitivity	$I_{10}(\text{off})$	$V_{CC}=1.5V, V_5 \ 0.85V$		0.2	1.0	μA
Muting ON Voltage Sensitivity	$V_{10}(\text{on})$	$V_{CC}=1.5V, V_5 \ 0.1V$	0.5	0.65		V

APPLICATION CIRCUIT

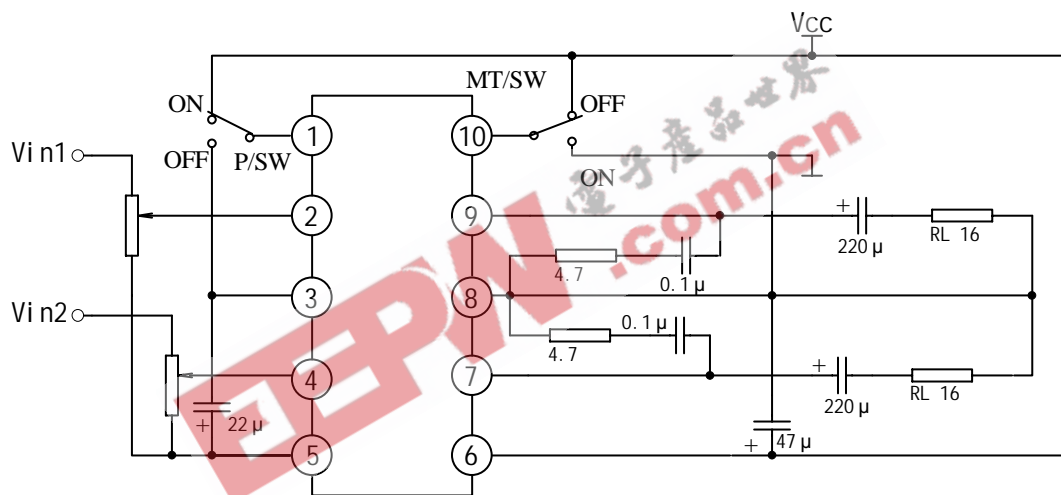

OUTLINE DRAWING

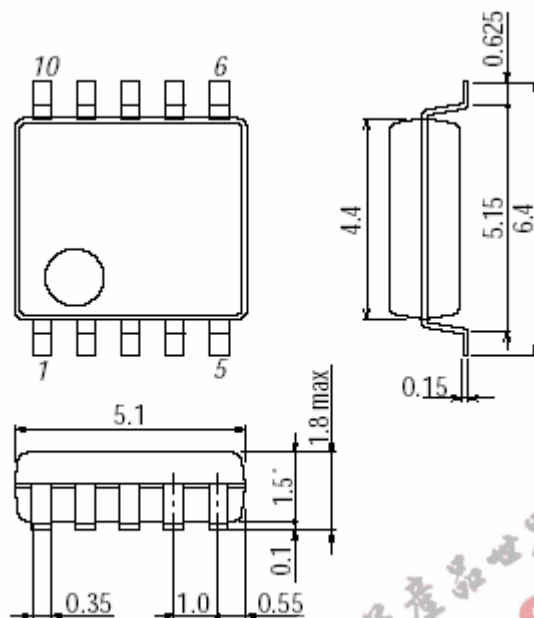

EEPW.com.cn 电子产品世界