

YMZ284

Software-controlled Sound Generator (SSGL)

■ OVERVIEW

The YMZ284(SSGL) is a melody and effect sound generator LSI, having square wave, noise and envelope generators.

The YMZ284 is packaged in 16-pin DIP with easy control, eliminating the I/O port and improving CPU interface from the YM2149 (SSG).

■ FEATURES

- Three sequence square wave generators and one noise generator, software-compatible with the YM2149(SSG)
- 3 built-in 5-bit D/A convertors and mixed output
- CPU interface through /CS, /WR control signal and 8 bit data bus
- Wide voicing range of 8 octaves
- Smooth attenuation by wide dynamic range envelope generator
- Power down mode
- +5V single power supply, silicon gate CMOS process
- 16-pin plastic DIP(YMZ284-D) or 16-pin plastic SOP (YMZ284-M).

■ PIN OUT DIAGRAM

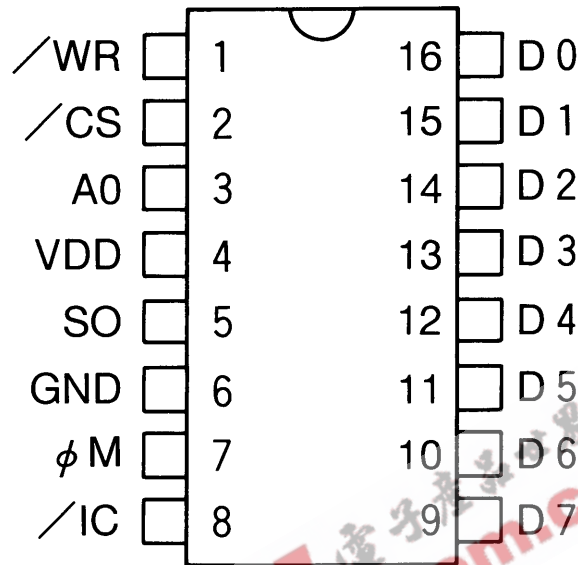

Top View (16pin DIP, 16pin SOP)

■ PIN DESCRIPTION

No	Name	I/O	Function
1	/WR	I	CPU interface Write enable
2	/CS	I	CPU interface Chip select
3	A 0	I	CPU interface Address/Data select
4	VDD	-	+5V power supply
5	SO	O	D/A convertor output for SSG
6	GND	-	Ground
7	φ M	I	Master clock input
8	/IC	I+	Initial clear input
9	D 7	I	CPU interface data bus (MSB)
10	D 6	I	CPU interface data bus
11	D 5	I	CPU interface data bus
12	D 4	I	CPU interface data bus
13	D 3	I	CPU interface data bus
14	D 2	I	CPU interface data bus
15	D 1	I	CPU interface data bus
16	D 0	I	CPU interface data bus (LSB)

Note) I+ : Built-in pull-up resistor

■BLOCK DIAGRAM

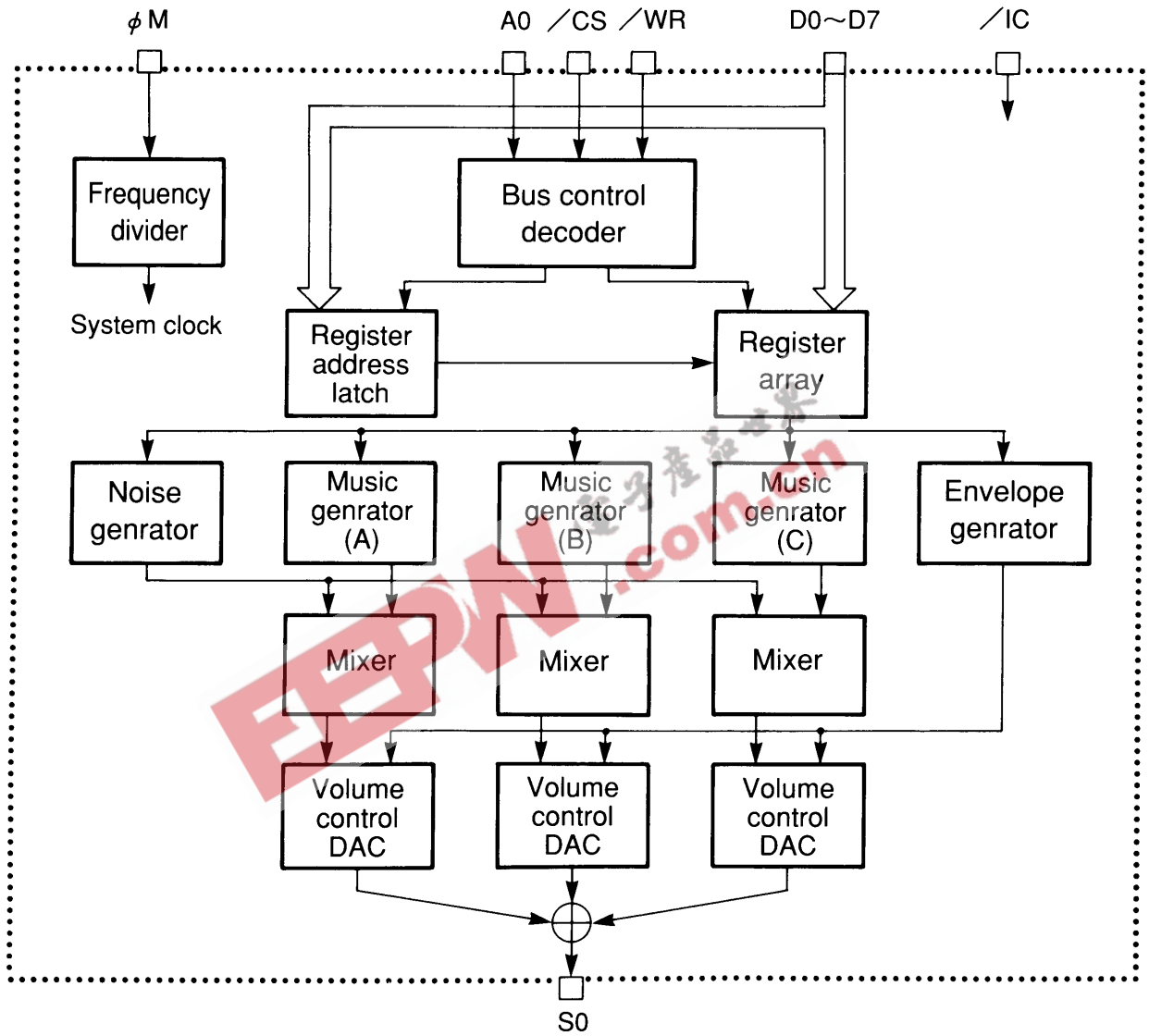

■FUNCTIONS

- 1. ϕM
Master clock input pin.
Frequency is 1MHz to 4MHz.

- 2. D0 ~ D7
8 bit data bus.

- 3. \overline{CS} · \overline{WR} · A0
Control write address and data from 8 bit data bus.

\overline{CS}	\overline{WR}	A0	Function
L	L	L	Address write mode
L	L	H	Data write mode

- 4. \overline{IC}
'L' level resets the system clearing all register values.

- 5. SO
Analog output pin

- 6. VDD
+5V power supply pin

- 7. GND
Ground pin



■FUNCTION DESCRIPTION

All functions of SSGL are controlled by the 15 internal registers.

- Music generatorGenerates square waves of a different frequencies for each channel (A, B, and C).
- Noise generatorGenerates pseudo-random waveforms (variable frequency).
- Mixer.....Mixes 3-channels (A, B, and C) music and 1-channel noise generator output.
- Volume controlConstant level or variable level is given for each of the three channels (A, B, and C).
Constant levels are controlled by the CPU, and variable levels by the envelope generator.
- Envelope generatorGenerates various types of attenuation.
- D/A convertorOutputs mixed analog signal.

REGISTER ARRAY

ADDR	Function	D 7	D 6	D 5	D 4	D 3	D 2	D 1	D 0	
\$ 00	Channel A frequency	8 bit fine tone adjustment								
\$ 01						4 bit rough tone adjustment				
\$ 02	Channel B frequency	8 bit fine tone adjustment								
\$ 03						4 bit rough tone adjustment				
\$ 04	Channel C frequency	8 bit fine tone adjustment								
\$ 05						4 bit rough tone adjustment				
\$ 06	Noise frequency				5 bit noise frequency					
\$ 07	Mixer setting				Noise			Tone		
					C	B	A	C	B	A
\$ 08	Channel A level				M	L3	L2	L1	L0	
\$ 09	Channel B level				M	L3	L2	L1	L0	
\$ 0A	Channel C level				M	L3	L2	L1	L0	
\$ 0B	Envelope frequency	8 bit fine adjustment								
\$ 0C		8 bit rough adjustment								
\$ 0D	Envelope shape					CONT	ATT	ALT	HOLD	
\$ 0F	Control power	'0'	'0'	'0'	'0'					

Note) 1 : D7, D6, D5, and D4 bit of register \$0F must be '0'.

REGISTER FUNCTION

● Music frequency setting (\$00~\$05)

The frequency f_r of the square wave generated by each music generator (A, B, and C) is calculated by the following equation.

$$f_r = \frac{f_{Master}}{32TP}$$

	D7	D6	D5	D4	D3	D2	D1	D0
\$ 00 (CH-A)								
\$ 02 (CH-B)	TP7	TP6	TP5	TP4	TP3	TP2	TP1	TP0
\$ 04 (CH-C)								

	D7	D6	D5	D4	D3	D2	D1	D0
\$ 01 (CH-A)								
\$ 03 (CH-B)					TP11	TP10	TP9	TP8
\$ 05 (CH-C)								

f_{Master} is the frequency of master clock.

$$TP = TP11 * 2^{11} + TP10 * 2^{10} + TP9 * 2^9 + TP8 * 2^8 + TP7 * 2^7 + TP6 * 2^6 + TP5 * 2^5 + TP4 * 2^4 + TP3 * 2^3 + TP2 * 2^2 + TP1 * 2 + TP0$$

● Noise generator setting (\$06)

The noise frequency f_N is calculated by the following equation.

$$f_N = \frac{f_{Master}}{32NP}$$

	D7	D6	D5	D4	D3	D2	D1	D0
\$ 06				NP4	NP3	NP2	NP1	NP0

f_{Master} is the frequency of the master clock.

$$NP = NP4 * 2^4 + NP3 * 2^3 + NP2 * 2^2 + NP1 * 2 + NP0$$

● Mixer setting (\$07)

Setting '0' enables sound output. Mixed sound is output when both Noise and Tone outputs are set for the same channel.

	D7	D6	D5	D4	D3	D2	D1	D0
\$ 07			Noise			Tone		
			C	B	A	C	B	A

● Volume control and D/A convertor (\$08~\$0A)

The audio output level from the D/A convertors for the three channels (A, B, and C) is controlled as follows.
 When M=0, the output level is determined by the 4 bits of L3, L2, L1 and L0.

	D7	D6	D5	D4	D3	D2	D1	D0
\$ 08 (CH-A)								
\$ 09 (CH-B)				M	L3	L2	L1	L0
\$ 0A (CH-C)								

When M=1, the output level is determined by the 5 bits of E4, E3, E2, E1 and E0 of the envelope generator of the SSGL. (This output level is variable as E4~E0 change over time.)

When the maximum amplitude of the 5-bit D/A convertor is normalized to 1V, the output levels shown in Fig.1 are obtained.

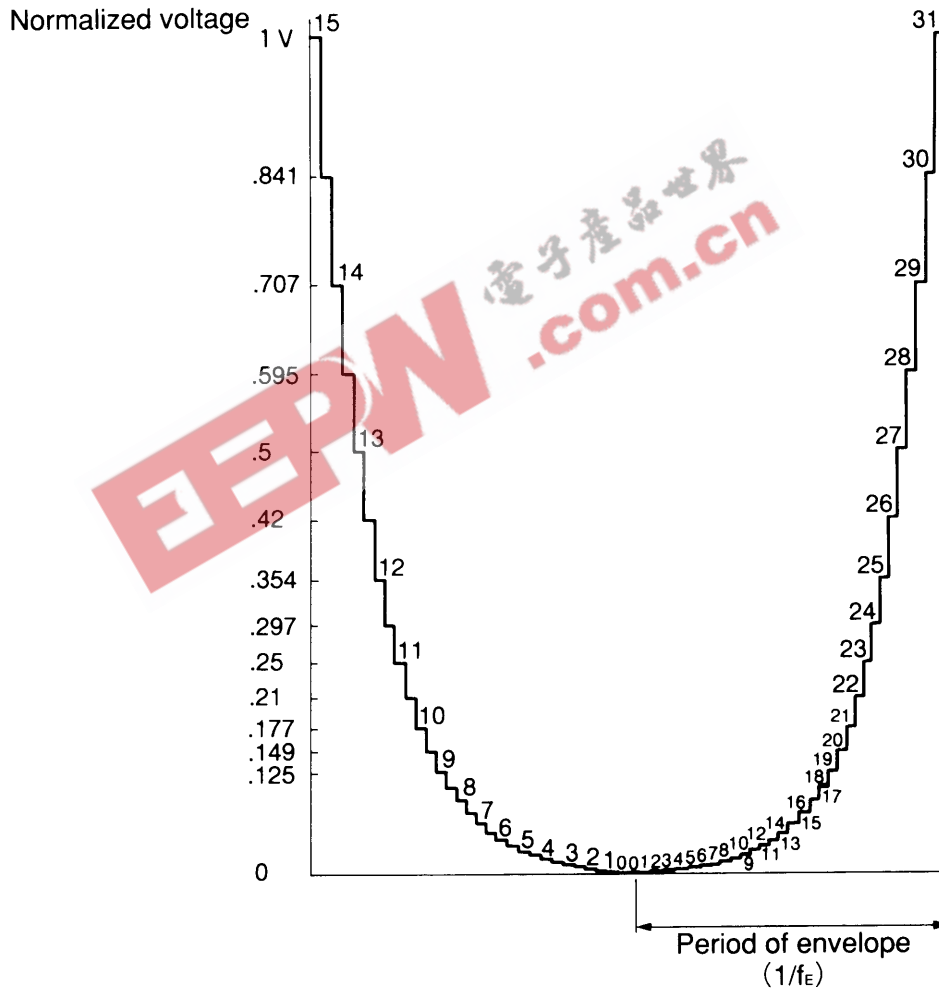

Fig.1 Output level of D/A convertor

The left half of the diagram shows fixed levels set by L3, L2, L1 and L0 bits.

The right half of the diagram shows output levels set by E4, E3, E2, E1 and E0 bits.

● Envelope frequency setting (\$0B~\$0C)

The envelope repetition frequency f_E is calculated by the following equation.

$$f_E = \frac{f_{Master}}{512EP}$$

f_{Master} is the frequency of the master clock.

$$EP = EP_{15} * 2^{15} + EP_{14} * 2^{14} + EP_{13} * 2^{13} + EP_{12} * 2^{12} + EP_{11} * 2^{11} + EP_{10} * 2^{10} + EP_9 * 2^9 + EP_8 * 2^8 + EP_7 * 2^7 + EP_6 * 2^6 + EP_5 * 2^5 + EP_4 * 2^4 + EP_3 * 2^3 + EP_2 * 2^2 + EP_1 * 2 + EP_0$$

The period of the actual frequency f_{EA} used for the envelope generated is 1/32 of the envelope repetition period ($1/f_E$).

\$0B	D7	D6	D5	D4	D3	D2	D1	D0
	EP7	EP6	EP5	EP4	EP3	EP2	EP1	EP0

\$0C	D7	D6	D5	D4	D3	D2	D1	D0
	EP15	EP14	EP13	EP12	EP11	EP10	EP9	EP8

● Envelope shape control (\$0D)

The envelope generator counts the envelope clock f_{EA} 32 times for each envelope pattern cycle. The envelope level is determined by the 5 bit output (E4~E0) of the counter.

\$0D	D7	D6	D5	D4	D3	D2	D1	D0
					CONT	ATT	ALT	HOLD

The shape of this envelope is created by increasing, decreasing, stopping, or repeating this counter.

Below envelope types are selected by CONT, ATT, ALT and HOLD setting.

D ₃	D ₂	D ₁	D ₀	Envelope shape
CONT	ATT	ALT	HOLD	
0	0	×	×	
0	1	×	×	
1	0	0	0	
1	0	0	1	
1	0	1	0	
1	0	1	1	
1	1	0	0	
1	1	0	1	
1	1	1	0	
1	1	1	1	

→ | 1 / f_E | ← Repetition period of envelope

EEPW.com.cn

■ ELECTRICAL CHARACTERISTICS

1. Absolute maximum ratings

Item	Symbol	Rating	Unit
Power supply voltage	V_{DD}	-0.3 ~ 7.0	V
Input voltage	V_I	$V_{SS}-0.3 \sim V_{DD}+0.3$	V
Storage temperature	T_{stg}	-50 ~ 125	°C

2. Recommended operating conditions

Item	Symbol	Min.	Typ.	Max.	Unit
Power supply voltage	V_{DD}	4.75	5	5.25	V
Operation temperature	T_{OP}	0	25	70	°C

3. DC Characteristics (Conditions : $T_a = 0 \sim 70 \text{ }^\circ\text{C}$, $V_{DD} = 5.0 \pm 0.25\text{V}$)

Item	Symbol	Condition	Min.	Typ.	Max.	Unit
Input highlevel voltage	V_{IH}	* 1	2.2			V
Input lowlevel voltage	V_{IL}	* 1			0.8	V
Input highlevel voltage	V_{IH}	* 2	3.5			V
Input lowlevel voltage	V_{IL}	* 2			1.0	V
Input leak current	I_{LI}	$V_I = 0 \sim 5\text{V}$, * 1	-10		10	μA
Pull-up resistance	R_U	* 2	60	250	600	$\text{k}\Omega$
Input capacity	C_I	* 3			10	pF
Power supply current	I_{DD}				10	mA

- Note) * 1 : Applied to all input pins except /IC.
 * 2 : Applied to /IC.
 * 3 : Applied to all input pins.

4. Analog Characteristics (Conditions : $T_a = 0 \sim 70 \text{ }^\circ\text{C}$, $V_{DD} = 5.0 \pm 0.25\text{V}$)

Item	Symbol	Condition	Min.	Typ.	Max.	Unit
Analog output voltage	V_{OA}	* 1	1.50	1.70	1.90	V

- Note) * 1 : Applied to SO pin. Maximum volume, $R_L = 1\text{k}\Omega$, peak to peak.

5. AC Characteristics (Conditions : Ta = 0~70°C, V_{DD} = 5.0±0.25V)

Item	Symbol	Min.	Typ.	Max.	Unit
Master clock frequency	f _c	1		4	MHz
Master clock duty	D	40		60	%
Master clock rise time	t _r			20	ns
Master clock fall time	t _f			20	ns
Reset pulse width	t _{icw}	5			μs
Address setup time	t _{AS}	20			ns
Address hold time	t _{AH}	10			ns
Chip select write width	t _{CSW}	30			ns
Write pulse write width	t _{WS}	0			ns
Write data hold time	t _{WH}	0			ns
Write data setup time (Address)	t _{WDSA}	10			ns
Write data setup time (Data)	t _{WDSD}	10			ns
Write data hold time (Address)	t _{WDHA}	10			ns
Write data hold time (Data)	t _{WDHD}	10			ns

6. Timing diagram

(1) Master clock timing

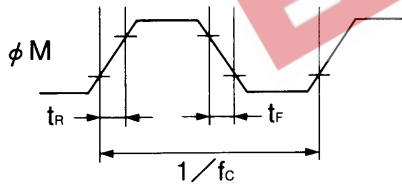

(2) Reset timing

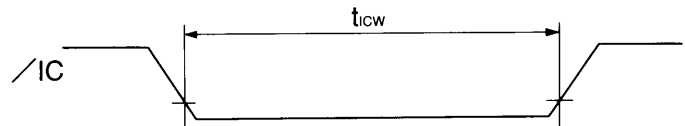

(3) CPU interface timing

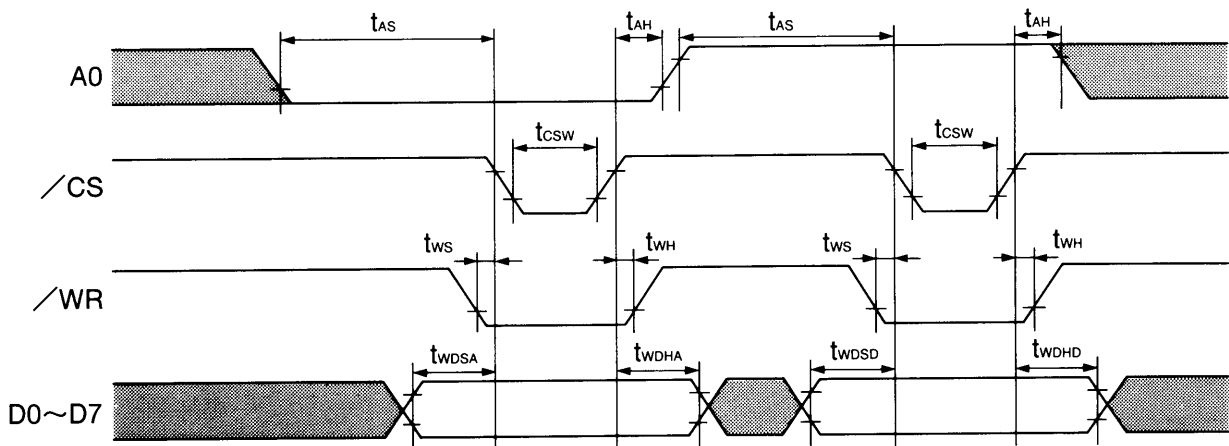

EXTERNAL DIMENSIONS

● YMZ284-D

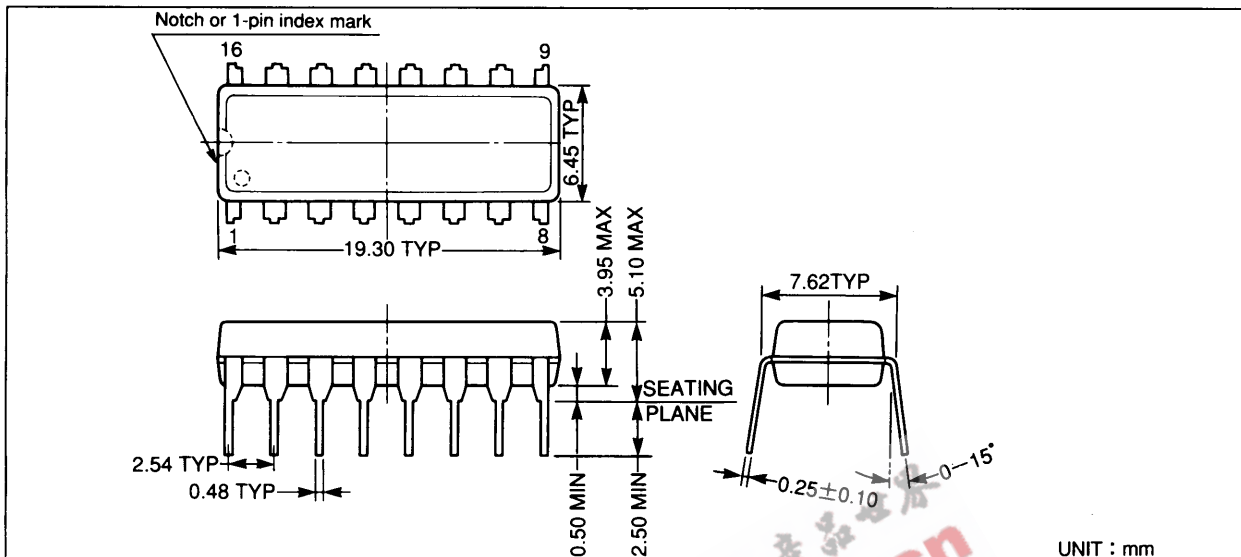

● YMZ284-M

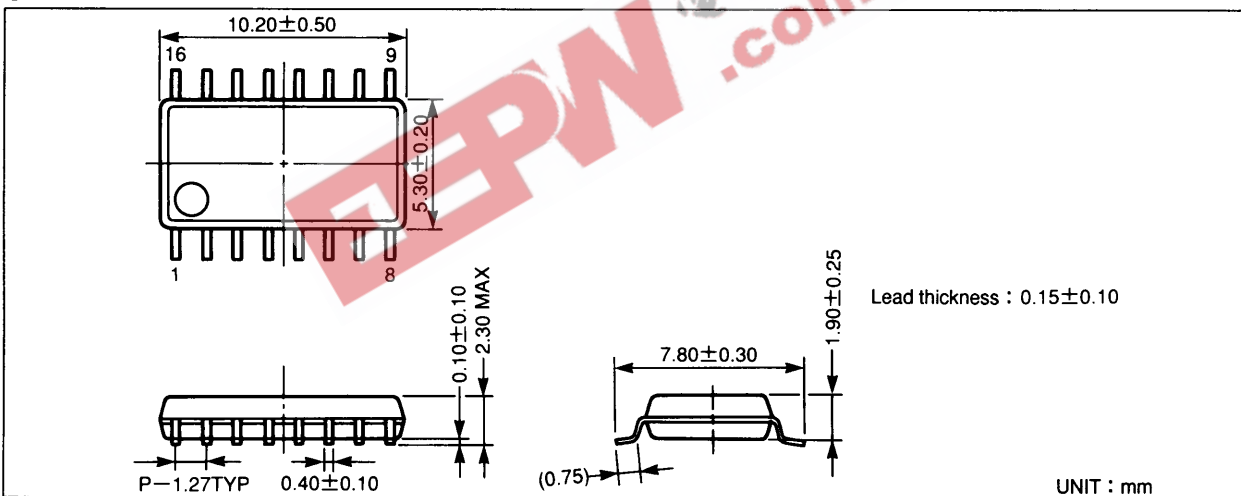

The specifications of this product are subject to improvement changes without prior notice.

IMPORTANT NOTICE

1. Yamaha reserves the right to make changes to its Products and to this document without notice. The information contained in this document has been carefully checked and is believed to be reliable. However, Yamaha assumes no responsibilities for inaccuracies and makes no commitment to update or to keep current the information contained in this document.

2. These Yamaha Products are designed only for commercial and normal industrial applications, and are not suitable for other uses, such as medical life support equipment, nuclear facilities, critical care equipment or any other application the failure of which could lead to death, personal injury or environmental or property damage. Use of the Products in any such application is at the customer's sole risk and expense.

3. YAMAHA ASSUMES NO LIABILITY FOR INCIDENTAL, CONSEQUENTIAL OR SPECIAL DAMAGES OR INJURY THAT MAY RESULT FROM MISAPPLICATION OR IMPROPER USE OR OPERATION OF THE PRODUCTS.

4. YAMAHA MAKES NO WARRANTY OR REPRESENTATION THAT THE PRODUCTS ARE SUBJECT TO INTELLECTUAL PROPERTY LICENSE FROM YAMAHA OR ANY THIRD PARTY, AND YAMAHA MAKES NO WARRANTY OR REPRESENTATION OF NON-INFRINGEMENT WITH RESPECT TO THE PRODUCTS. YAMAHA SPECIFICALLY EXCLUDES ANY LIABILITY TO THE CUSTOMER OR ANY THIRD PARTY ARISING FROM OR RELATED TO THE PRODUCTS' INFRINGEMENT OF ANY THIRD PARTY'S INTELLECTUAL PROPERTY RIGHTS, INCLUDING THE PATENT, COPYRIGHT, TRADEMARK OR TRADE SECRET RIGHTS OF ANY THIRD PARTY.

5. EXAMPLES OF USE DESCRIBED HEREIN ARE MERELY TO INDICATE THE CHARACTERISTICS AND PERFORMANCE OF YAMAHA PRODUCTS. YAMAHA ASSUMES NO RESPONSIBILITY FOR ANY INTELLECTUAL PROPERTY CLAIMS OR OTHER PROBLEMS THAT MAY RESULT FROM APPLICATIONS BASED ON THE EXAMPLES DESCRIBED HEREIN. YAMAHA MAKES NO WARRANTY WITH RESPECT TO THE PRODUCTS, EXPRESS OR IMPLIED, INCLUDING, BUT NOT LIMITED TO THE WARRANTIES OF MERCHANTABILITY, FITNESS FOR A PARTICULAR USE AND TITLE.

AGENCY**YAMAHA CORPORATION****Address inquiries to:****Semiconductor Sales & Marketing Department**

- Head Office 203, Matsunokijima, Toyooka-mura,
Iwata-gun, Shizuoka-ken, 438-0192
Tel. +81-539-62-4918 Fax. +81-539-62-5054
- Tokyo Office 2-17-11, Takanawa, Minato-ku,
Tokyo, 108-8568
Tel. +81-3-5488-5431 Fax. +81-3-5488-5088
- Osaka Office Namba Tsujimoto Nissei Bldg. 4F
1-13-17, Namba Naka, Naniwa-ku,
Osaka City, Osaka, 556-0011
Tel. +81-6-6633-3690 Fax. +81-6-6633-3691
- U.S.A. Office YAMAHA Systems Technology
100 Century Center Court, San Jose,
CA 95112
Tel. +1-408-467-2300 Fax. +1-408-437-8791