



Z89319/328

DIGITAL TELEVISION CONTROLLER IN-CIRCUIT EMULATOR (ICE) DEVICE

FEATURES

- | Part Number | ROM (Word) | RAM (Word) | Speed (MHz) |
|-------------|------------|------------|-------------|
| Z89319 | 0 | 0 | 12 |
| Z89328 | 0 | 0 | 12 |
- 0°C to +70°C Temperature Range
 - Direct Closed Caption Decoding
 - TV Tuner Serial Interface
 - Customized Character Set
 - Character Control Mode
 - Directly Controlled Receiver Functions
 - 124-Pin Grid Array (PGA) Package (Z89319)
100-Pin Quad Flat Pack (QFP) Package (Z89328)
 - 4.5- to 5.5-Volt Operating Range
 - Z89C00 RISC Processor Core

GENERAL DESCRIPTION

The Z89319 and Z89328 are ROMless versions of the Z89300 family of Zilog's Digital Television Controllers designed for use in emulators and development boards to provide complete audio and video control of television receivers, video recorders, and advanced on-screen display facilities.

The powerful Z89C00 RISC processor core allows users to control on-board peripheral functions and registers using the standard processor instruction set.

In closed caption mode, text can be decoded directly from the composite video signal and displayed on the screen with assistance from the processor's digital signal processing capabilities. The character representation in this mode allows for a simple attribute control through the insertion of control characters.

The character control mode provides access to the full set of attribute controls. The modification of attributes is allowed on a character-by-character basis. The insertion of control characters permits direction of other character attributes.

Display attributes, including underlining, italics, blinking, eight foreground/background colors, character position offset delay, and background transparency, are made possible through a fully customized 512 character set, formatted in two 256 character banks.

Serial interfacing with the television tuner is provided through the tuner serial port. Digital channel tuning adjustments may be accessed through the industry-standard I²C port.

Additional hardware provides the capability to display two to three times normal size characters. The smoothing logic contained in the on-screen display circuit improves the appearance of larger fonts. Special circuitry can be activated to improve the visibility of text by adding a right-sided shadow effect to the characters.

Receiver functions such as color and volume can be directly controlled by six 8-bit pulse width modulated ports.

Notes:

All Signals with a preceding front slash, "/", are active Low, e.g.: B/W (WORD is active Low); /B/W (BYTE is active Low, only).

Power connections follow conventional descriptions below:

Connection	Circuit	Device
Power	V _{CC}	V _{DD}
Ground	GND	V _{SS}

GENERAL DESCRIPTION (Continued)

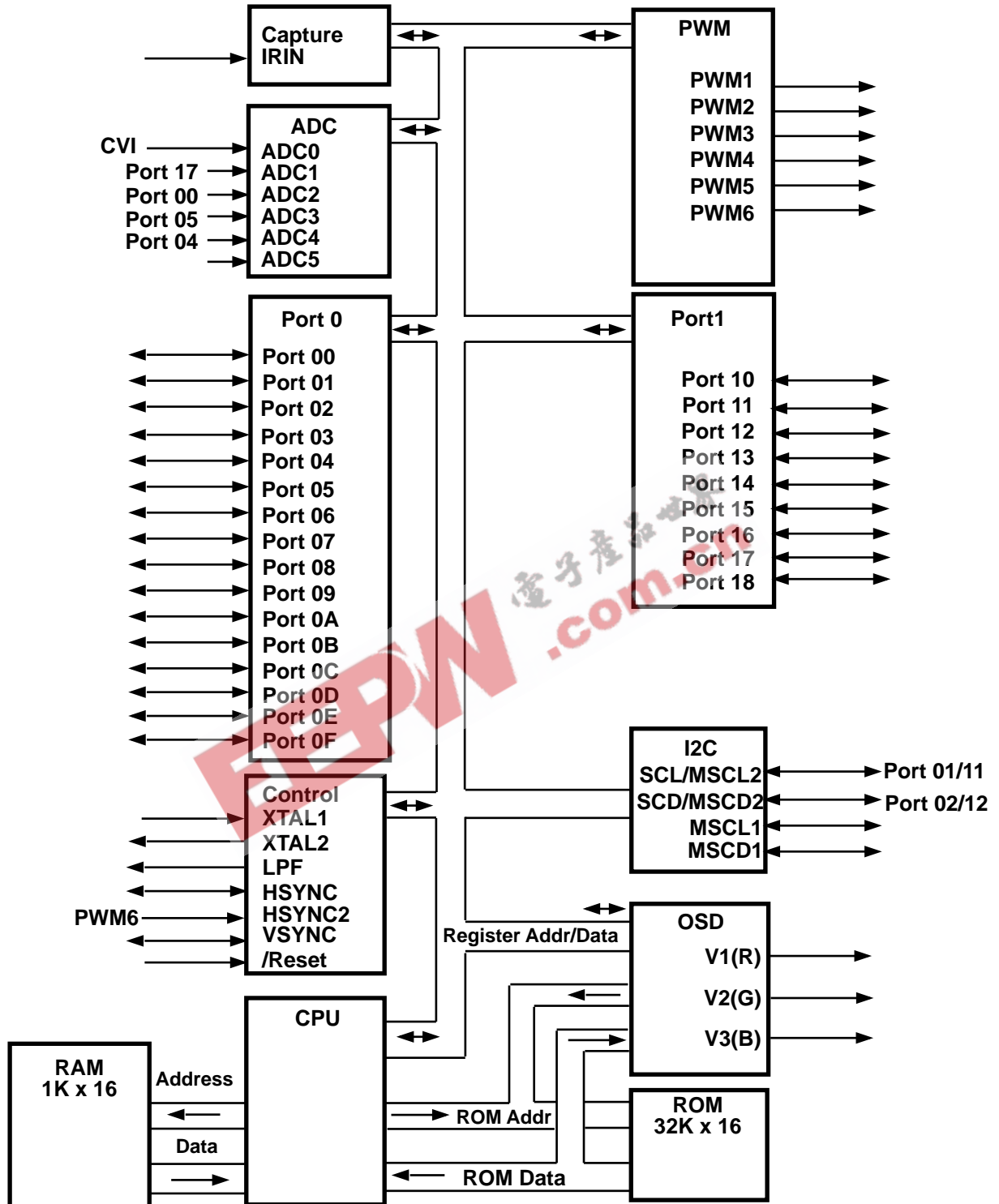

Functional Block Diagram