

# Z86C83/C84

## Z8<sup>®</sup> MCU MICROCONTROLLERS

### FEATURES

Device	ROM (KB)	RAM* (Bytes)	I/O Lines	Voltage Range
Z86C83	4	237	21	3.0V to 5.5V
Z86C84	4	237	17	3.0V to 5.5V

**Note:** \* General-Purpose

- 28-Pin DIP, SOIC, and PLCC Packages
- Clock Speed: 16 MHz
- Three Expanded Register Groups
- 8-Channel, 8-Bit A/D Converter with Track and Hold, and Unique R-Ladder  $A_{GND}$  Offset Control
- Z86C84 has two 8-Bit D/A Converters with Programmable Gain Stages, 3  $\mu$ s Settling Time
- Six Vectored, Prioritized Interrupts from Six Different Sources
- Two Analog Comparator Inputs with Programmable Interrupt Polarity
- Two Programmable 8-Bit Timers, each with a 6-Bit Programmable Prescaler
- Auto Latch Mask Option for P00, P01, and P02
- Power-On Reset (POR) Timer
- Permanent Watch-Dog Timer (WDT) Mask Option
- Software-Programmable Pull-Up Resistors
- On-Chip Oscillator for Crystal, Resonator or LC

### GENERAL DESCRIPTION

The Z86C83/C84 Consumer Controller Processors (CCP™) are full-featured members of the CMOS Z8 micro-controller family offering a unique register-to-register architecture that avoids accumulator bottlenecks for higher code efficiency than RISC processors.

The Z86C83/C84 are designed to be used in a wide variety of embedded control applications, such as appliances, process controls, keyboards, security systems, battery chargers, and automotive modules.

For applications requiring powerful I/O capabilities, the Z86C83/C84 devices can have up to 21/17 (C83/C84 respectively) pins dedicated to input and output. These lines are grouped into three ports, and are configured by software to provide digital/analog I/O timing and status signals.

An on-chip, half-flash 8-bit  $\pm 1/2$  Least Significant Bit (LSB) A/D converter can multiplex up to eight analog inputs.

Unused analog inputs revert to standard digital I/O use. Unique, programmable  $A_{GND}$  offset control of the A/D resistor ladder compresses the converter's dynamic range for maximum effective 9-bit A/D resolution.

The Z86C84 has two 8-bit  $\pm 1/2$  LSB D/A converters. High and low reference voltages provide precise control of the output voltage range. Programmable gain for each D/A converter provides a maximum effective 10-bit resolution for many tasks.

On-chip 8-bit counter/timers with many user-selectable modes simplify real-time tasks, such as counting, timing, and generation of PWM signals.

The designer can prioritize six different maskable, vectored, internal or external interrupts for efficient interrupt handling and multitasking functions.

## GENERAL DESCRIPTION (Continued)

By means of an expanded register file, the designer has access to additional control registers for configuring peripheral functions including the A/D and D/A converters, counter/timers, and I/O port functions (Figure 1).

**Notes:** All Signals with a preceding front slash, "/", are active Low, e.g., B/W (WORD is active Low); /B/W (BYTE is active Low, only).

Power connections follow conventional descriptions below:

Connection	Circuit	Device
Power	V <sub>CC</sub>	V <sub>CC</sub>
Ground	GND	V <sub>SS</sub>

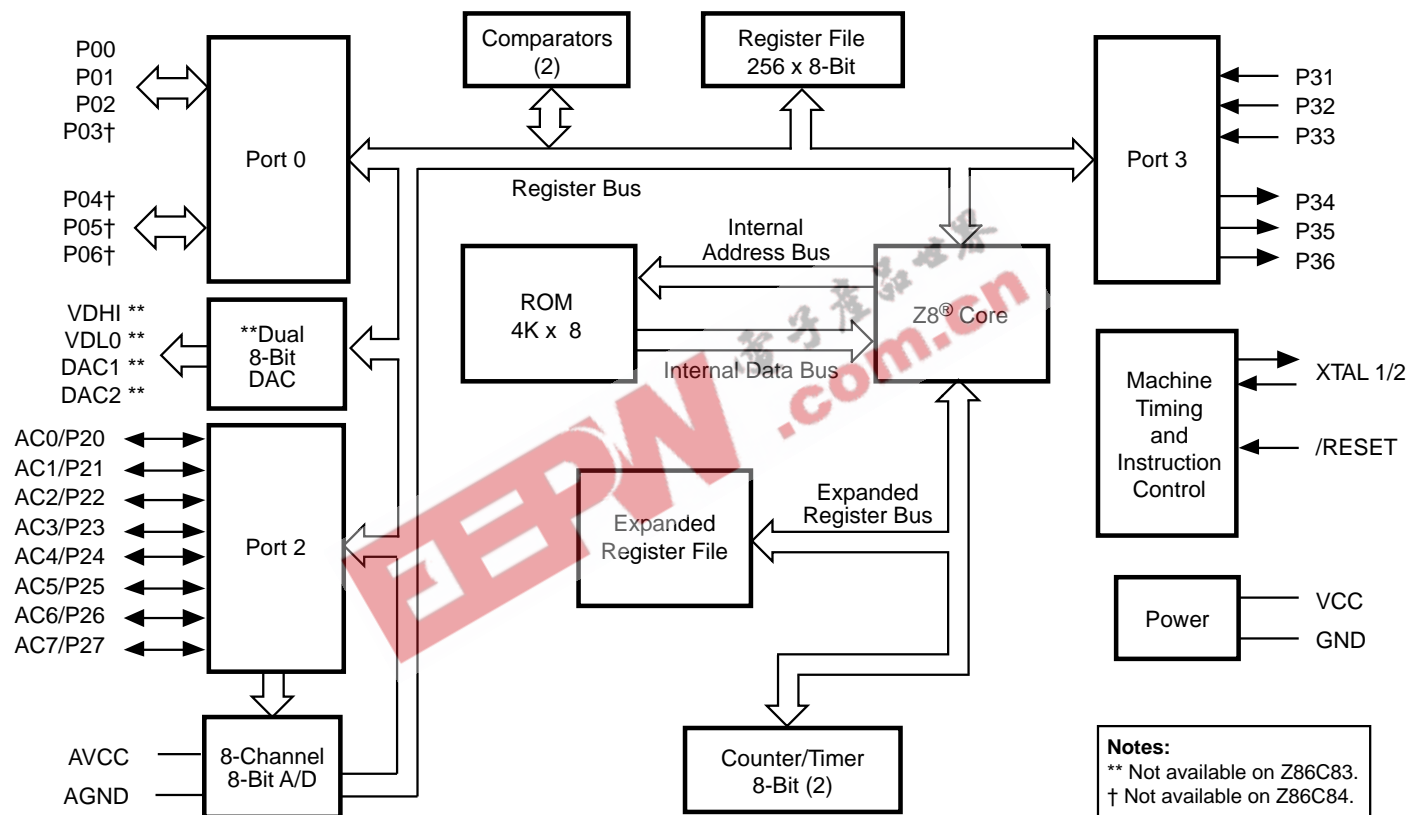

Figure 1. Z86C83/C84 Functional Block Diagram

**PIN DESCRIPTION**

**Table 1. Z86C83 28-Pin DIP, SOIC Pin Identification\***

No	Symbol	Function	Direction
1-7	P21-P27 or AC1-AC7	Port 2, Bit 1-7 Analog In 1-7	Input/Output
8	/RESET	Reset	Input
9	XTAL1	Oscillator Clock	Input
10	XTAL2	Oscillator Clock	Output
11	GND	Ground	
12	V <sub>CC</sub>	Power	
13-15	P31-P33	Port 3, Bits 1-3	Input
16	P34	Port 3, Bit 4	Output
17	P36	Port 3, Bit 6	Output
18	P35	Port 3, Bit 5	Output
19-25	P0-P06	Port 0, Bits 0-6	Input/Output
26	A <sub>GND</sub>	Analog Ground	
27	AV <sub>CC</sub>	Analog Power	
28	P20 or AC0	Port 2, Bit 0 Analog In 0	Input/Output

**Note:**

\* DIP and SOIC Pin Description and Configuration are identical.

**Table 2. Z86C84 28-Pin DIP, SOIC Pin Identification\***

No	Symbol	Function	Direction
1-7	P21-P27 or AC1-AC7	Port 2, Bit 1-7 Analog In 1-7	Input/Output
8	/RESET	Reset	Input
9	XTAL1	Oscillator Clock	Input
10	XTAL2	Oscillator Clock	Output
11	GND	Ground	
12	V <sub>CC</sub>	Power	
13-15	P31-P33	Port 3, Bits 1-3	Input
16	P34	Port 3, Bit 4	Output
17	P36	Port 3, Bit 6	Output
18	P35	Port 3, Bit 5	Output
19-21	P0-P02	Port 0, Bits 0-3	Input/Output
22	VDLO	D/A Ref. Volt.,Low	Input
23	VDHI	D/A Ref. Volt.,High	Input
24-25	DAC2-1	D/A Converter	Output
26	A <sub>GND</sub>	Analog Ground	
27	AV <sub>CC</sub>	Analog Power	
28	P20 or AC0	Port 2, Bit 0 Analog In 0	Input/Output

**Note:**

\* DIP and SOIC Pin Description and Configuration are identical

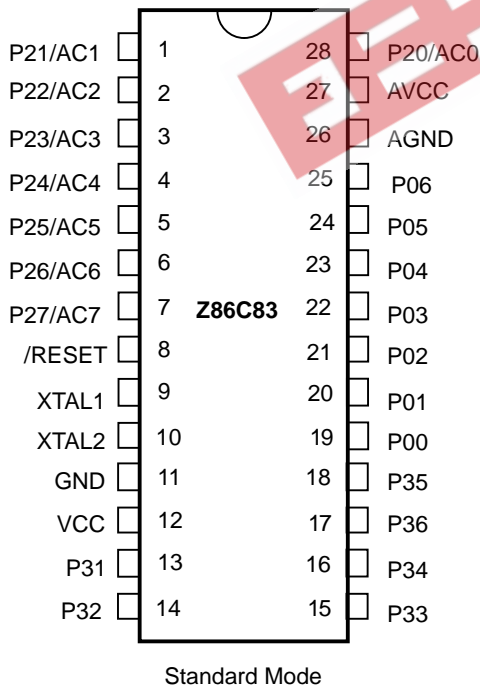

**Figure 2. Z86C83 28-Pin DIP and SOIC Pin Configuration\***

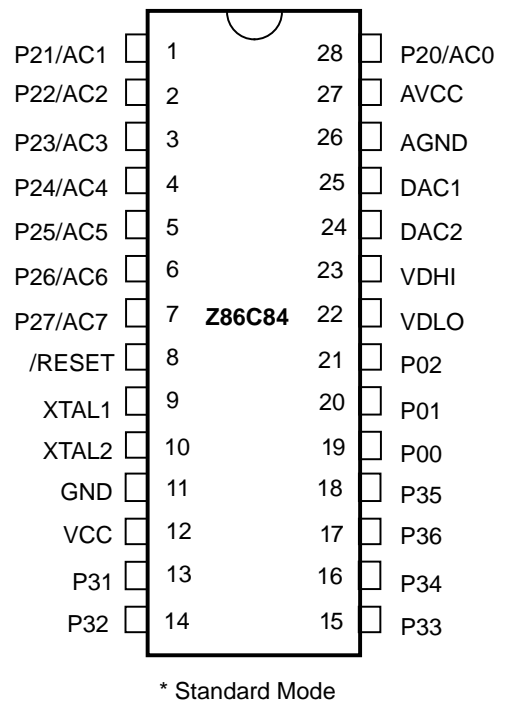

**Figure 3. Z86C84 28-Pin DIP and SOIC Pin Configuration\***

**PIN DESCRIPTION (Continued)**

**Table 3. Z86C83 28-Pin PLCC Pin Identification**

No	Symbol	Function	Direction
1-8	P20-P27 or AC0-AC7	Port 2, Bit 0-7 Analog In 0-7	Input/Output
9	/RESET	Reset	Input
10	XTAL1	Oscillator Clock	Input
11	XTAL2	Oscillator Clock	Output
12	GND	Ground	
13	V <sub>CC</sub>	Power	
14-16	P31-P33	Port 3, Bits 1-3	Input
17	P34	Port 3, Bit 4	Output
18	P36	Port 3, Bit 6	Output
19	P35	Port 3, Bit 5	Output
20-26	P00-P06	Port 0, Bits 0-6	Input/Output
27	A <sub>GND</sub>	Analog Ground	
28	AV <sub>CC</sub>	Analog Power	

**Table 4. Z86C84 28-Pin PLCC Pin Identification**

No	Symbol	Function	Direction
1-8	P20-P27 or AC0-AC7	Port 2, Bit 0-7 Analog In 0-7	Input/Output
9	/RESET	Reset	Input
10	XTAL1	Oscillator Clock	Input
11	XTAL2	Oscillator Clock	Output
12	GND	Ground	
13	V <sub>CC</sub>	Power	
14-16	P31-P33	Port 3, Bits 1-3	Input
17	P34	Port 3, Bit 4	Output
18	P36	Port 3, Bit 6	Output
19	P35	Port 3, Bit 5	Output
20-22	P00-P02	Port 0, Bits 0-3	Input/Output
23	VDLO	D/A Ref. Volt.,Low	Input
24	VDHI	D/A Ref. Volt.,High	Input/Output
25-26	DAC2-DAC1	D/A Converter	Output
27	A <sub>GND</sub>	Analog Ground	
28	AV <sub>CC</sub>	Analog Power	

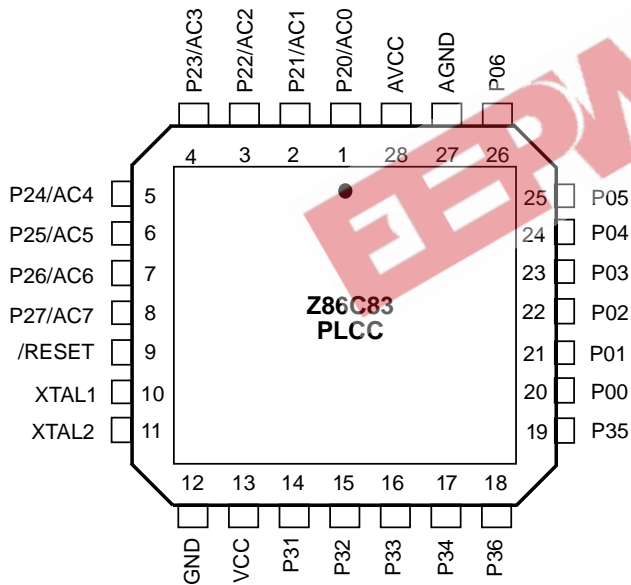

**Figure 4. Z86C83 28-Pin PLCC Pin Configuration**

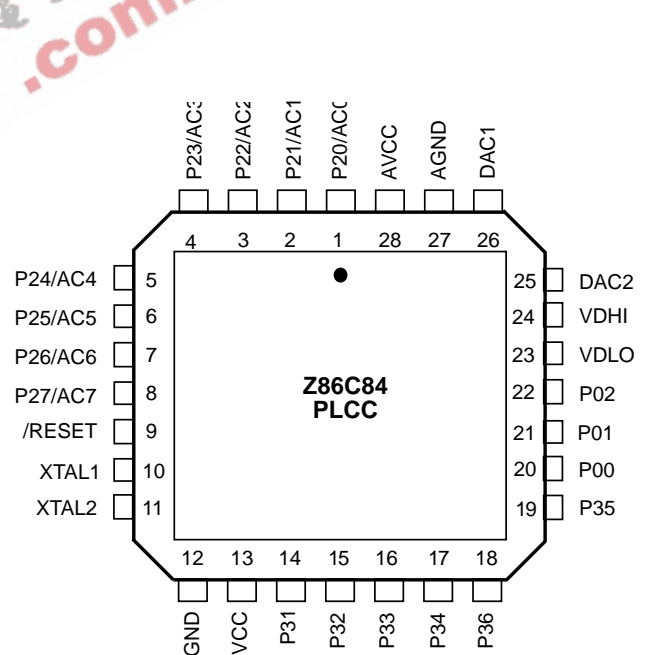

**Figure 5. Z86C84 28-Pin PLCC Pin Configuration**

## ABSOLUTE MAXIMUM RATINGS

Parameter	Min	Max	Units
Ambient Temperature under Bias	-40	+105	C
Storage Temperature	-65	+150	C
Voltage on any Pin with Respect to $V_{SS}$ [Note 1]	-0.6	+7	V
Voltage on $V_{CC}$ Pin with Respect to $V_{SS}$	-0.3	+7	V
Voltage on /RESET Pins with Respect to $V_{SS}$ [Note 2]	-0.6	$V_{CC}+1$	V
Total Power Dissipation		770	mW
Maximum Current out of $V_{SS}$		140	mA
Maximum Current into $V_{CC}$		125	mA
Maximum Current into an Input Pin [Note 3]	-600	+600	$\mu$ A
Maximum Current into an Open-Drain Pin [Note 4]	-600	+600	$\mu$ A
Maximum Output Current Sunked by Any I/O Pin		25	mA
Maximum Output Current Sourced by Any I/O Pin		25	mA

### Notes:

1. This applies to all pins except XTAL and /RESET pins and where otherwise noted.
2. There is no input protection diode from pin to  $V_{CC}$ .
3. This excludes XTAL pins.
4. Device pin is not at an output Low state.

### Notice:

Stresses greater than those listed under Absolute Maximum Ratings may cause permanent damage to the device. This is a stress rating only; functional operation of the device at any condition above those indicated in the operational sections of these specifications is not implied. Exposure to absolute maximum rating conditions for an extended period may affect device reliability.

Total power dissipation should not exceed 770 mW for the package. Power dissipation is calculated as follows:

$$\text{Total Power Dissipation} = V_{CC} \times [I_{CC} - (\text{sum of } I_{OH})] + \text{sum of } [(V_{CC} - V_{OH}) \times I_{OH}] + \text{sum of } (V_{OL} \times I_{OL})$$

## STANDARD TEST CONDITIONS

The characteristics listed below apply for standard test conditions as noted. All voltages are referenced to Ground. Positive current flows into the referenced pin (Figure 6).

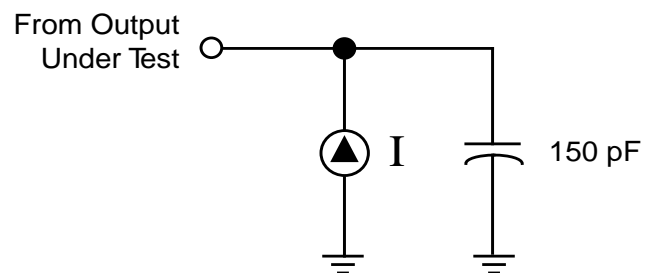

Figure 6. Test Load Diagram

## $V_{DD}$ SPECIFICATION

$V_{DD} = 3.0V$  to  $5.5V$

## CAPACITANCE

$T_A = 25^\circ\text{C}$ ,  $V_{CC} = \text{GND} = 0\text{V}$ ,  $f = 1.0\text{ MHz}$ , unmeasured pins returned to GND.

Parameter	Min	Max
Input capacitance	0	20 pF
Output capacitance	0	20pF
I/O capacitance	0	20 pF

EEPW 电子产品世界  
.com.cn

**DC ELECTRICAL CHARACTERISTICS**

Sym	Parameter	V <sub>CC</sub> Note 3	T <sub>A</sub> = 0° C to +70° C		T <sub>A</sub> = -40° C to +105° C		Typical [13] @ 25° C	Units	Conditions	Notes
			Min	Max	Min	Max				
V <sub>CH</sub>	Clock Input High Voltage	3.0V	0.7 V <sub>CC</sub>	V <sub>CC</sub> +0.3	0.7 V <sub>CC</sub>	V <sub>CC</sub> +0.3	1.3	V	Driven by External Clock Generator	
		5.5V	0.7 V <sub>CC</sub>	V <sub>CC</sub> +0.3	0.7 V <sub>CC</sub>	V <sub>CC</sub> +0.3	2.5	V	Driven by External Clock Generator	
V <sub>CL</sub>	Clock Input Low Voltage	3.0V	GND-0.3	0.2 V <sub>CC</sub>	GND-0.3	0.2 V <sub>CC</sub>	0.7	V	Driven by External Clock Generator	
		5.5V	GND-0.3	0.2 V <sub>CC</sub>	GND-0.3	0.2 V <sub>CC</sub>	1.5	V	Driven by External Clock Generator	
V <sub>IH</sub>	Input High Voltage	3.0V	0.7 V <sub>CC</sub>	V <sub>CC</sub> +0.3	0.7 V <sub>CC</sub>	V <sub>CC</sub> +0.3	1.3	V		
		5.5V	0.7 V <sub>CC</sub>	V <sub>CC</sub> +0.3	0.7 V <sub>CC</sub>	V <sub>CC</sub> +0.3	2.5	V		
V <sub>IL</sub>	Input Low Voltage	3.0V	GND-0.3	0.2 V <sub>CC</sub>	GND-0.3	0.2 V <sub>CC</sub>	0.7	V		
		5.5V	GND-0.3	0.2 V <sub>CC</sub>	GND-0.3	0.2 V <sub>CC</sub>	1.5	V		
V <sub>OH1</sub>	Output High Voltage	3.0V	V <sub>CC</sub> -0.4		V <sub>CC</sub> -0.4		3.1	V	I <sub>OH</sub> = -2.0 mA	8
		5.5V	V <sub>CC</sub> -0.4		V <sub>CC</sub> -0.4		4.8	V	I <sub>OH</sub> = -2.0 mA	8
V <sub>OL1</sub>	Output Low Voltage	3.0V		0.6		0.6	0.2	V	I <sub>OL</sub> = +4.0 mA	8
		5.5V		0.4		0.4	0.1	V	I <sub>OL</sub> = +4.0 mA	8
V <sub>OL2</sub>	Output Low Voltage	3.0V		1.2		1.2	0.3	V	I <sub>OL</sub> = +6 mA	8
		5.5V		1.2		1.2	0.3	V	I <sub>OL</sub> = +12 mA	8
V <sub>RH</sub>	Reset Input High Voltage	3.0V	.8 V <sub>CC</sub>	V <sub>CC</sub>	.8 V <sub>CC</sub>	V <sub>CC</sub>	1.5	V		
		5.5V	.8 V <sub>CC</sub>	V <sub>CC</sub>	.8 V <sub>CC</sub>	V <sub>CC</sub>	2.1	V		
V <sub>RI</sub>	Reset Input Low Voltage	3.0V	GND-0.3	0.2 V <sub>CC</sub>	GND-0.3	0.2 V <sub>CC</sub>	1.1	V		
		5.5V	GND-0.3	0.2 V <sub>CC</sub>	GND-0.3	0.2 V <sub>CC</sub>	1.7	V		
V <sub>OFFSET</sub>	Comparator Input Offset Voltage	3.0V		25		25	10	mV		10
		5.5V		25		25	10	mV		10
I <sub>IL</sub>	Input Leakage	3.0V	-1	1	-1	2	<1	μA	V <sub>IN</sub> = 0V, V <sub>CC</sub>	
		5.5V	-1	1	-1	2	<1	μA	V <sub>IN</sub> = 0V, V <sub>CC</sub>	
I <sub>OL</sub>	Output Leakage	3.0V	-1	1	-1	2	<1	μA	V <sub>IN</sub> = 0V, V <sub>CC</sub>	
		5.5V	-1	1	-1	2	<1	μA	V <sub>IN</sub> = 0V, V <sub>CC</sub>	
I <sub>IR</sub>	Reset Input Current	3.0V		-130		-130	-25	μA		
		5.5V		-180		-180	-40	μA		
I <sub>CC</sub>	Supply Current	3.0V		20		20	7	mA	@ 16 MHz	4, 15
		5.5V		25		25	20	mA	@ 16 MHz	4, 15
		5.0V		7		7	3	mA	@ 3.58 MHz	4, 15
		5.0V		10		10	5	mA	@ 8 MHz	4, 15
I <sub>CC1</sub>	Standby Current	3.0V		4.5		4.5	2.0	mA	HALT Mode V <sub>IN</sub> = 0V, V <sub>CC</sub> @ 16 MHz	4
		5.5V		8		8	3.7	mA	HALT Mode V <sub>IN</sub> = 0V, V <sub>CC</sub> @ 16 MHz	4
		3.0V		3.4		3.4	1.5	mA	Clock Divide-by-16 @ 16 MHz	4
		5.5V		7.0		7.0	2.9	mA	Clock Divide-by-16 @ 16 MHz	4

Sym	Parameter	V <sub>CC</sub> Note 3	T <sub>A</sub> = 0° C to +70° C		T <sub>A</sub> = -40° C to +105° C		Typical [13] @ 25° C	Units	Conditions	Notes
			Min	Max	Min	Max				
I <sub>CC2</sub>	Standby Current	3.0V		8		15	1	μA	STOP Mode V <sub>IN</sub> = OV, V <sub>CC</sub> WDT is not Running	6,11,15
		5.5V		10		20	2	μA	STOP Mode V <sub>IN</sub> = OV, V <sub>CC</sub> WDT is not Running	6,11,15
		3.0V		500		600	310	μA	STOP Mode V <sub>IN</sub> = OV, V <sub>CC</sub> WDT is Running	6,11,14, 15
		5.5V		800		1000	600	μA	STOP Mode V <sub>IN</sub> = OV, V <sub>CC</sub> WDT is Running	6,11,14, 15
V <sub>ICR</sub>	Input Common Mode	3.0	0	V <sub>CC</sub> -1.0V	0	V <sub>CC</sub> -1.5V		V		10
	Voltage Range	5.5	0	V <sub>CC</sub> -1.0V	0	V <sub>CC</sub> -1.5V		V		10
I <sub>ALL</sub>	Auto Latch Low Current	3.0V		8		10	5	μA	OV < V <sub>IN</sub> < V <sub>CC</sub>	9
		5.5V		15		20	11	μA	OV < V <sub>IN</sub> < V <sub>CC</sub>	9
I <sub>ALH</sub>	Auto Latch High Current	3.0V		-5		-7	-3	μA	OV < V <sub>IN</sub> < V <sub>CC</sub>	9
		5.5V		-8		-10	-6	μA	OV < V <sub>IN</sub> < V <sub>CC</sub>	9
V <sub>LV</sub>	V <sub>CC</sub> Low-Voltage Protection Voltage		2.0	3.3	2.2	3.6	3.0	V	2 MHz max Int. CLK Freq.	7

Notes:

- I<sub>CC1</sub> Clock-Driven Typical 0.3 mA Max 5 Unit mA Freq 8 MHz
- GND = 0V.
- 3.0V V<sub>CC</sub> voltage specification guarantees 3.3V ±0.3V, and 5.5V V<sub>CC</sub> voltage specification guarantees 5.0V ±0.5V.
- All outputs unloaded, I/O pins floating, inputs at rail.
- CL1 = CL2 = 100 pF.
- Same as note [4] except inputs at V<sub>CC</sub>.
- The V<sub>LV</sub> increases as the temperature decreases.
- Standard Mode (not Low EMI).
- Auto Latch (mask option) selected.
- For analog comparator, inputs when analog comparators are enabled.
- Clock must be forced Low, when XTAL 1 is clock-driven and XTAL2 is floating.
- Excludes clock pins.
- Typicals are at V<sub>CC</sub> = 5.0V and 3.3V.
- Internal RC selected.
- Combined Digital and Analog V<sub>CC</sub> supply current.



## AC ELECTRICAL CHARACTERISTICS

### Additional Timing Diagram

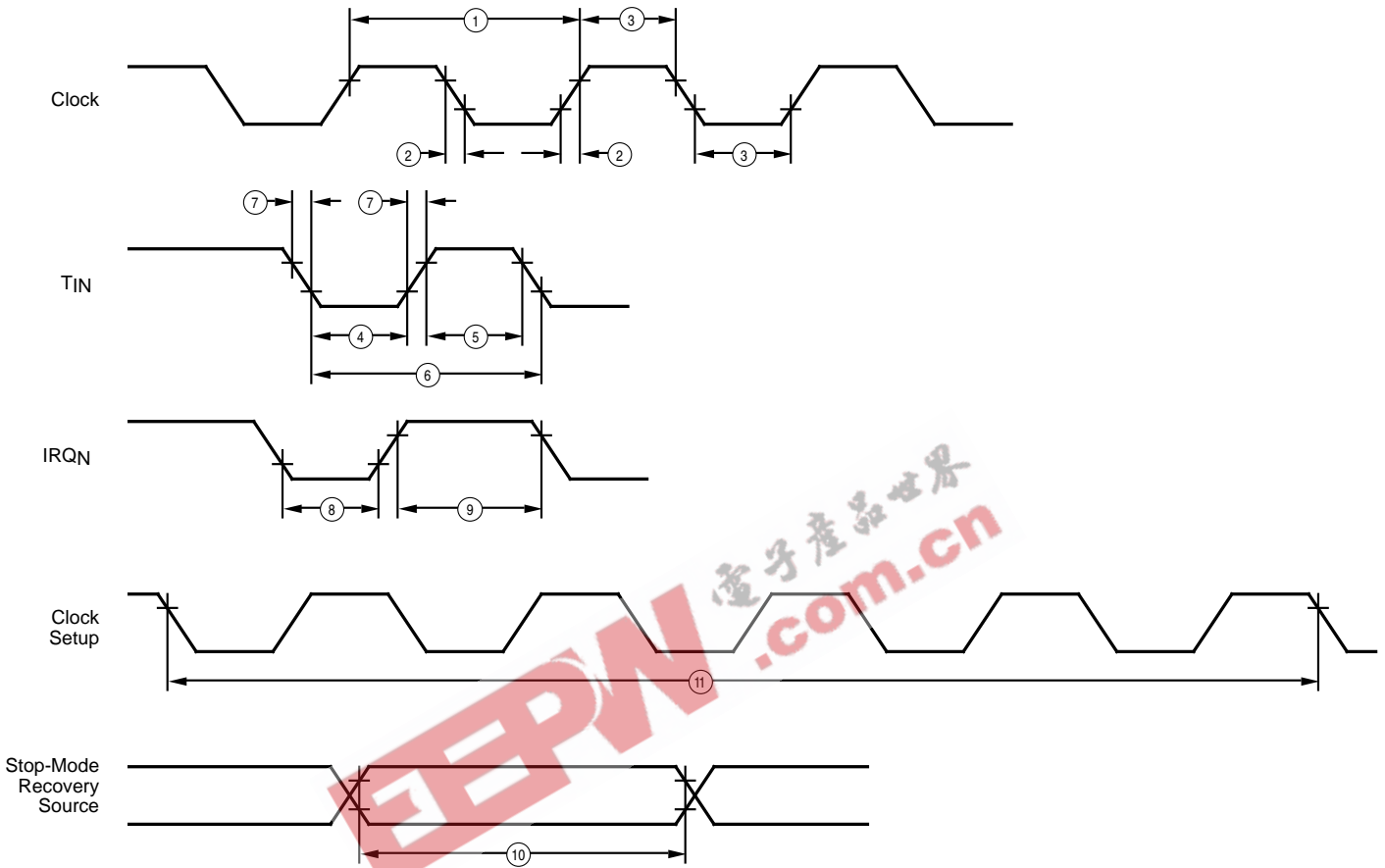

Figure 7. Additional Timing

## AC ELECTRICAL CHARACTERISTICS (Continued)

Additional Timing Table (SCLK/TCLK = XTAL/2)

No	Symbol	Parameter	V <sub>cc</sub> Note 6	T <sub>A</sub> = 0°C to +70°C				T <sub>A</sub> = -40°C to +105°C				Units	Notes	
				12 MHz Min	12 MHz Max	16 MHz Min	16 MHz Max	12 MHz Min	12 MHz Max	16 MHz Min	16 MHz Max			
1	TpC	Input Clock Period	3.0V	83	DC	62.5	DC	83	DC	62.5	DC	ns	1	
			5.5V	83	DC	62.5	DC	83	DC	62.5	DC	ns	1	
2	TrC,TfC	Clock Input Rise & Fall Times	3.0V		15		15		15		15	ns	1	
			5.5V		15		15		15		15	ns	1	
3	TwC	Input Clock Width	3.0V	41		31		41		31		ns	1	
			5.5V	41		31		41		31		ns	1	
4	TwTinL	Timer Input Low Width	3.0V	100		100		100		100		ns	1	
			5.5V	70		70		70		70		ns	1	
5	TwTinH	Timer Input High Width	3.0V	5TpC		5TpC		5TpC		5TpC			1	
			5.5V	5TpC		5TpC		5TpC		5TpC			1	
6	TpTin	Timer Input Period	3.0V	8TpC		8TpC		8TpC		8TpC			1	
			5.5V	8TpC		8TpC		8TpC		8TpC			1	
7	TrTin, TfTin	Timer Input Rise & Fall Timer	3.0V		100		100		100		100	ns	1	
			5.5V		100		100		100		100	ns	1	
8A	TwIL	Int. Request Low Time	3.0V	100		100		100		100		ns	1,2	
			5.5V	70		70		70		70		ns	1,2	
8B	TwIL	Int. Request Low Time	3.0V	5TpC		5TpC		5TpC		5TpC			1,3	
			5.5V	5TpC		5TpC		5TpC		5TpC			1,3	
9	TWH	Int. Request Input High Time	3.0V	5TpC		5TpC		5TpC		5TpC			1,2	
			5.5V	5TpC		5TpC		5TpC		5TpC			1,2	
10	TwsM	STOP-Mode Recovery Width Spec	3.0V	12		12		12		12		ns		
			5.5V	12		12		12		12		ns		
11	Tost	Oscillator Startup Time	3.0V		5TpC		5TpC		5TpC		5TpC		4	
			5.5V		5TpC		5TpC		5TpC		5TpC		4	
12	Twdt	Watch-Dog Timer Delay Time									WDTMR	Reg.	D1	D0
			3.0V	6.25		6.25		6.25		6.25		ms	0	0
			3.0V	12.5		12.5		12.5		12.5		ms	0	1
			3.0V	25		25		25		25		ms	1	0
			3.0V	100		100		100		100		ms	1	1
13	T <sub>POR</sub>	Power On Reset Delay	3.0V	7	24	7	25	7	24	7	25	ms		
			5.5V	3	13	3	14	3	13	3	14	ms		

### Notes:

1. Timing Reference uses 0.7 V<sub>cc</sub> for a logic 1 and 0.2 V<sub>cc</sub> for a logic 0.
2. Interrupt request via Port 3 (P31-P33).
3. Interrupt request via Port 3 (P30).
4. SMR-D5 = 0.
5. The V<sub>cc</sub> voltage specification of 3.0V guarantees 3.3V ±0.3V, and the V<sub>cc</sub> voltage specification of 5.5V guarantees 5.0V ±0.5V.

## AC ELECTRICAL CHARACTERISTICS (Continued)

Additional Timing Table (Divide-By-One Mode, SCLK/TCLK = XTAL)

No	Symbol	Parameter	V <sub>cc</sub> Note 6	T <sub>A</sub> = 0°C to +70°C		T <sub>A</sub> = -40°C to +105°C		Units	Notes
				4 MHz		4 MHz			
				Min	Max	Min	Max		
1	TpC	Input Clock Period	3.0V	250	DC	250	DC	ns	1,7,8
			5.5V	250	DC	250	DC	ns	1,7,8
2	TrC, TfC	Clock Input Rise & Fall Times	3.0V		25		25	ns	1,7,8
			5.5V		25		25	ns	1,7,8
3	TwC	Input Clock Width	3.0V	125		125		ns	1,7,8
			5.5V	125		125		ns	1,7,8
4	TwTinL	Timer Input Low Width	3.0V	100		100		ns	1,7,8
			5.5V	70		70		ns	1,7,8
5	TwTinH	Timer Input High Width	3.0V	3TpC		3TpC			1,7,8
			5.5V	3TpC		3TpC			1,7,8
6	TpTin	Timer Input Period	3.0V	4TpC		4TpC			1,7,8
			5.5V	4TpC		4TpC			1,7,8
7	TrTin, TfTin	Timer Input Rise & Fall Timer	3.0V		100		100	ns	1,7,8
			5.5V		100		100	ns	1,7,8
8A	TwIL	Int. Request Low Time	3.0V	100		100		ns	1,2,7,8
			5.5V	70		70		ns	1,2,7,8
8B	TwIL	Int. Request Low Time	3.0V	3TpC		3TpC			1,3,7,8
			5.5V	3TpC		3TpC			1,3,7,8
9	TwIH	Int. Request Input High Time	3.0V	3TpC		3TpC			1,2,7,8
			5.5V	3TpC		2TpC			1,2,7,8
10	Twsm	STOP-Mode Recovery Width Spec	3.0V	12		12		ns	4,8
			5.5V	12		12		ns	4,8
11	Tost	Oscillator Startup Time	3.0V		5TpC		5TpC		4,8,9
			5.5V		5TpC		5TpC		4,8,9

### Notes:

1. Timing Reference uses 0.7 V<sub>cc</sub> for a logic 1 and 0.2 V<sub>cc</sub> for a logic 0.
2. Interrupt request via Port 3 (P33-P31).
3. Interrupt request via Port 3 (P30).
4. SMR-D5 = 1, POR STOP mode delay is on.
5. Reg. WDTMR.
6. The V<sub>cc</sub> voltage specification of 3.0V guarantees 3.3V ±0.3V, and the V<sub>cc</sub> voltage specification of 5.5V guarantees 5.0V ±0.5V.
7. SMR D1 = 0.
8. Maximum frequency for internal system clock is 4 MHz when using XTAL divide-by-one mode.
9. For XTAL and LC oscillator, and for oscillator driven by clock driver.

## AC ELECTRICAL CHARACTERISTICS

### Handshake Timing Diagrams

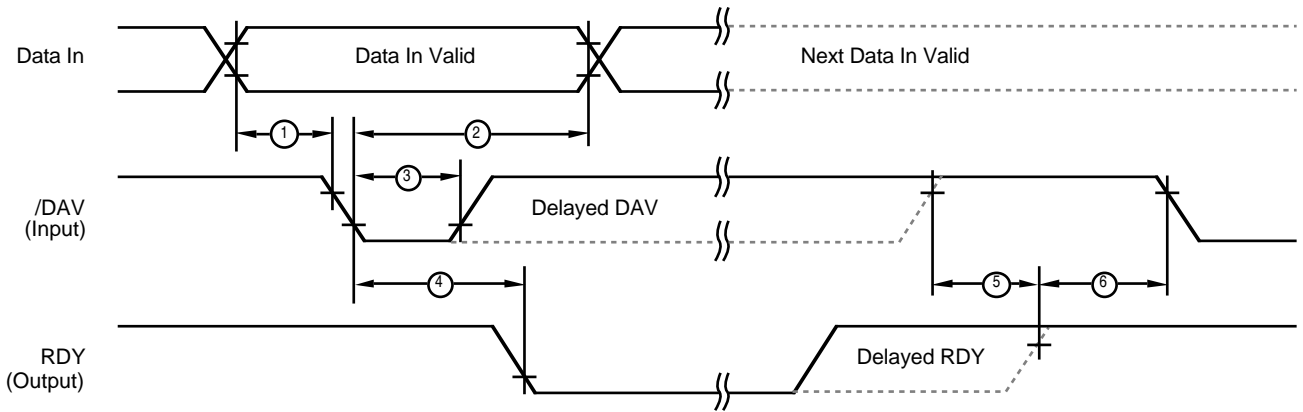

Figure 8. Input Handshake Timing

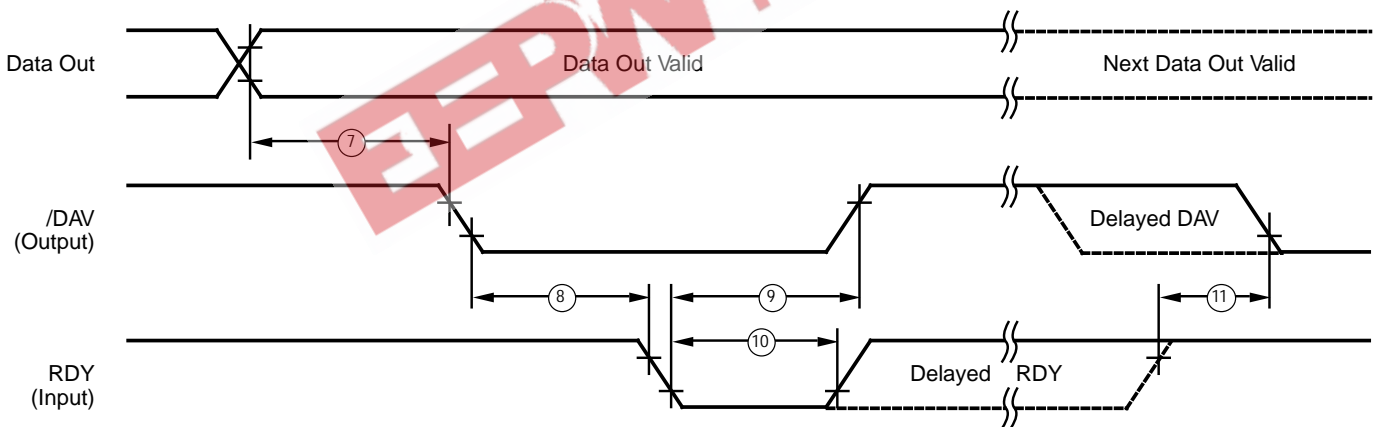

Figure 9. Output Handshake Timing

## AC ELECTRICAL CHARACTERISTICS (Continued)

Handshake Timing Table

No	Symbol	Parameter	V <sub>cc</sub> Note1,2	T <sub>A</sub> = 0°C to +70°C		T <sub>A</sub> = -40°C to +105°C		Data Direction
				12 MHz Min	16 MHz Max	12 MHz Min	16 MHz Max	
1	TsDI(DAV)	Data In Setup Time	3.0V	0	0	0	0	IN
			5.5V	0	0	0	0	IN
2	ThDI(DAV)	Data In Hold Time	3.0V	160	160	160	160	IN
			5.5V	115	115	115	115	IN
3	TwDAV	Data Available Width	3.0V	155	155	155	155	IN
			5.5V	110	110	110	110	IN
4	TdDAVI(RDY)	DAV Fall to RDY Fall Delay	3.0V	160	160	160	160	IN
			5.5V	115	115	115	115	IN
5	TdDAVI(d)(RDY)	DAV Rise to RDY Rise Delay	3.0V	120	120	120	120	IN
			5.5V	80	80	80	80	IN
6	TdRDY0(DAV)	RDY Rise to DAV Fall Delay	3.0V	0	0	0	0	IN
			5.5V	0	0	0	0	IN
7	TdD0(DAV)	Data Out to DAV Fall Delay	3.0V	42	31	42	31	OUT
			5.5V	42	31	42	31	OUT
8	TdDAV0(RDY)	DAV Fall to RDY Fall Delay	3.0V	0	0	0	0	OUT
			5.5V	0	0	0	0	OUT
9	TdRDY0(DAV)	RDY Fall to DAV Rise Delay	3.0V	160	160	160	160	OUT
			5.5V	115	115	115	115	OUT
10	TwRDY	RDY Width	3.0V	110	110	110	110	OUT
			5.5V	80	80	80	80	OUT
11	TdRDY0d(DAV)	RDY Rise to DAV Fall Delay	3.0V	110	110	110	110	OUT
			5.5V	80	80	80	80	OUT

**Notes:**

1. Timing Reference uses 0.7 V<sub>cc</sub> for a logic 1 and 0.2 V<sub>cc</sub> for a logic 0.
2. The V<sub>cc</sub> voltage specification of 3.0V guarantees 3.3V ±0.3V and the V<sub>cc</sub> voltage specification of 5.5V guarantees 5.0V ±0.5V.

**Table 5. D/A Converter Electrical Characteristics**  
 $V_{CC} = 3.3V \pm 10\%$

Parameter	Minimum	Typical	Maximum	Units
Resolution		8		Bits
Integral non-linearity		0.25	1	LSB
Differential non-linearity		0.25	0.5	LSB
Setting time, 1/2 LSB		1.5	3.0	μsec
Zero Error at 25°C		10	20	mV
Full Scale error at 25°C		0.25	0.5	LSB
Supply Range	3.0	3.3	3.6	Volts
Power dissipation, no load		10		mW
Ref Input resistance	2K	4K	10K	Ohms
Output noise voltage		50		μVp-p
VDHI range at 3 volts	1.5	1.8	2.1	Volts
VDLO range at 3 volts	0.2	0.5	0.8	Volts
VDHI–VDLO, at 3 volts	1.3	1.6	1.9	Volts
Capacitive output load, CL			20	pF
Resistive output load, RL	50K			Ohms
Output slew rate	1.0	3.0		V/μsec

**Notes:**

Voltage: 3.0V to 3.6V

Temp: 0–70°C

**Table 6. D/A Converter Electrical Characteristics**  
 $V_{CC} = 5.0V \pm 10\%$

Parameter	Minimum	Typical	Maximum	Units
Resolution		8		Bits
Integral non-linearity		0.25	1	LSB
Differential non-linearity		0.25	0.5	LSB
Setting time, 1/2 LSB		1.5	3.0†	μsec
Zero Error at 25°C		10	20	mV
Full Scale error at 25°C		1	2	% FSR
Supply Range	4.5	5.0	5.5	Volts
Power dissipation, no load		50	85	mW
Ref Input resistance	2K	4K	10K	Ohms
Output noise voltage		50		μVp-p
VDHI range at 5 volts	2.6		3.5	Volts
VDLO range at 5V volts	0.8		1.7	Volts
VDHI–VDLO, at 5V volts	0.9		2.7	Volts
Capacitive output load, CL			30	pF
Resistive output load, RL	20K			Ohms
Output slew rate	1.0	3.0		V/μsec

**Notes:**

Voltage: 4.5V - 5.5V

Temp: 0-70°C

† The C84 Emulator has maximum setting time of 20 μsec. (10 μsec. typical).

## AC ELECTRICAL CHARACTERISTICS (Continued)

**Table 7. A/D Converter Electrical Characteristics**  
 $V_{CC} = 3.3V \pm 10\%$

Parameter	Minimum	Typical	Maximum	Units
Resolution		8		Bits
Integral non-linearity		0.5	1	LSB
Differential non-linearity		0.5	1	LSB
Zero Error at 25°C			5.0	mV
Supply Range	3.0	3.3	3.6	Volts
Power dissipation, no load		20	40	mW
Clock frequency			24	MHz
Input voltage range	$V_{A_{LO}}$		$V_{A_{HI}}$	Volts
Conversion time	4.3		35 X SCLK	μsec
Input capacitance on ANA	25		40	pF
$V_{A_{HI}}$ range	$V_{A_{LO}} + 2.5$		$V_{CC}$	Volts
$V_{A_{LO}}$ range	$AN_{GND}$		$V_{CC} - 2.5$	Volts
$V_{A_{HI}} - V_{A_{LO}}$	2.5		$V_{CC}$	Volts

**Notes:**

Voltage: 3.0V to 3.6V

Temp: 0-70°C

SCLK = System Clock on Bus Speed.

**Table 8. A/D Converter Electrical Characteristics**  
 $V_{CC} = 5.0V \pm 10\%$

Parameter	Minimum	Typical	Maximum	Units
Resolution		8		Bits
Integral non-linearity		0.5	1	LSB
Differential non-linearity		0.5	1	LSB
Zero Error at 25°C			45	mV
Supply Range	4.5	5.0	5.5	Volts
Power dissipation, no load		50	85	mW
Clock frequency			33	MHz
Input voltage range	$V_{A_{LO}}$		$V_{A_{HI}}$	Volts
Conversion time	4.3		35 X SCLK	μsec
Input capacitance on ANA	25		40	pF
$V_{A_{HI}}$ range	$V_{A_{LO}} + 2.5$		$V_{CC}$	Volts
$V_{A_{LO}}$ range	$AN_{GND}$		$V_{CC} - 2.5$	Volts
$V_{A_{HI}} - V_{A_{LO}}$	2.5		$V_{CC}$	Volts

**Notes:**

Voltage: 4.5V –5.5V

Temp: 0-70°C

Conversion time is defined as the time from initiation of A-D conversion to storage of the digital result in the ADR register.

SCLK = System Clock on Bus Speed.

## PIN FUNCTIONS

### Application Precaution

The production test-mode environment may be enabled accidentally during normal operation if **excessive noise surges above  $V_{cc}$**  occur on the /RESET pin.

Recommendations for dampening voltage surges in both test and OTP mode include the following:

- Using a clamping diode to /RESET
- Adding a capacitor to the affected pin

**XTAL1.** *Crystal 1* (time-based input). This pin connects a parallel-resonant crystal, ceramic resonator, LC network or an external single-phase clock to the on-chip oscillator input.

**XTAL2.** *Crystal 2* (time-based output). This pin connects a parallel-resonant crystal, ceramic resonator, LC network to the on-chip oscillator output.

**Port 0 P00-P06.** (*P03-P06 is not available on the Z86C84*). Port 0 is a 7-bit, bidirectional, CMOS-compatible I/O port. These seven I/O lines can be nibble programmable as P00-P03 input/output and P04-P06 input/output, separately (Figure 10). All input buffers are Schmitt-triggered and output drivers are push-pull. There is a ROM mask option to enable 100K ( $\pm 40\%$ ) pull-up resistors to Port 0, P00 to P02.

**Port 0 Auto Latch.** (*Auto Latch Mask Option available only on P00-P02. P03-P06 has the Auto Latches permanently enabled.*) The Auto Latch provides valid CMOS Levels when P00-P06 (P00-P02 on C84) are selected as inputs and not externally driven. It is impossible to determine if a non-driven input is 1 or 0, however; the Auto Latch will sense the input condition and drive a valid CMOS level, thereby eliminating a floating mode that could cause excessive current. (Auto Latch is a ROM mask option for the Z86C83, Z86C84).

**Port 2 (P27-P20)** Port 2 is an 8-bit, bi-directional, CMOS-compatible I/O port and an 8-channel muxed input to the 8-bit ADC. When configured as a digital input, by programming the Port2 Mode register, the Port 2 register can be evaluated to read digital data applied to Port 2, or the ADC result register can be read to evaluate the analog signals applied to Port 2 after configuring the ADC Control Registers. The direction of each of the eight Port 2 I/O lines can be configured individually (Figure 11).

In addition, all four versions of the device provide the capability of connecting 10K ( $\pm 20\%$ ) pull-up resistors to each of the Port 2 I/O lines individually. The pull-ups are connected when activated through software control of P2RES register (Figure 67) when the corresponding Port 2 pin is configured to be an input. The pull-up resistor of a Port 2 I/O line is automatically disabled when the corresponding I/O is an output, regardless of the state of the corresponding P2RES bit value.

**Note:** The Z86C83/C84 Emulator does not emulate the P2RES Register. Selection of the pull-ups are done via jumper settings on the emulator.



PIN FUNCTIONS (Continued)

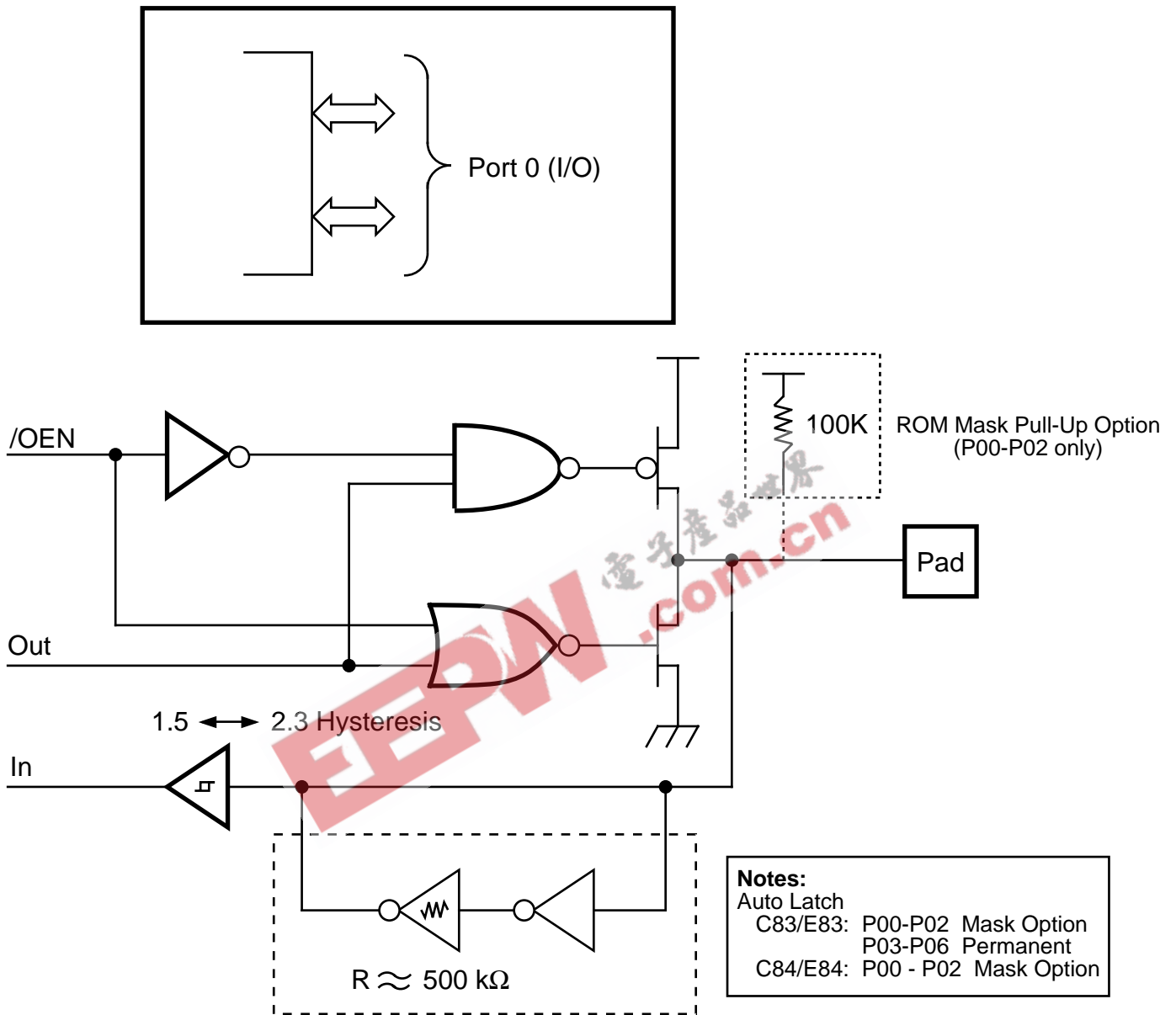

Figure 10. Port 0 Configuration

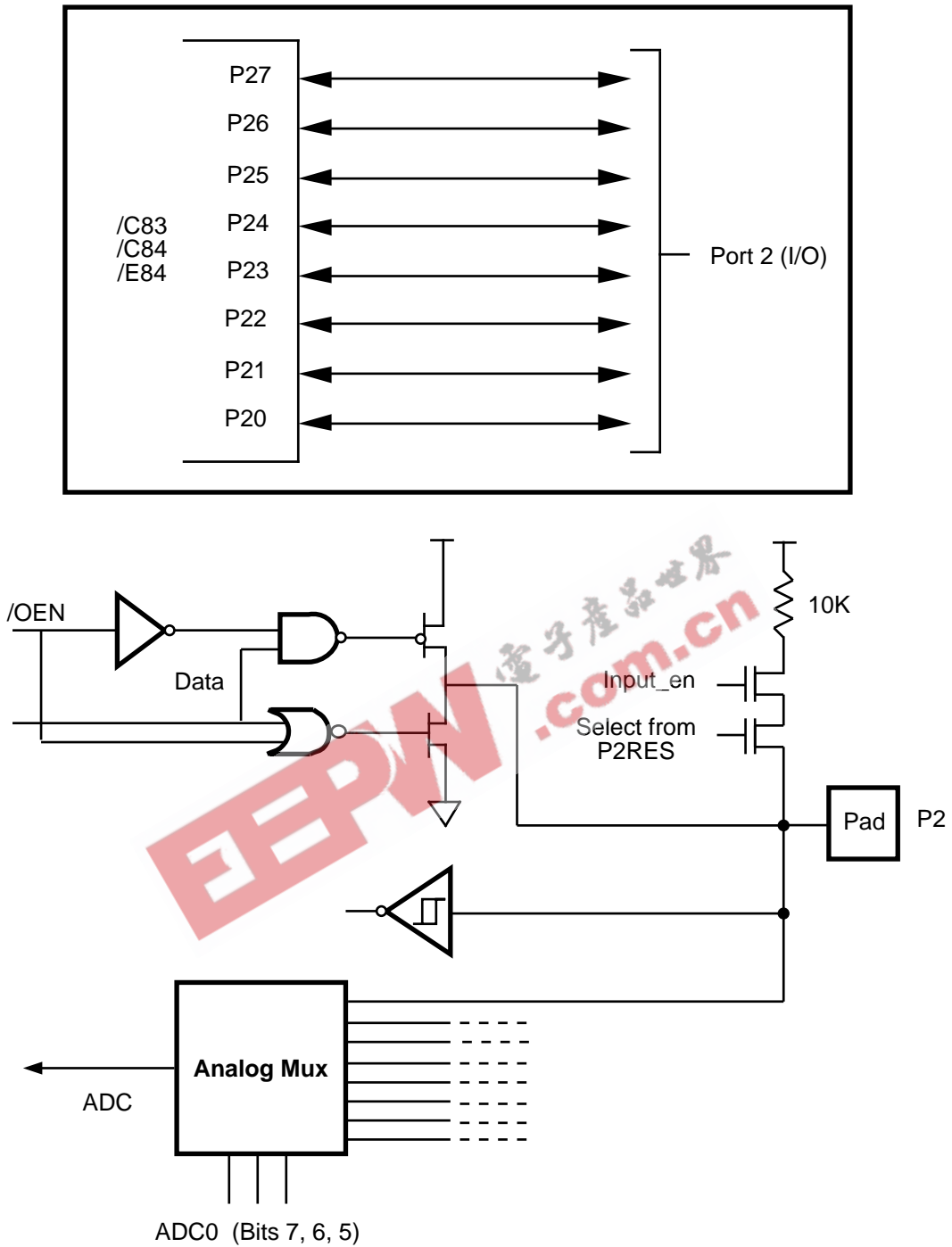

Figure 11. Port 2 Configuration

## PIN FUNCTIONS (Continued)

**Port 3 (P37-P30).** Port 3 is a 6-bit, CMOS-compatible port, with three fixed inputs (P33-P31) and three fixed outputs (P34-P36), configured under software control for Input/Output, Counter/Timers, interrupt, and port handshake. P31, P32, and P33 are standard CMOS inputs (no Auto Latches). Pins P34, P35, and P36 are push-pull output lines (Figure 11). Low EMI output buffers can be globally programmed by the software.

Two on-board comparators can process analog signals on P31 and P32 with reference to the voltage on P33. The analog function is enabled by programming Port 3 Mode Register (P3M bit 1). For Interrupt functions, Port 3, pin 3 is falling-edge interrupt input. P31 and P32 are programmable as rising, falling, or both edge triggered interrupts (IRQ register bits 6 and bit 7). P33 is the comparator reference voltage input when in Analog Mode. Access to Counter/Timers 1 is made through P31 ( $T_{IN}$ ) and P36 ( $T_{OUT}$ ). Handshake lines for Ports 0 and 2 are available on P31/P36 and P32/P35 (Table 9).

Port 3 also provides the following control functions: handshake for Ports 0 and 2 (/DAV and RDY); three external interrupt request signals (IRQ2-IRQ0); timer input and output signals ( $T_{IN}$  and  $T_{OUT}$ ).

**Table 9. Port 3 Pin Assignments**

Pin	I/O	CTC1	Analog	Int.	P0 HS	P2 HS
P31	IN	$T_{IN}$	AN1	IRQ2		D/R
P32	IN		AN2	IRQ0	D/R	
P33	IN		REF	IRQ1		
P34	OUT		AN1-OUT			
P35	OUT				R/D	
P36	OUT	$T_{OUT}$				R/D

**Notes:**

HS = Handshake Signals  
D = /DAV  
R = RDY

**Auto Latch.** The Auto-Latch instruction puts valid CMOS levels on all CMOS inputs (except P33-P31) that are not externally driven. Whether this level is 0 or 1, cannot be determined. A valid CMOS level, rather than a floating node, reduces excessive supply current flow in the input buffer.

**Notes:**

1. Deletion of Port Auto Latches is available as a ROM mask option. The Auto Latch Delete option is selected by the customer when the ROM code is submitted.
2. Ports 03, 04, 05, 07 have permanently enabled Auto Latches.

**Comparator Inputs.** Port 3, P31 and P32, each have a comparator front end. The comparator reference voltage, P33, is common to both comparators. In analog mode, the P33 input functions as a reference voltage to the comparators. In Analog Mode, the internal P33 register and its corresponding IRQ1 is connected to the Stop-Mode Recovery source selected by the SMR register. In this mode, any of the Stop-Mode Recovery sources are used to toggle the P33 bit or generate IRQ1. In Digital Mode, P33 can be used as a Port 3 register input or IRQ1 source. P34 outputs the comparator outputs by software programming the PCON Register bit D0 to 1.

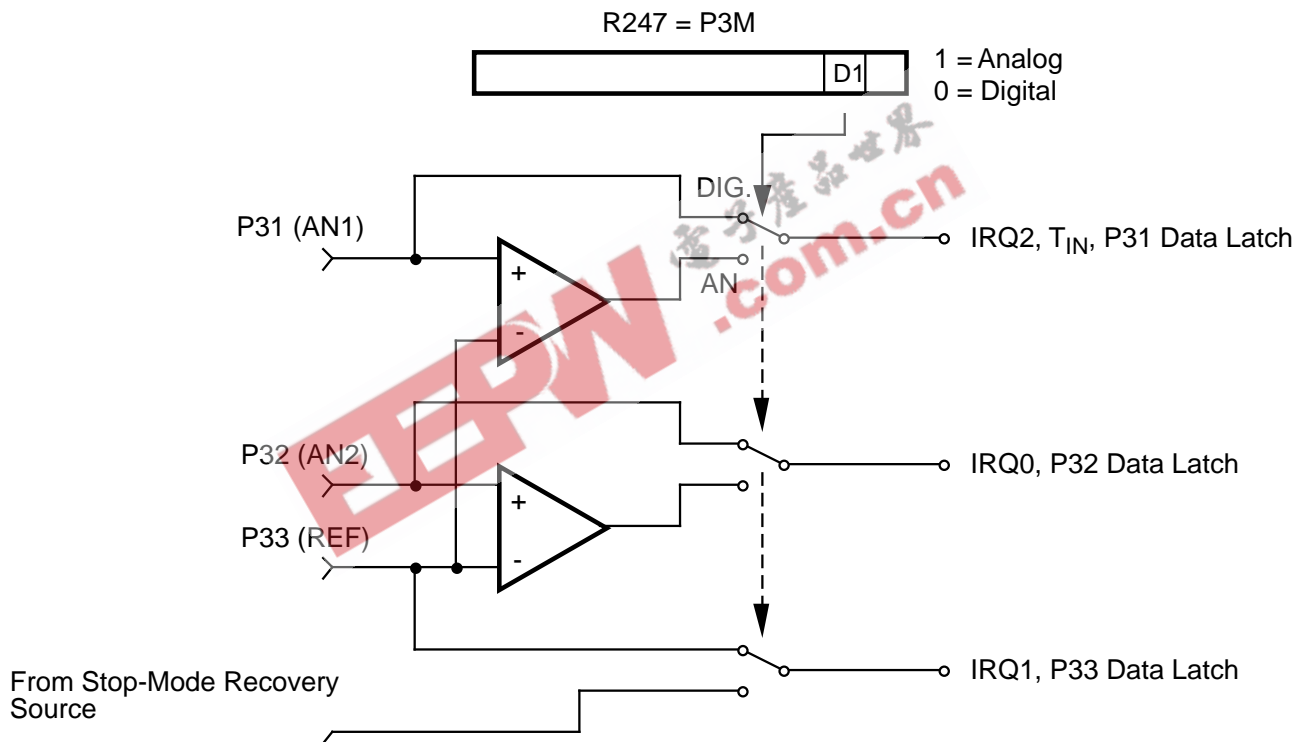
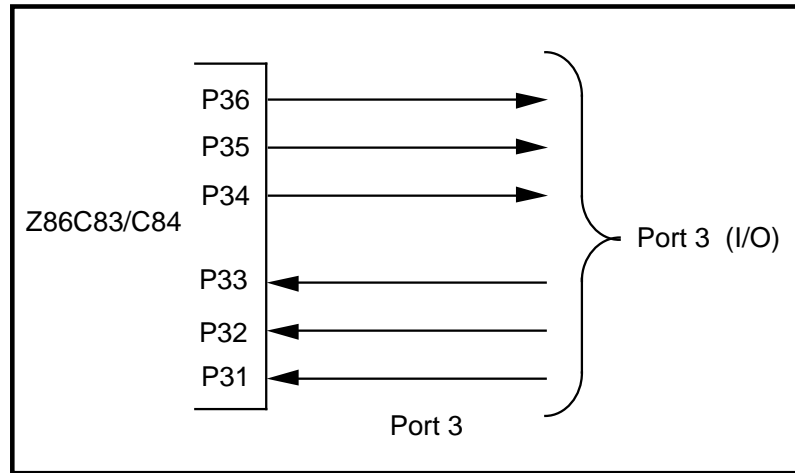

Figure 12. Port 3 Input Configuration

## PIN FUNCTIONS (Continued)

**Port Configuration Register (PCON).** The PCON configures the ports individually for comparator output on Port 3. The PCON Register is located in the Expanded Register File at Bank F, location 00 (Figure 13).

Bit 0 multiplexes comparator AN1 Output at P34. A "1" in this location brings the comparator output to P34

(Figure 14), and a "0" puts P34 into its standard I/O configuration.

**Note:** Only comparator output AN1 is multiplexed to a Port 3 output. Comparator AN2 output is not connected to any pins. Note that the PCON Register is reset upon the occurrence of a WDT RESET (not in Stop Mode), and Power-On Reset (POR).

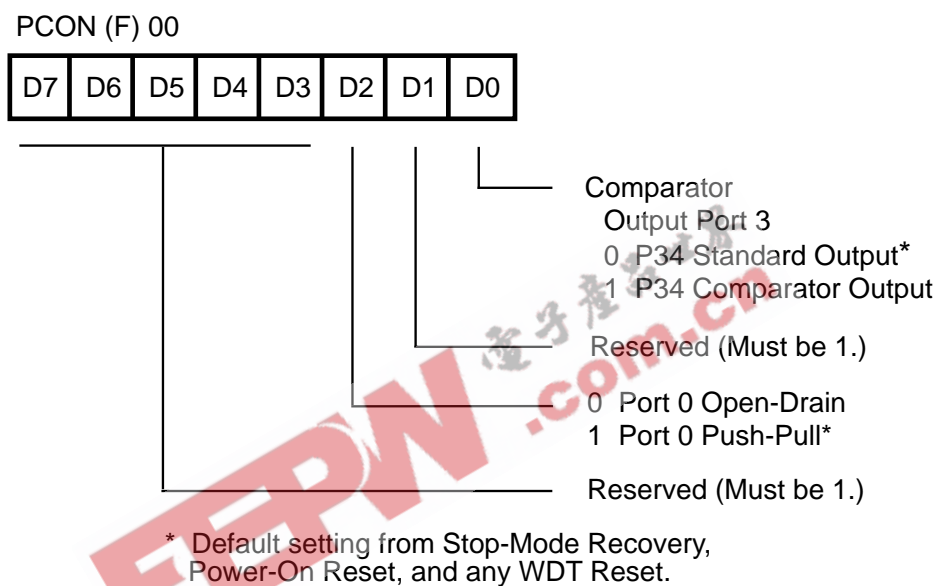

Figure 13. Port Configuration Register (PCON) (Write-Only)

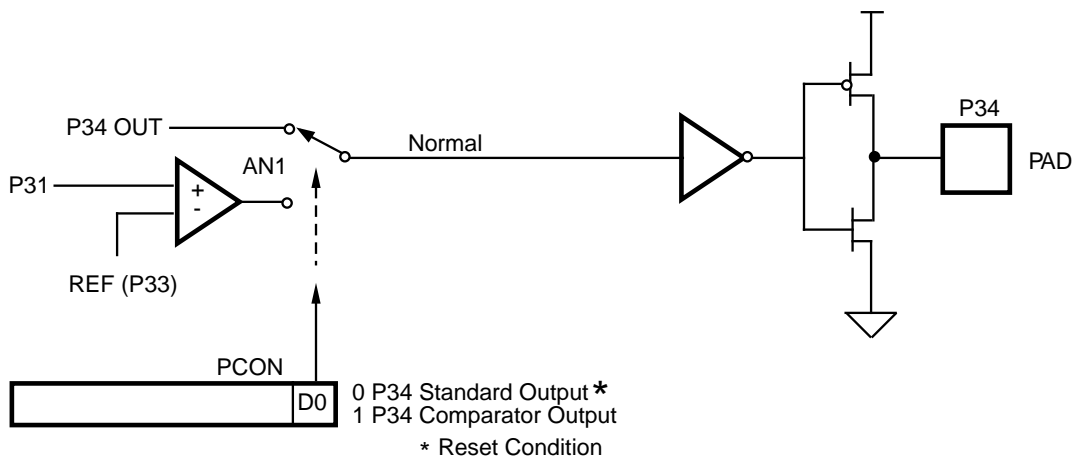

Figure 14. Port 3 P34 Output Configuration

## FUNCTIONAL DESCRIPTION

**RESET.** (*Input, Active Low*). This pin initializes the MCU. Reset is accomplished either through Power-On Reset (POR), Watch-Dog Timer (WDT) Reset, or external reset. During POR, and WDT Reset, the internally generated reset is driving the reset pin Low for the POR time. **Any devices driving the reset line must be open-drain to avoid damage from a possible conflict during reset conditions.** Pull-up is provided internally.

After the POR time, /RESET is a Schmitt-triggered input. After the reset is detected, an internal RST signal is latched and held for an internal register count of 18 external clocks, or for the duration of the external reset, whichever is longer. Program execution begins at location 000C (hex), 5-10 T<sub>PC</sub> cycles after the RST is released. For POR, the reset output time is T<sub>POR</sub>.

**Program Memory.** C83/C84 can address up to 4 KB of internal Program Memory (Figure 15). The first 12 bytes of program memory are reserved for the interrupt vectors. These locations contain six 16-bit vectors that correspond to the six available interrupts. Bytes 13 to 4095 consist of on-chip, mask-programmed ROM.

**ROM Protect.** The 4 KB of Program Memory is mask programmable. A ROM protect feature will prevent dumping of the ROM contents from an external program outside the ROM.

**Expanded Register File.** The register file has been expanded to allow for additional system control registers and for mapping of additional peripheral devices and input/output ports into the register address area. The Z8 register address space R0 through R15 is implemented as 16 groups of 16 registers per group (Figure 16). These register banks are known as the Expanded Register File (ERF). Bits 3-0 of the Register Pointer (RP) select the active ERF bank. Bits 7-4 of register RP select the working register group (Figure 17). Four system configuration registers reside in the ERF address space in Bank F and eight registers reside in Bank C. The rest of the ERF addressing space is not physically implemented, and is open for future expansion.

**Note:** When using Zilog's Cross Assembler version 2.1 or earlier, use the LD RP, #0X instruction rather than the SRP #0X instruction to access the ERF.

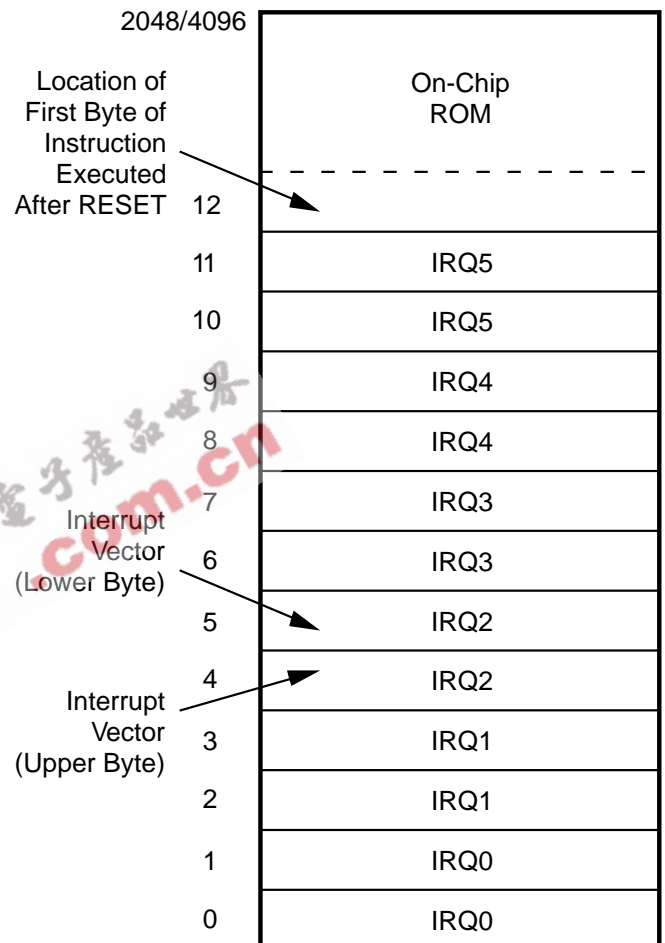

Figure 15. Program Memory Map

FUNCTIONAL DESCRIPTION (Continued)

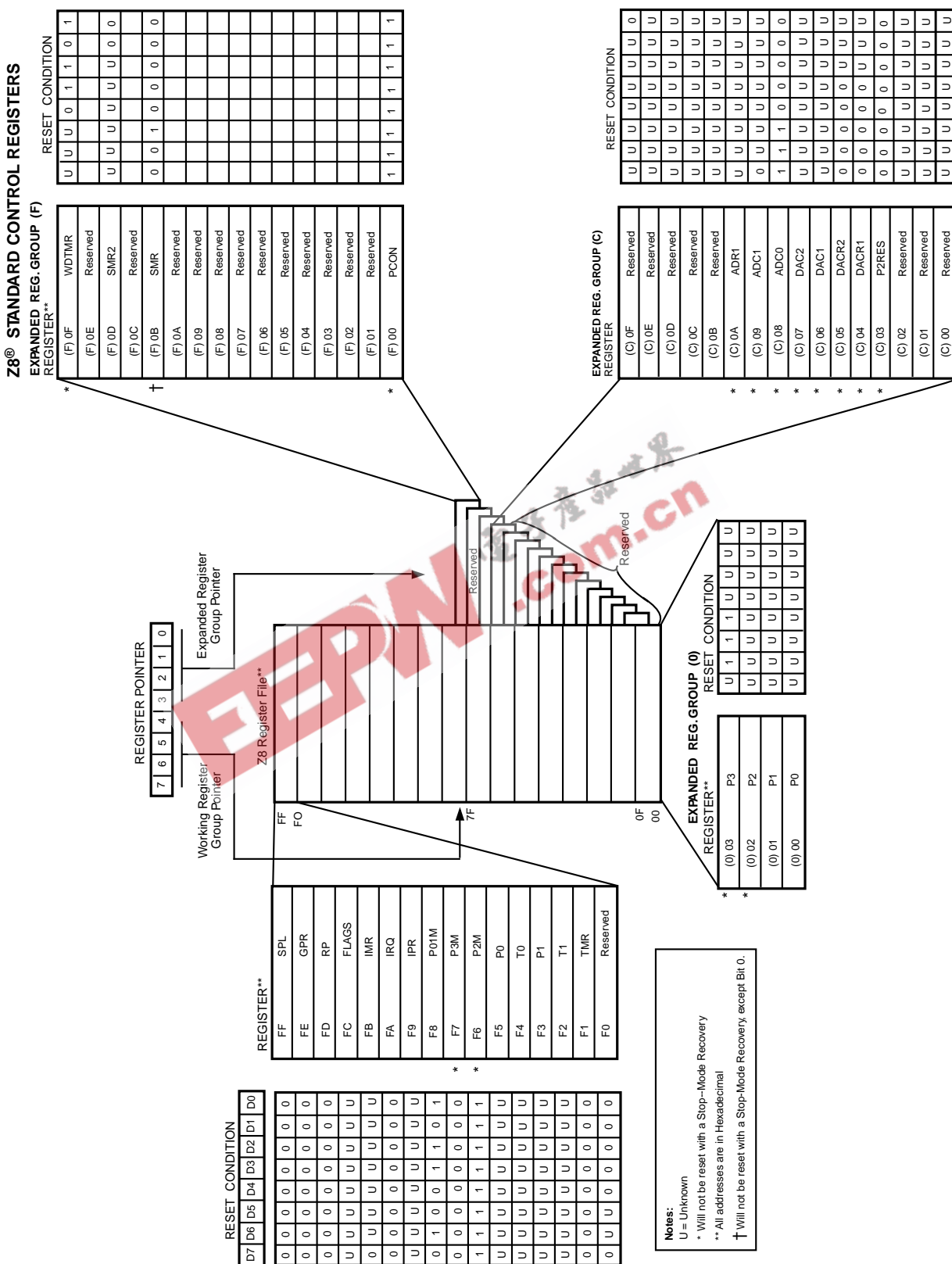

Figure 16. Expanded Register File Architecture

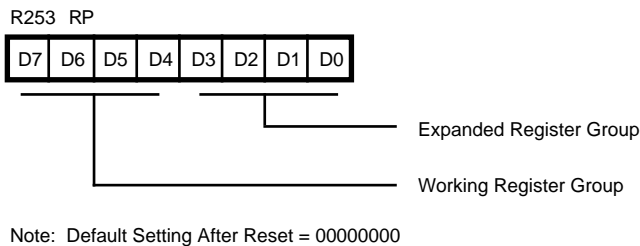

Figure 17. Register Pointer Register

**Register File.** The Register File consists of three I/O port registers, 237 general-purpose registers, 15 control and status registers, and four system configuration registers in the Expanded Register Group (Figure 16). The instructions can access registers directly or indirectly through an 8-bit address field. This allows a short 4-bit register address using the Register Pointer (Figure 18). In the 4-bit mode, the Register File is divided into 16 working register groups, each occupying 16 continuous locations. The Register Pointer addresses the starting location of the active working-register group.

**Note:** Register Bank E0-EF is only accessed through working registers and indirect addressing modes.

**CAUTION:** D4 of Control Register P01M (R251) must be 0.

**R254.** The C83/C84 has one extra general-purpose register located at FEH (R254). It is set to 00H after any reset.

**Stack.** The C83/C84 has an 8-bit Stack Pointer (R255) used for the internal stack that resides within the 236 general-purpose registers. Register R254 cannot be used for stack.

**General-Purpose Registers (GPR).** These registers are undefined after the device is powered up. The registers keep their last value after any reset, as long as the reset occurs in the  $V_{cc}$  voltage-specified operating range. It will not keep its last state from a  $V_{LV}$  reset if the  $V_{cc}$  drops below 1.8V. This includes Register R254.

**Note:** Register Bank E0-EF is only accessed through working register and indirect addressing modes.

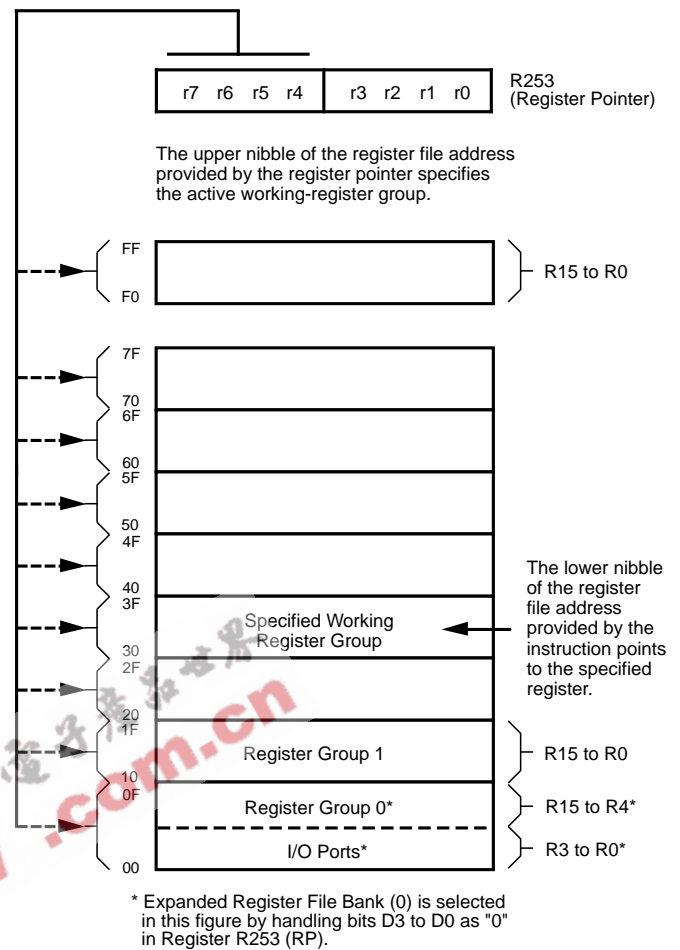

Figure 18. Register Pointer

**RAM Protect.** The upper portion of the RAM's address spaces %80F to %EF (excluding the control registers) are protected from reading and writing. The RAM Protect bit option is mask-programmable and is selected by the customer when the ROM code is submitted. After the mask option is selected, the user activates this feature from the internal ROM code to turn off/on the RAM Protect by loading either a 0 or 1 into the Interrupt Mask (IMR) register, bit D6. A 1 in D6 enables RAM Protect.



## FUNCTIONAL DESCRIPTION (Continued)

**Counter/Timers.** There are two 8-bit programmable counter/timers (T0-T1), each driven by its own 6-bit programmable prescaler. The T1 prescaler is driven by internal or external clock sources; however, the T0 prescaler is driven by the internal clock only (Figure 19).

The 6-bit prescalers can divide the input frequency of the clock source by any integer number from 1 to 64. Each prescaler drives its counter, which decrements the value (1 to 256) that has been loaded into the counter. When the counter reaches the end of the count, a timer interrupt request, IRQ4 (T0) or IRQ5 (T1), is generated.

The counters can be programmed to start, stop, restart to continue, or restart from the initial value. The counters can

also be programmed to stop upon reaching zero (single pass mode) or to automatically reload the initial value and continue counting (modulo-n continuous mode).

The counters, **but not the prescalers**, are read at any time without disturbing their value or count mode. The clock source for T1 is user-definable and is either the internal microprocessor clock divide-by-four, or an external signal input through Port 3. The Timer Mode register configures the external timer input (P31) as an external clock, a trigger input that can be retriggerable or non-retriggerable, or as a gate input for the internal clock. The counter/timers can be cascaded by connecting the T0 output to the input of T1. T<sub>IN</sub> Mode is enabled by setting R243 PRE1 Bit D1 to 0.

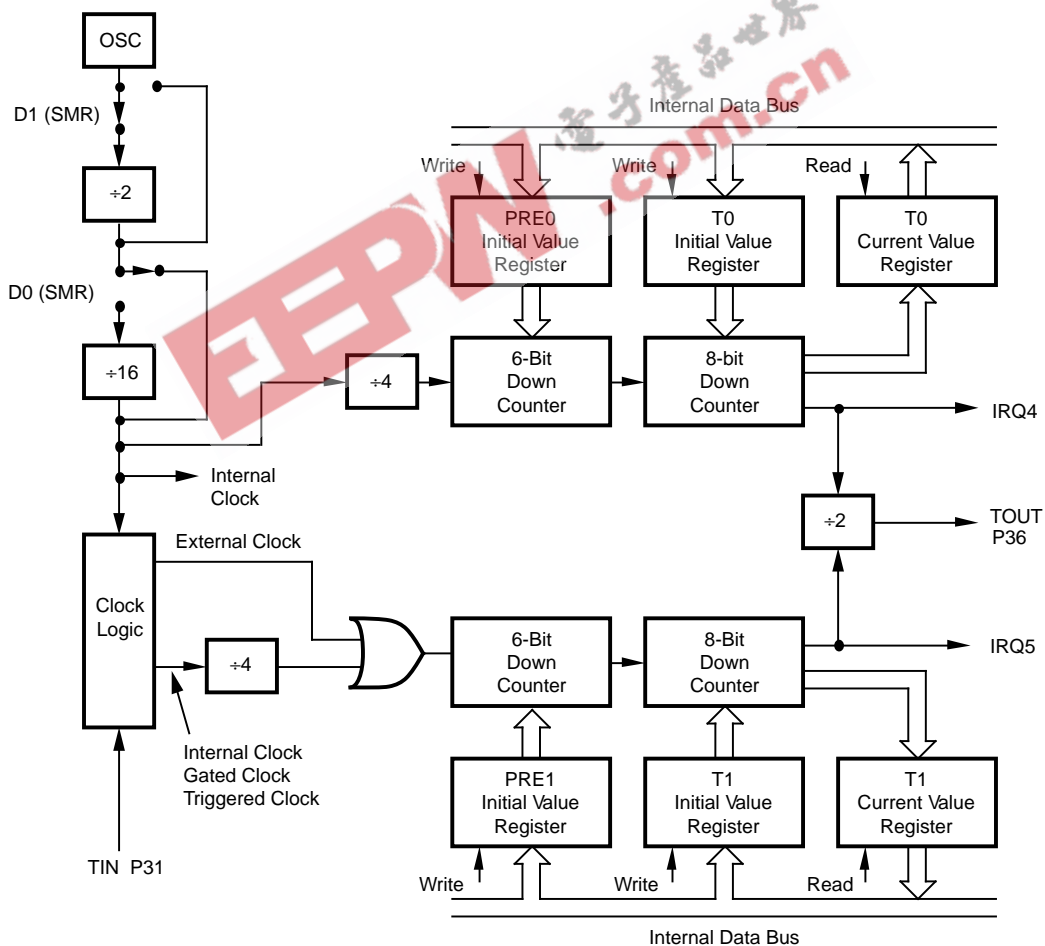

Figure 19. Counter/Timer Block Diagram

**Interrupts.** The Z8 has six different interrupts from six different sources. These interrupts are maskable, prioritized (Figure 20) and the six sources are divided as follows: four sources are claimed by Port 3 lines P33-P30, and two in counter/timers (Table 10). The Interrupt Mask Register globally or individually enables or disables the six interrupt requests.

When more than one interrupt is pending, priorities are resolved by a programmable priority encoder that is controlled by the Interrupt Priority register. An interrupt machine cycle is activated when an interrupt request is granted. This action disables all subsequent interrupts, saves the Program Counter and Status Flags, and then branches to the program memory vector location reserved for that interrupt.

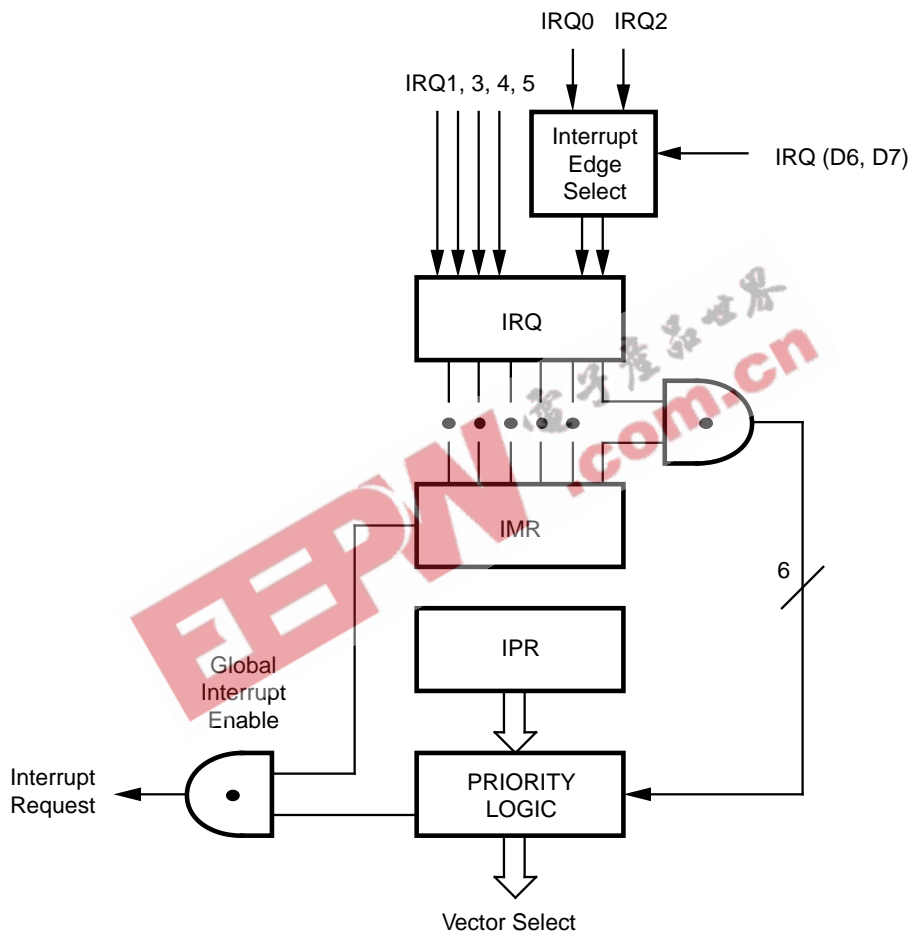

Figure 20. Interrupt Block Diagram

Table 10. Interrupt Types, Sources, and Vectors

Name	Source	Vector Location	Comments
IRQ0	/DAV0, IRQ0	0, 1	External (P32), Rise/ Fall Edge Triggered
IRQ1,	IRQ1	2, 3	External (P33), Fall Edge Triggered
IRQ2	/DAV2, IRQ2, T <sub>IN</sub>	4, 5	External (P31), Rise /Fall Edge Triggered
IRQ3	IRQ3	6, 7	By User Software
IRQ4	T0	8, 9	Internal
IRQ5	T1	10, 11	Internal

## FUNCTIONAL DESCRIPTION (Continued)

All Z8 interrupts are vectored through locations in the program memory. This memory location and the next byte contain the 16-bit address of the interrupt service routine for that particular interrupt request. To accommodate polled interrupt systems, interrupt inputs are masked and the Interrupt Request register is polled to determine which of the interrupt requests need service.

An interrupt resulting from AN1 is mapped into IRQ2, and an interrupt from AN2 is mapped into IRQ0. Interrupts IRQ2 and IRQ0 may be rising, falling, or both edge triggered, and are programmable by the user. The software may poll to identify the state of the pin.

Programming bits for the Interrupt Edge Select is located in the IRQ Register (R250), bits D7 and D6. The configuration is shown in Table 11.

**Table 11. IRQ Register**

IRQ		Interrupt Edge	
D7	D6	P31	P32
0	0	F	F
0	1	F	R
1	0	R	F
1	1	R/F	R/F

**Notes:**  
F = Falling Edge  
R = Rising Edge

**Clock.** The Z8 on-chip oscillator has a high-gain, parallel-resonant amplifier for connection to a crystal, LC, RC, ceramic resonator, or any suitable external clock source (XTAL1 = Input, XTAL2 = Output). The crystal should be AT cut, 16 MHz max., with a series resistance (RS) of less than or equal to 100 Ohms when clocking from 1 MHz to 16 MHz.

The crystal should be connected across XTAL1 and XTAL2 using the vendor's recommended capacitor values from each pin directly to the device Ground pin to reduce Ground noise injection into the oscillator.

**Note:** For better noise immunity, the capacitors should be tied directly to the device Ground pin ( $V_{SS}$ ).

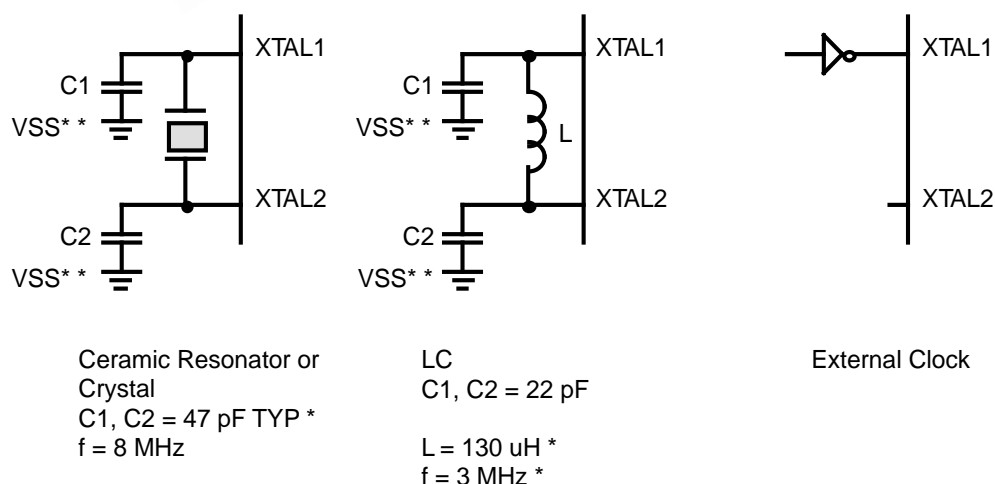

\* Preliminary value including pin parasitics  
\*\* Device ground pin

**Figure 21. Oscillator Configuration**

## Analog-to-Digital Converter

The Analog-to-Digital (ADC) is an 8-bit half flash converter that uses two reference resistor ladders for its upper 4 bits (MSBs) and lower 4 bits (LSBs) conversion. Two reference voltage pins,  $AV_{CC}$  and  $A_{GND}$ , are provided for external reference voltage supplies. During the sampling period from one of the eight channel inputs, the converter is also being auto-zeroed before starting the conversion. The conversion time is dependent on the internal clock frequency. The minimum conversion time is  $35 \times SCLK$  (see Figure 22).

The ADC is controlled by the Z8® and its three registers (two Control and one Result) are mapped into the Extended Register File. A conversion can be initiated by writing to the ADC Control Register 0 after the ADC Control Register 1 is configured.

The start command is implemented in such a way as to begin a conversion at any time, if a conversion is in progress and a new start command is received, then the conversion in progress will be aborted and a new conversion will be initiated. This allows the programmed values to be changed without affecting a conversion-in-

progress. The new values will take effect only after a new start command is received.

The ADC can be disabled (for low power) or enabled by a Control Register bit.

Though the ADC will function for a smaller input voltage and voltage reference, the noise and offsets remain constant over the specified electrical range. The errors of the converter will increase and the conversion time may also take slightly longer due to smaller input signals.

### ADC Calibration Offset

Specially matched resistors are program-enabled to allow 35.0 percent or 50 percent offset from  $A_{GND}$ . They may selectively enable these resistors to offset the  $A_{GND}$  by 35.0 percent (2.5V to 5V) or 50 percent (1.75V to 5V) thereby allowing the 8-bit ADC across a narrower voltage range. This will allow significant resolution improvement within the reduced voltage range.

**Note:** The  $AV_{CC}$  must be the same value as  $V_{CC}$  and  $A_{GND}$  must be the same value as GND.

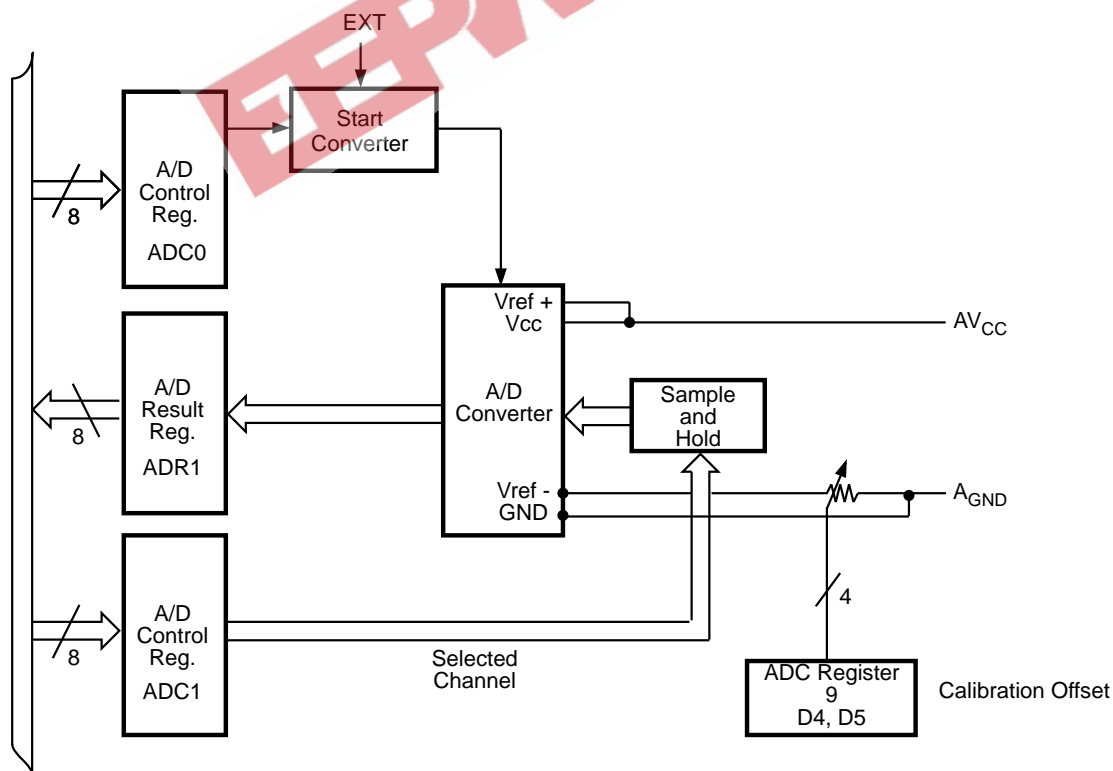

Figure 22. ADC Architecture

FUNCTIONAL DESCRIPTION (Continued)

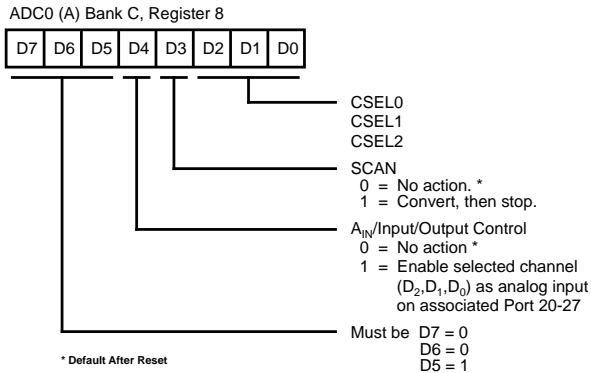

Figure 23. ADC Control Register 0 (Read/Write)

SCAN	
0	No action*
1	Convert channel then stop

Channel Select (bits 2, 1, 0).			
CSEL2	CSEL1	CSEL0	Channel
0	0	0	0 (P20)*
0	0	1	1 (P21)
0	1	0	2 (P22)
0	1	1	3 (P23)
1	0	0	4 (P24)
1	0	1	5 (P25)
1	1	0	6 (P26)
1	1	1	7 (P27)

**Note:** \*The desired P2 bit must be set equal 1 to allow Port bit ias ADC input.

Figure 24. ADC Control Register 1 (Read/Write)

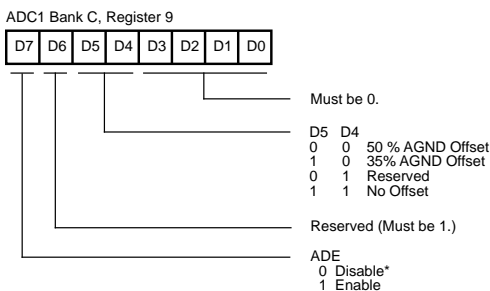

**ADE (bit 7).** A zero disables any A/D conversions or accessing any ADC registers except writing to ADE bit. A one Enables all ADC accesses. ADC result register is shown in Figure 25.

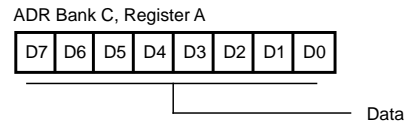

Figure 25. Result Register (Read-Only)

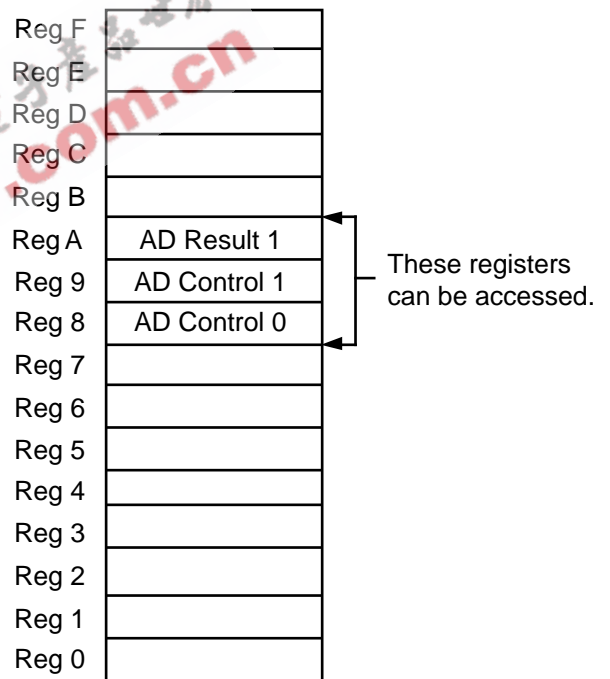

Figure 26. Bank C

Figure 27 shows the input circuit of the ADC. When conversion starts the analog input voltage is connected to the MSB and LSB flash converter inputs as shown in the Input Impedance CKT diagram. Effectively, shunting 31 parallel internal resistance of the analog switches and simultaneously charging 31 parallel 0.5 pF capacitors, which is equivalent to seeing a 400 Ohms input impedance

in parallel with a 16 pF capacitor. Other input stray capacitance adds about 10 pF to the input load. For input source resistances up to 2 kOhms can be used under normal operating condition without any degradation of the input settling time. For larger input source resistance, longer conversion cycle time may be required to compensate the input settling time problem.

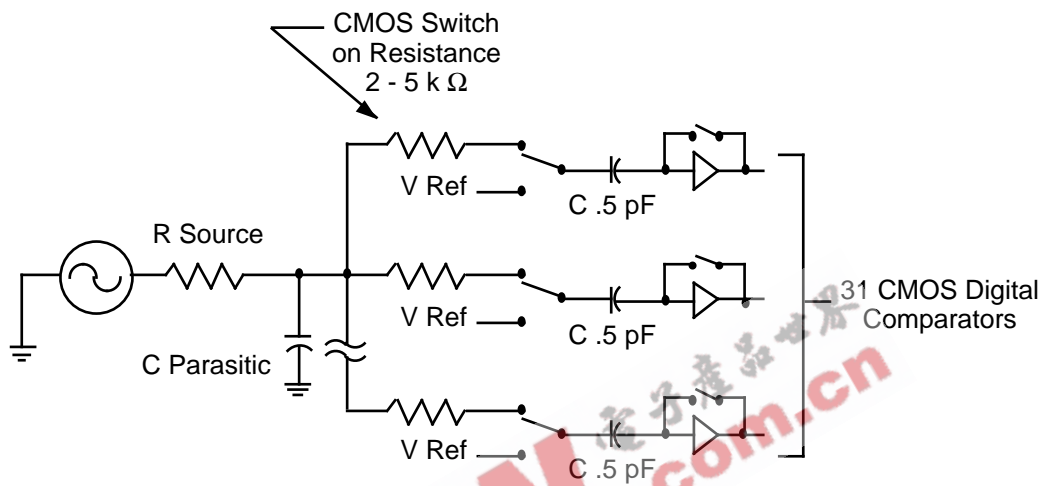

Figure 27. Input Impedance of ADC

### Typical Z8 A/D Conversion Sequence

1. Set the register pointer to Extended Bank (C), that is, SRP #0C instruction.
2. Next, set ADE flag by loading ADC1 Control Register Bank (C) Register 9, bit 7. Also, load bits 0-4 of this same register to select a  $AV_{CC}$  or  $A_{GND}$  offset value. A precision voltage divider connected to the A/D resistive ladder can offset conversion dynamic range to specified limits within the  $AV_{CC}$  and  $A_{GND}$  limits. By loading Bank (C) Register 9, bits 0-4, with the appropriate value it is possible to select from these groups:
  - a. No Offset. The Converter Dynamic range is from 0V to 5.0V for  $AV_{CC} = 5.0V$ .
  - b. 35 Percent  $A_{GND}$  Offset. The Converter Dynamic range is 1.75V - 5.0V for  $AV_{CC} = 5.0V$ .
  - c. 50 Percent  $A_{GND}$  Offset. The Converter Dynamic range is 2.5V - 5.0V for  $AV_{CC} = 5.0V$ .
3. Select one of the eight A/D inputs for conversion by loading Bank (C) Register 8 with the desired attributes: Bits 0 - 2 select an A/D input, bits 3 and 4 select A/D conversion (or digital port I/O).
4. Set Bank (C) Register 8, bit 3 to enable A/D conversion. (This flag can be set concurrently with step 3.) This flag is automatically reset when the A/D conversion is completed, so a bit test can be performed to determine A/D readiness if necessary.
5. Read the A/D result in Bank (C) Register A. Please note that the A/D result is not valid (indeterminate) unless ADE flag (Register 9, bit 7) was previously set, otherwise A/D converter output is tri-stated.

## FUNCTIONAL DESCRIPTION (Continued)

### Digital-to-Analog Converters

The Z86C84 has two Digital-to-Analog Converters (DACs). Each DAC is an 8-bit resistor string, with a programmable 0.25X, 0.5X, or 1X gain output buffer. The DAC output voltage settles after the internal data is latched into the DAC Data register. The top and bottom ends of the resistor ladder are register-selected to be connected to either the analog supply rails,  $AV_{CC}$  and  $A_{GND}$ , or two externally-provided reference voltages, VDHI and VDLO. External references are recommended to explicitly set the DAC output limits. Since the gain stage cannot drive to the

supply rails, VDHI and VDLO must be within ranges shown in the specifications. If either reference approaches the analog supply rails, the output will be unable to span the reference voltage range. The externally provided reference voltages should not exceed the supply voltages. The DAC outputs are latch-up protected and can drive output loads (Figure 28).

**Note:** The  $AV_{CC}$  must be the same value as  $V_{CC}$  and  $A_{GND}$  must be the same value as GND

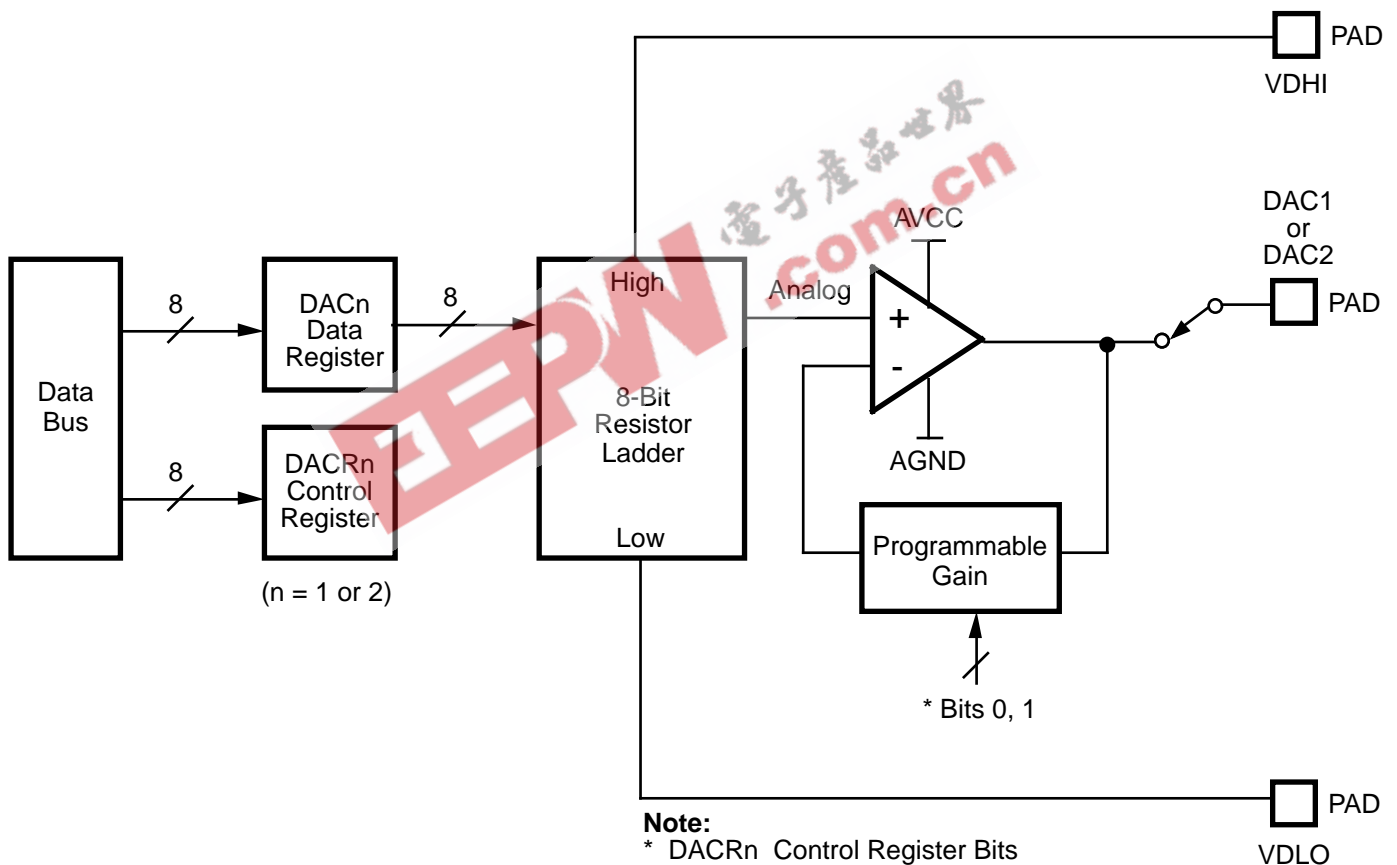

Figure 28. DAC Block Diagram

The D/A conversion for DAC1 is driven by writing 8-bit data to the DAC1 data register (Bank C, Register 06H). The D/A conversion for DAC 2 is controlled by the DAC2 data register (Bank C, Register 07H). Each DAC data register is initialized to midrange 80H on power-up.

There are two DAC control registers: DACR1 (Bank C, Register 04H) for DAC1, and DACR2 (Bank C, Register 05H) for DAC2. Control register bits 0 and 1 set the DAC gain. When DAC data is 80H, the DAC output is constant for any gain setting (Figure 29 and Figure 31).

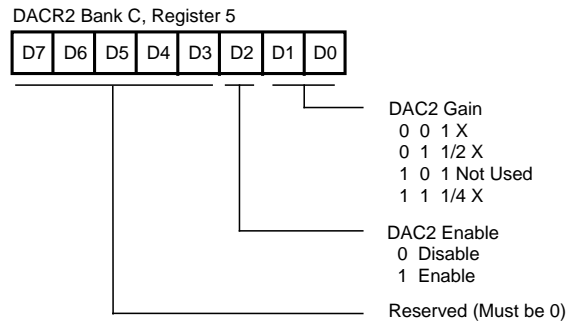

Figure 31. D/A 2 Control Register

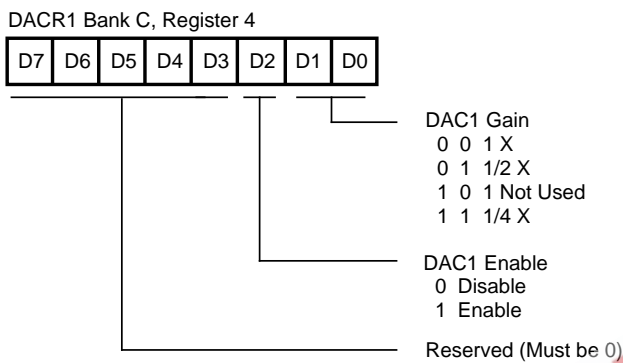

Figure 29. D/A 1 Control Register

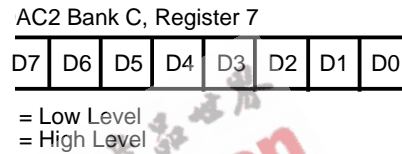

Figure 32. D/A 2 Data Register

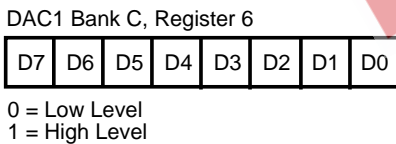

Figure 30. D/A 1 Data Register



FUNCTIONAL DESCRIPTION (Continued)

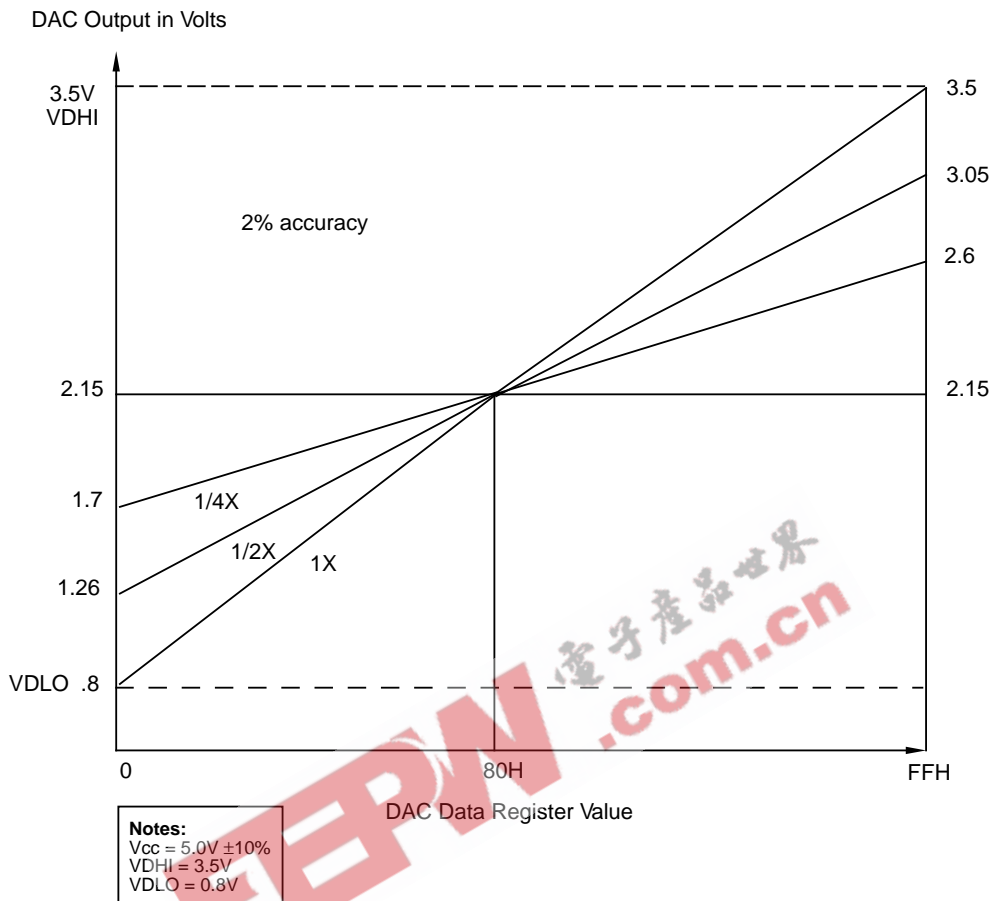

Figure 33. Gain Control on DAC

**Power-On Reset (POR).** A timer circuit clocked by a dedicated on-board RC oscillator or by the XTAL oscillator is used for the POR timer function. The POR time allows  $V_{CC}$  and the oscillator circuit to stabilize before instruction execution begins. The POR timer circuit is a one-shot timer triggered by one of three conditions:

- Power Fail to Power OK Status
- Stop-Mode Recovery (If D5 of SMR Register = 1)
- WDT Time-Out (Including from Stop Mode)

The POR time is  $T_{POR}$  minimum. Bit 5 of the STOP Mode Register determines whether the POR timer is bypassed after Stop-Mode Recovery (typical for external clock, and RC/LC oscillators with fast start up time).

**HALT.** Turns off the internal CPU clock but not the XTAL oscillation. The counter/timers and external interrupts IRQ0, IRQ1, and IRQ2 remain active. The device is recovered by interrupts, either externally or internally generated (a POR or a WDT time-out). An interrupt request must be executed (enabled) to exit HALT mode. After the interrupt service routine, the program continues from the instruction after the HALT. In case of a POR or a WDT time-out, program execution will restart at address 000CH.

**STOP.** This instruction turns off the internal clock and external crystal oscillation and reduces the standby current to 10  $\mu A$  (typical) or less. The STOP mode is terminated by a reset of either WDT time-out, POR, or Stop-Mode Recovery. This causes the processor to restart the application program at address 000CH.

In order to enter STOP (or HALT) mode, it is necessary to first flush the instruction pipeline to avoid suspending execution in mid-instruction. To do this, the user must execute a NOP (opcode = FFH) immediately before the appropriate sleep instruction, that is,

```

FF      NOP          ; clear the pipeline
6F      STOP         ; enter STOP mode
        or
FF      NOP          ; clear the pipeline
7F      HALT         ; enter HALT mode
    
```

**STOP-Mode Recovery (SMR) Register.** This register selects the clock divide value and determines the mode of STOP-Mode Recovery (Figure 34 and Figure 35). All bits are Write-Only, except bit 7, which is Read-Only. Bit 7 is a flag bit that is hardware set on the condition of STOP recovery and reset by a power-on cycle. Bit 6 controls whether a low level or a high level is required from the recovery source. Bit 5 controls the reset delay after recovery. Bits 2, 3, and 4, or the SMR Register, specify the source of the STOP-Mode Recovery signal. Bits 0 and 1 determine the timeout period of the WDT. The SMR Register is located in Bank F of the Expanded Register Group at address 0BH. When the Stop-Mode Recovery sources are selected in this register, then SMR2 Register bits D0,D1 must be set to 0.

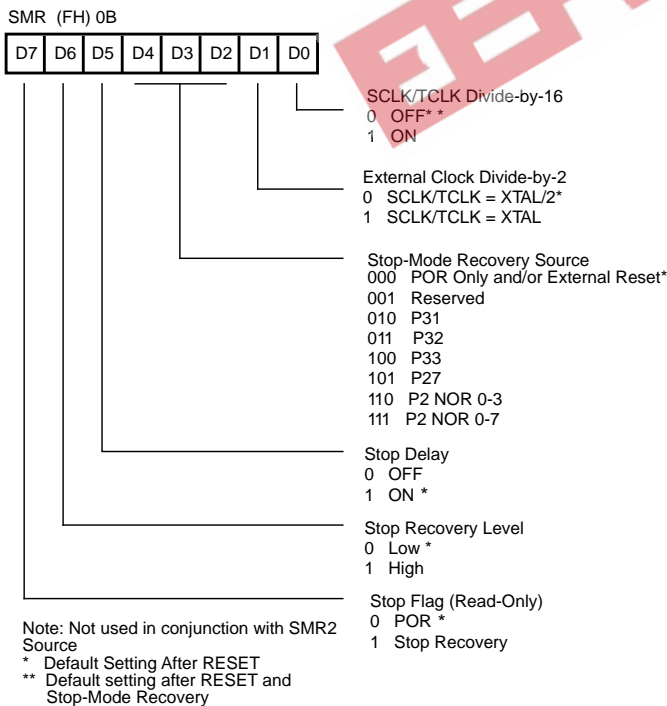

Figure 34. STOP-Mode Recovery Register (Write-Only Except Bit D7, Which Is Read-Only)

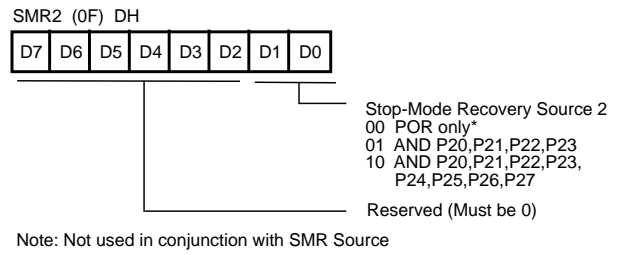

Figure 35. Stop-Mode Recovery Register 2 ([0F] DH: Write-Only)

**SCLK/TCLK Divide-by-16 Select (D0).** D0 of the SMR controls a divide-by-16 prescaler of SCLK/TCLK. The control selectively reduces device power consumption during normal processor execution (SCLK control) and/or HALT mode (where TCLK sources counter/timers and interrupt logic). This bit is reset to D0 = 0 after a Stop-Mode Recovery, WDT Timeout, and POR.

**External Clock Divide-by-Two (D1).** This bit can eliminate the oscillator divide-by-two circuitry. When this bit is 0, the System Clock (SCLK) and Timer Clock (TCLK) are equal to the external clock frequency divided by two. The SCLK/TCLK is equal to the external clock frequency when this bit is set (D1=1). Using this bit together with D7 of PCON further helps lower EMI (that is, D7 (PCON) = 0, D1 (SMR) = 1). The default setting is zero. Maximum external clock frequency is 4 MHz when SMR Bit D1 = 1 where SCLK/TCLK = XTAL.

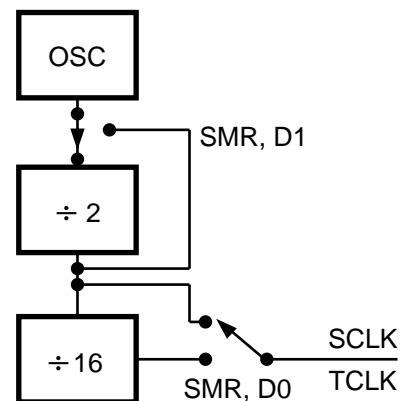

Figure 36. SCLK Circuit

## FUNCTIONAL DESCRIPTION (Continued)

### STOP-Mode Recovery Source (D2, D3, and D4).

These three bits of the SMR register specify the wake-up source of the STOP recovery (Figure 37 and Table 12). When the STOP-Mode Recovery Sources are selected in this register then SMR2 register bits D0,D1 must be set to zero. P33-P31 cannot wake up from Stop Mode if the input lines are configured as analog inputs to the Analog comparator or Analog-to-Digital Converter since the Analog Comparator's are powered down in Stop Mode.

**Note:** If the Port 2 pin is configured as an output, this output level will be read by the SMR circuitry.

**Table 12. STOP-Mode Recovery Source**

SMR:432			Operation Description of Action
D4	D3	D2	
0	0	0	POR and/or external reset recovery
0	0	1	Reserved
0	1	0	P31 transition (not in Analog Mode)
0	1	1	P32 transition (not in Analog Mode)
1	0	0	P33 transition (not in Analog Mode)
1	0	1	P27 transition
1	1	0	Logical NOR of P20 through P23
1	1	1	Logical NOR of P20 through P27

**STOP-Mode Recovery Delay Select (D5).** This bit, if High, enables the  $T_{POR}$  /RESET delay after Stop-Mode Recovery. The default configuration of this bit is "1". A POR or WDT reset will override the selection and cause the reset delay to occur.

**STOP-Mode Recovery Edge Select (D6).** A "1" in this bit position indicates that a high level on the output to the exclusive Or-Gate input from the selected recovery source wakes the Z86C83/C84 from STOP mode. A "0" indicates low-level recovery. The default is 0 on POR. This bit is used for either SMR or SMR2.

**Cold or Warm Start (D7).** This bit is set by the device upon entering STOP mode. A 0 in this bit (cold) indicates that the device resets by POR/WDT reset. A "1" in this bit (warm) indicates that the device awakens by a Stop-Mode Recovery source.

**Note:** A WDT reset out of Stop Mode will also set this bit to a "1."

**STOP-Mode Recovery Register 2 (SMR2).** This register contains additional Stop-Mode Recovery sources. When the Stop-Mode Recovery sources are selected in this register then SMR Register Bits D2, D3, and D4 must be 0.

**Table 13. Stop-Mode Recovery Source**

SMR:10		Operation Description of Action
D1	D0	
0	0	SMR2 disables source
0	1	Logical AND of P20 through P23
1	0	Logical AND of P20 through P27

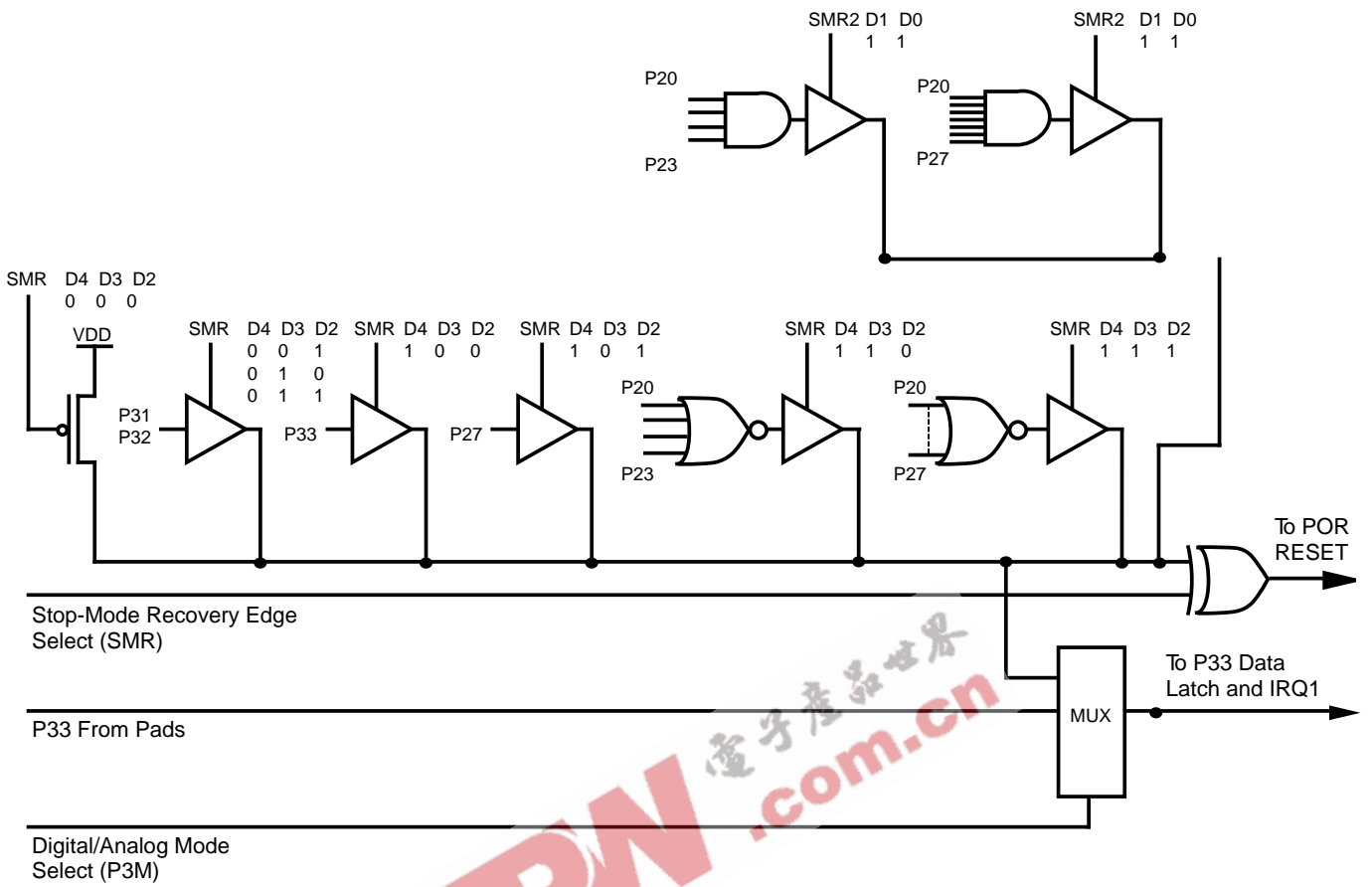

Figure 37. STOP-Mode Recovery Source

## FUNCTIONAL DESCRIPTION (Continued)

**Watch-Dog Timer Mode Register (WDTMR).** The WDT is a retriggerable one-shot timer that resets the Z8 if it reaches its terminal count. The WDT is initially enabled by executing the WDT instruction and refreshed on subsequent executions of the WDT instruction. The WDT circuit is driven by an on-board RC oscillator or external oscillator from the XTAL1 pin. The POR clock source is selected with bit 4 of the WDT register (Figure 38).

WDT instruction affects the Z (Zero), S (Sign), and V (Overflow) flags. The WDTMR must be written to within 64 internal system clocks. After that, the WDTMR is write protected.

**Note:** WDT time-out while in Stop-Mode will not reset SMR, PCON, WDTMR, P2M, P3M, Ports 2 and 3 Data Registers, but will cause the reset delay to occur.

The Power-On Reset (POR) clock source is selected with bit 4 of the WDTMR. Bits 0 and 1 control a tap circuit that determines the time-out period. Bit 2 determines whether the WDT is active during HALT and bit 3 determines WDT activity during STOP. If bits 3 and 4 of this register are both set to "1," the WDT is only driven by the external clock during STOP mode. This feature makes it possible to wake up from STOP mode from an internal source. Bits 5 through 7 of the WDTMR are reserved (Figure 39). This register is accessible only during the first 64 processor cycles (64 SCLKs) from the execution of the first instruction after Power-On-Reset, Watch-Dog Reset or a Stop-Mode Recovery. After this point, the register cannot be modified by any means, intentional or otherwise. The WDTMR cannot be read and is located in Bank F of the Expanded Register group at address location 0FH.

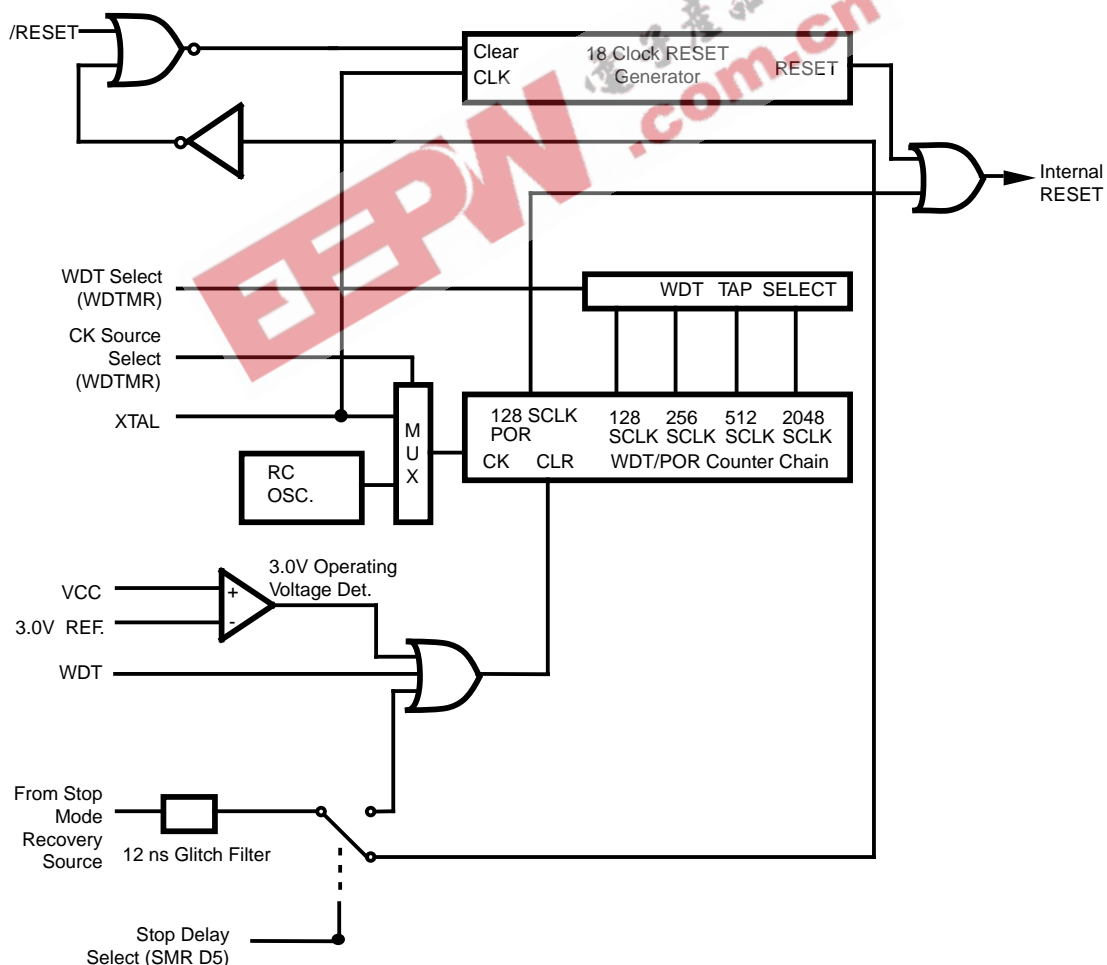
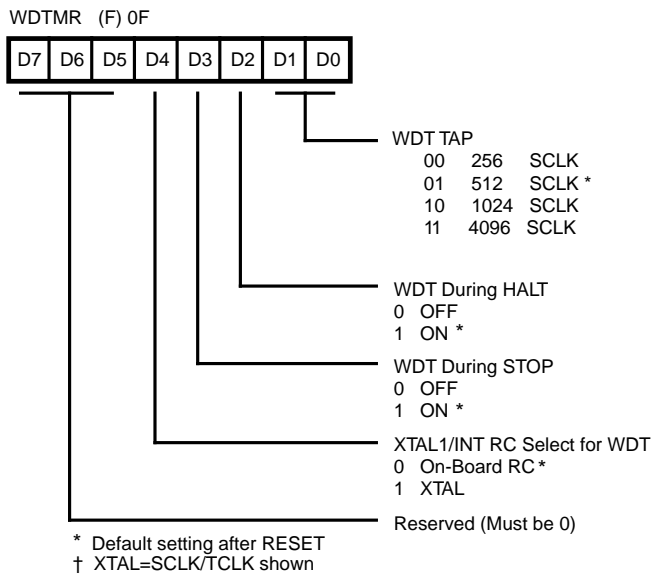

Figure 38. Resets and WDT



**Figure 39. Watch-Dog Timer Mode Register (Write Only)**

**WDT Time Select (D1, D0).** Selects the WDT time-out period. It is configured as shown in Table 14.

**Table 14. WDT Time Select (Min. @ 5.0V)**

D1	D0	Time-Out of Internal RC OSC	Time-Out of SCLK Clock
0	0	6.25 ms min	256 SCLK
0	1	12.5 ms min	512 SCLK*
1	0	25 ms min	1024 SCLK
1	1	100 ms min	4096 SCLK

**Notes:**

The default on a WDT initiated reset is 512 SCLK.  
The minimum time shown is for  $V_{cc}$  @ 5.0V.

**WDT During HALT (D2).** This bit determines whether or not the WDT is active during HALT mode. A "1" indicates active during HALT. The default is "1."

**Note:** If WDT is permanently selected (always ON mode), the WDT will continue to run even if set not to run in STOP or HALT Mode.

**WDT During STOP (D3).** This bit determines whether or not the WDT is active during STOP mode. Since XTAL clock is stopped during STOP mode, unless as specified below, the on-board RC has to be selected as the clock source to the POR counter. A "1" indicates active during STOP. The default is "1". If bits D3 and D4 are both set to "1," the WDT only, is driven by the external clock during STOP mode.

**Notes:**

1. If WDT is permanently selected (always ON mode), the WDT will continue to run even if set not to run in STOP or HALT Mode.
2. WDT instructions affect the Z (Zero), S (Sign), and V (Overflow) flags.

**On-Board, Power-On-Reset RC or External XTAL1 Oscillator Select (D4).** This bit determines which oscillator source is used to clock the internal POR and WDT counter chain. If the bit is a "1," the internal RC oscillator is bypassed and the POR and WDT clock source is driven from the external pin, XTAL1. The default configuration of this bit is 0, which selects the RC oscillator. If the XTAL1 pin is selected as the oscillator source for the WDT, during Stop Mode, the oscillator will be stopped and the WDT will not run. This is true even if the WDT is selected to run during Stop Mode.

**$V_{cc}$  Voltage Comparator.** An on-board Voltage Comparator checks that  $V_{cc}$  is at the required level to ensure correct operation of the device. RESET is globally driven if  $V_{cc}$  is below the specified voltage (typically 2.6V).

**ROM Protect.** ROM Protect is mask-programmable. It is selected by the customer at the time the ROM code is submitted.

**ROM Mask Selectable Options**

There are six ROM mask options that must be selected at the time the ROM mask is ordered (ROM code submitted).

**Table 15. ROM Mask Selectable Options**

Option	Selection
Permanent WDT	Yes/No
Port0 Pull-Ups	Yes/No
Port0 Auto Latches	Yes/No
ROM Protect	Yes/No
RAM Protect	Yes/No

## EXPANDED REGISTER FILE CONTROL REGISTERS (0C)

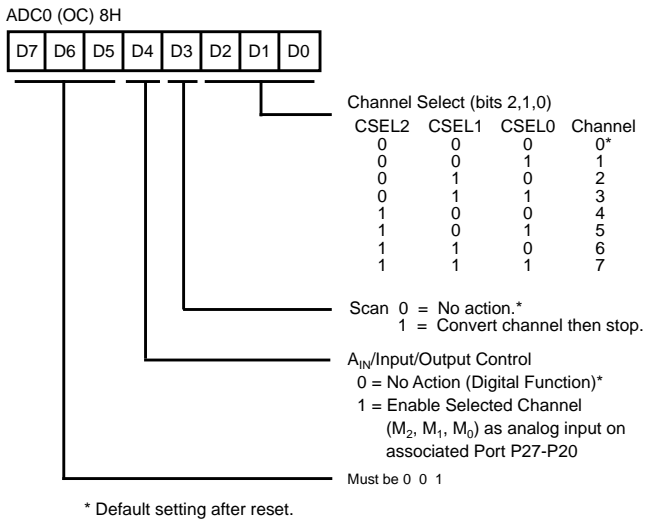

Figure 40. ADC Control Register 0 (Read/Write)

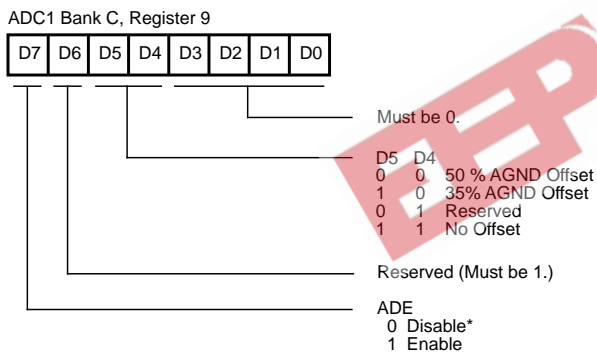

Figure 41. ADC Control Register 1 (Read/Write)

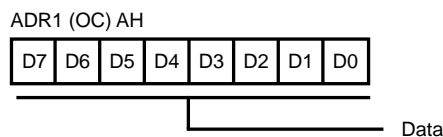

Figure 42. AD Result Register (Read Only)

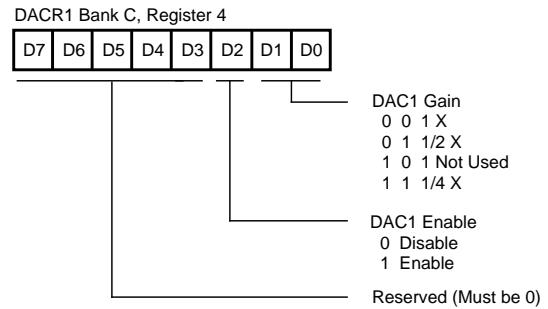

Figure 43. D/A 1 Control Register

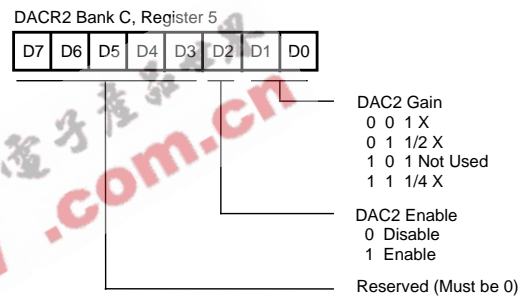

Figure 44. D/A 2 Control Register

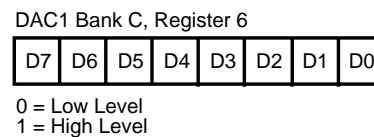

Figure 45. D/A 1 Data Register

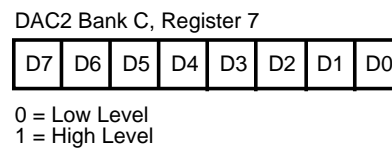
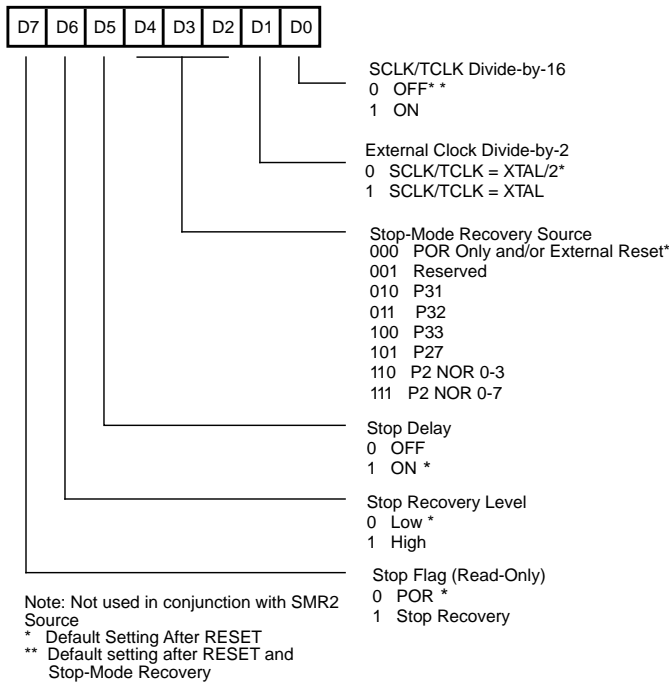

Figure 46. D/A 2 Data Register



## EXPANDED REGISTER FILE CONTROL REGISTERS



**Figure 47. Stop-Mode Recovery Register (Write-Only, except Bit 7 which is Read-Only)**

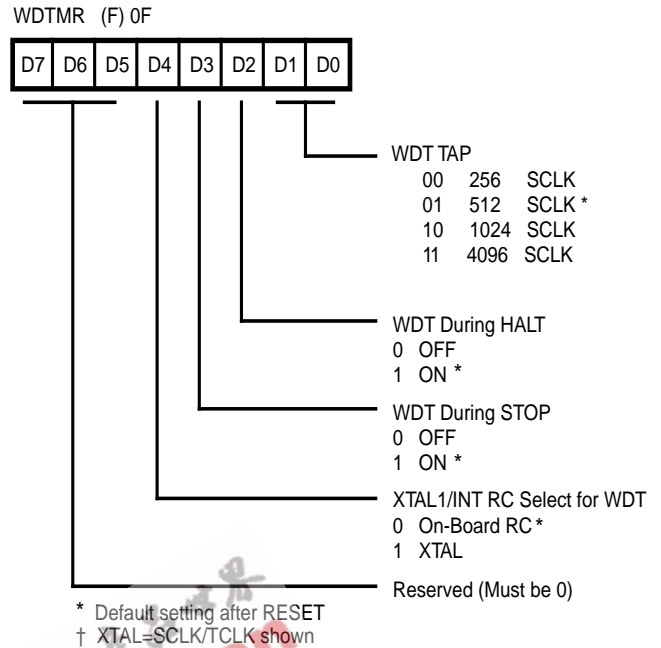

**Figure 49. Watch-Dog Timer Mode Register (Write-Only)**

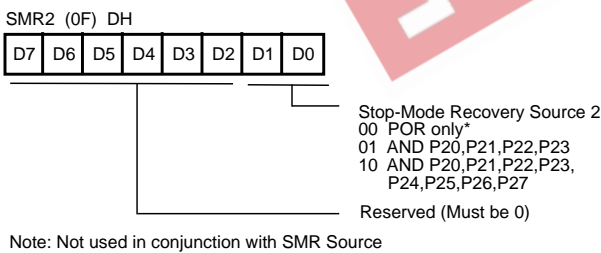

**Figure 48. Watch-Dog Timer Mode Register 2**

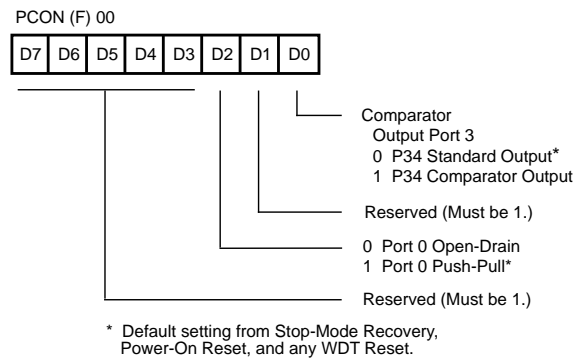

**Figure 50. Port Configuration Register (PCON) (Write-Only)**



## Z8 CONTROL REGISTERS

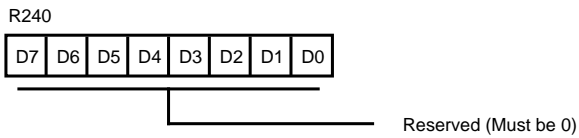

Figure 51. Reserved

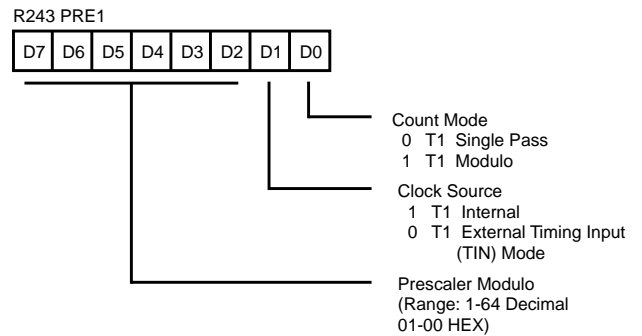

Figure 54. Prescaler 1 Register (F3<sub>H</sub>: Write-Only)

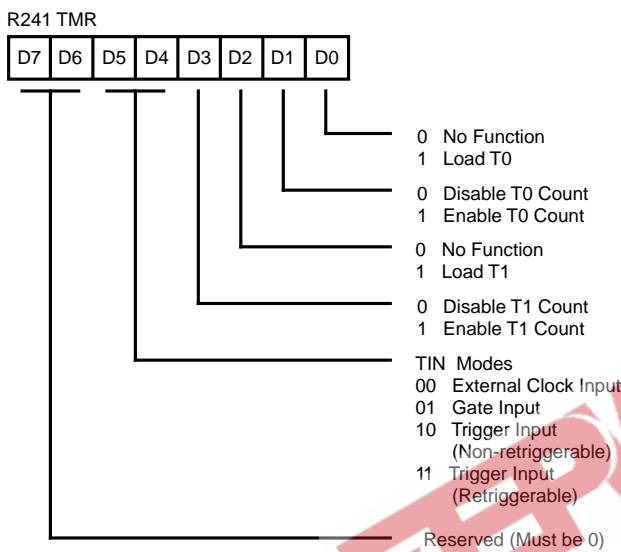

Figure 52. Timer Mode Register (F1<sub>H</sub>: Read/Write)

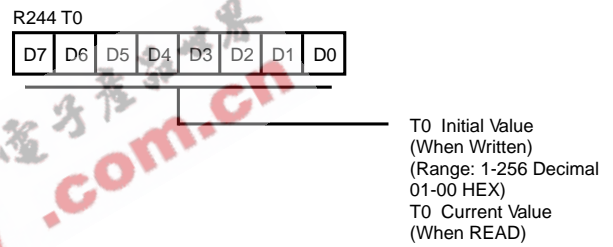

Figure 55. Counter/Timer 0 Register (F4<sub>H</sub>: Read/Write)

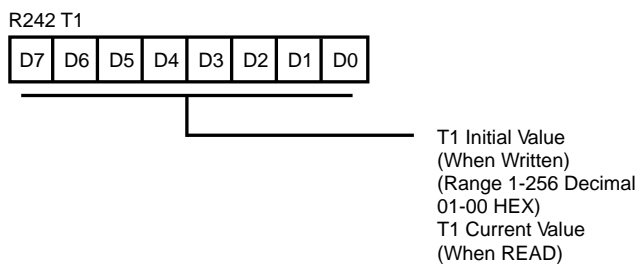

Figure 53. Counter/Timer 1 Register (F2<sub>H</sub>: Read/Write)

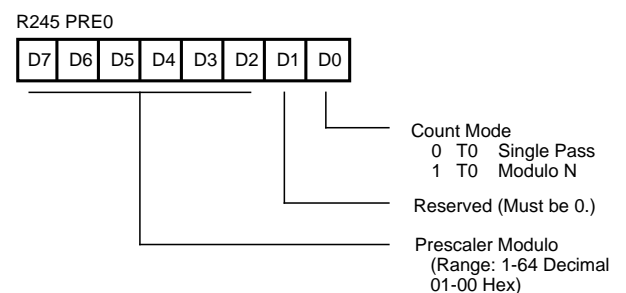

Figure 56. Prescaler 0 Register (F5<sub>H</sub>: Write-Only)

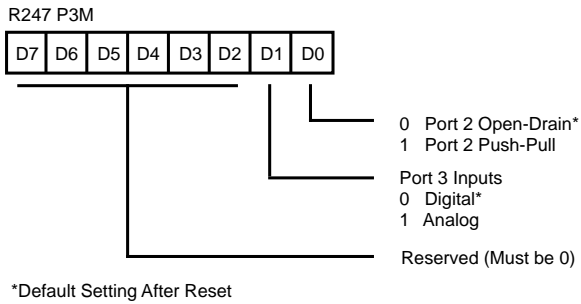

Figure 57. Port 3 Mode Register (F7<sub>H</sub>: Write-Only)

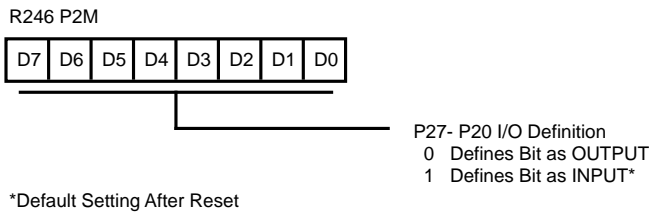

Figure 58. Port 2 Mode Register (F6<sub>H</sub>: Write-Only)

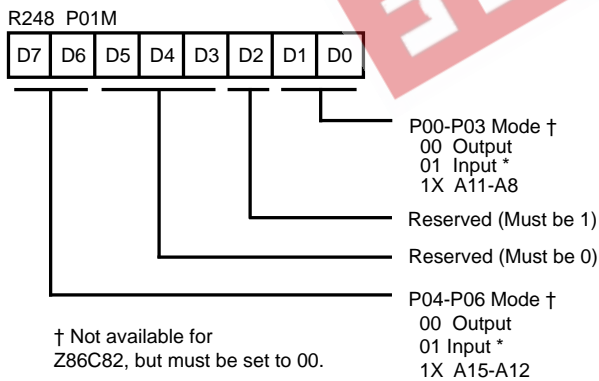

Figure 59. Port 0 and 1 Mode Register (F8<sub>H</sub>: Write-Only)

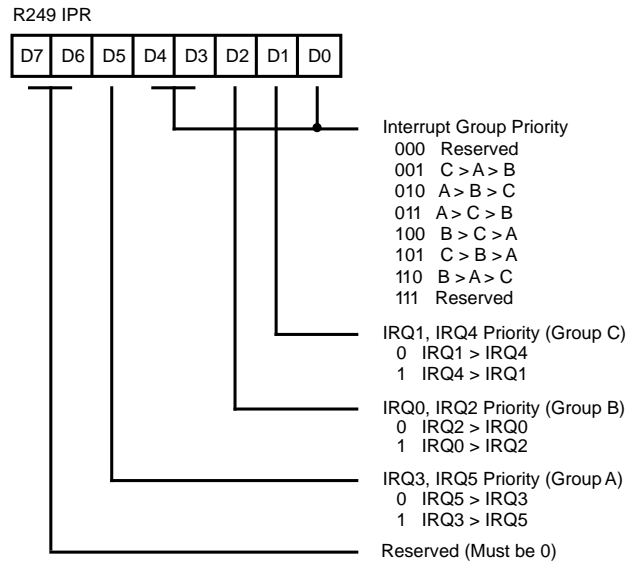

Figure 60. Interrupt Priority Register (F9<sub>H</sub>: Write-Only)

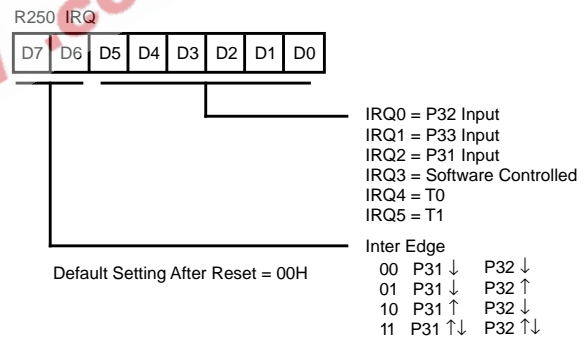

Figure 61. Interrupt Request Register (FA<sub>H</sub>: Read/Write)

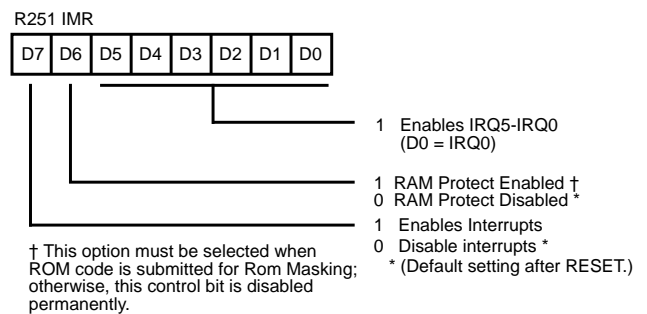
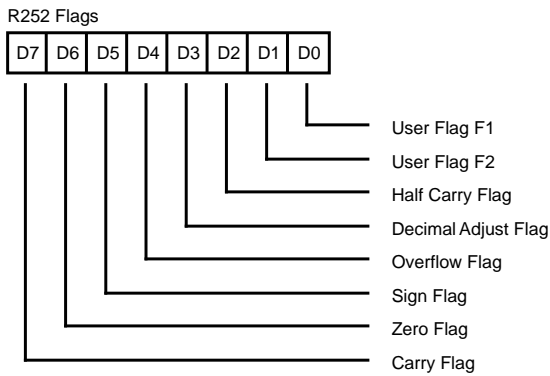
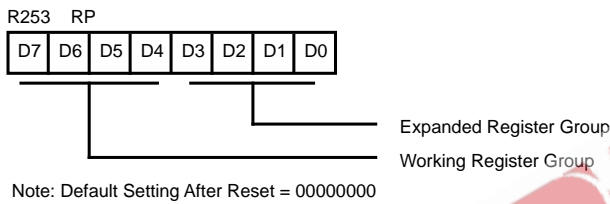

Figure 62. Interrupt Mask Register (FB<sub>H</sub>: Read/Write)

## Z8 CONTROL REGISTERS (Continued)



**Figure 63. Flag Register (F<sub>CH</sub>: Read/Write)**



**Figure 64. Register Pointer (F<sub>DH</sub>: Read/Write)**

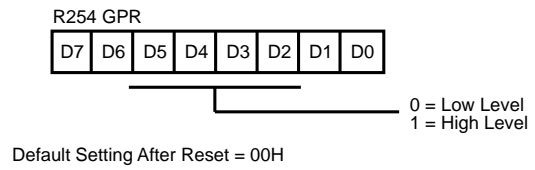

**Figure 65. General-Purpose Register (F<sub>EH</sub>: Read/Write)**

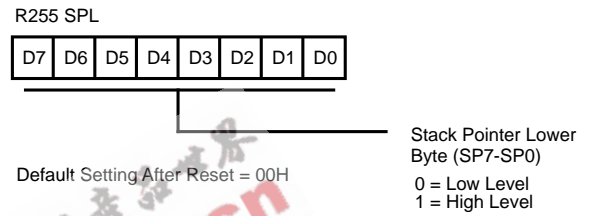

**Figure 66. Stack Pointer (F<sub>FH</sub>: Read/Write)**

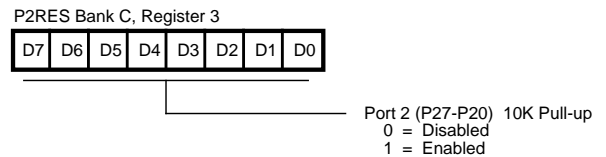

**Figure 67. Port 2 Pull-up Register**

PACKAGE INFORMATION

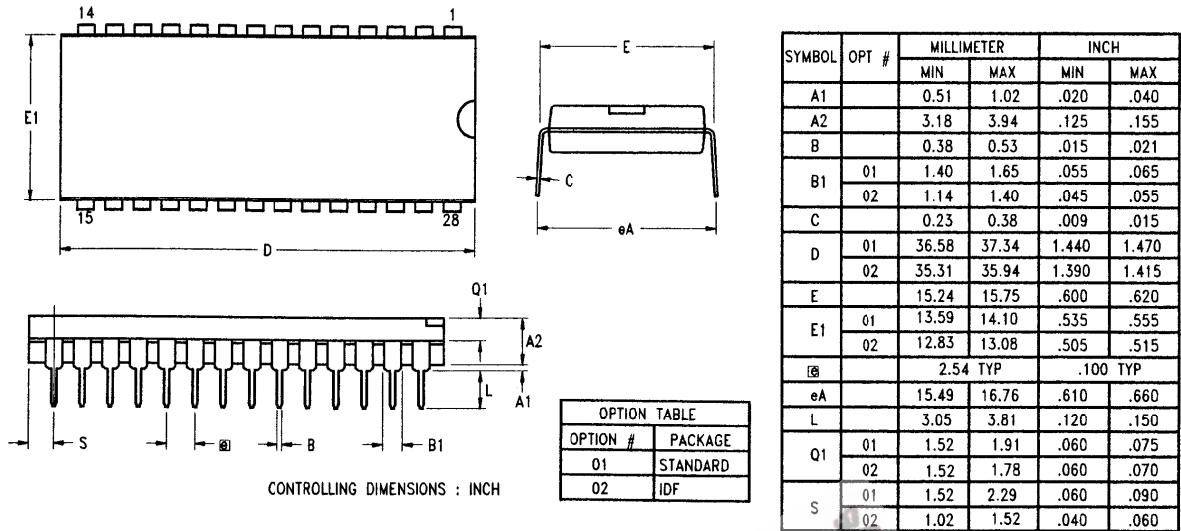

Figure 68. 28-Pin DIP Package Diagram

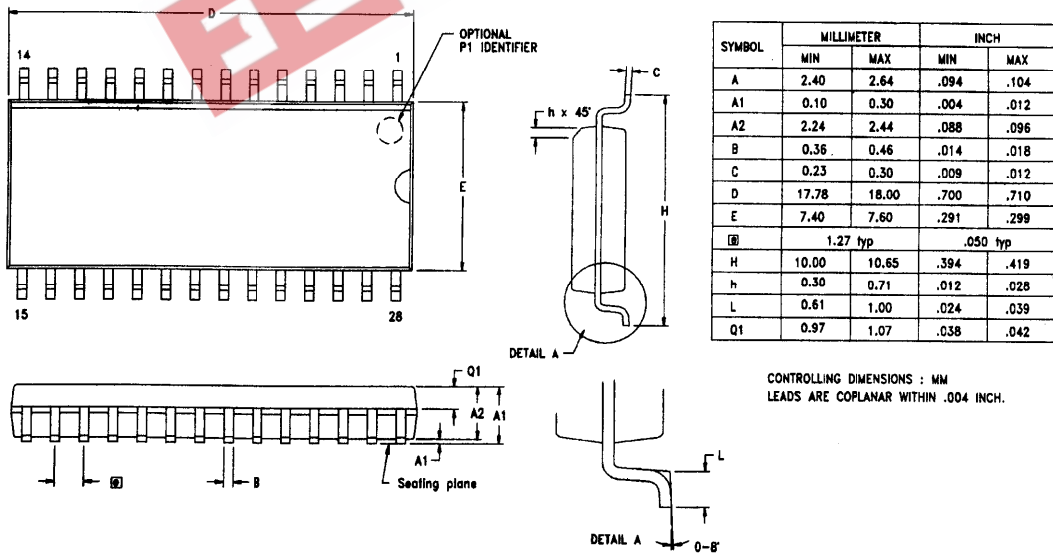

Figure 69. 28-Pin SOIC Package Diagram

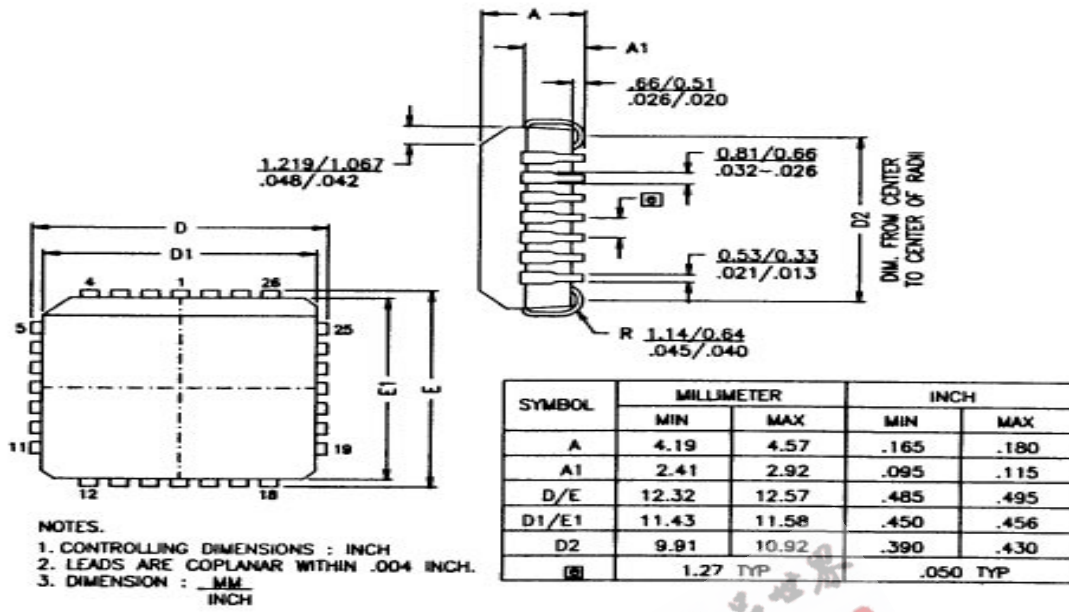

Figure 70. 28-Pin PLCC Package Diagram

## ORDERING INFORMATION

### Z86C83

16 MHz

28-Pin DIP	28-Pin SOIC	28-Pin PLCC
Z86C8316PSC	Z86C8316SSC	Z86C8316VSC
Z86C8316PEC	Z86C8316SEC	Z86C8316VEC

### Z86C84

16 MHz

28-Pin DIP	28-Pin SOIC	28-Pin PLCC
Z86C8416PSC	Z86C8416SSC	Z86C8416VSC
Z86C8416PEC	Z86C8416SEC	Z86C8416VEC

For fast results, contact your local Zilog sales office for assistance in ordering the part desired.

## CODES

### Package

P = Plastic DIP  
S = Plastic SOIC

### Temperature

S = 0° C to +70° C  
E = -40° C to +105° C

### Speed

16 = 16 MHz

### Environmental

C = Plastic Standard

Example:

Z 86C83 16 P S C is a Z86C83, 16 MHz, DIP, 0° to +70°C, Plastic Standard Flow

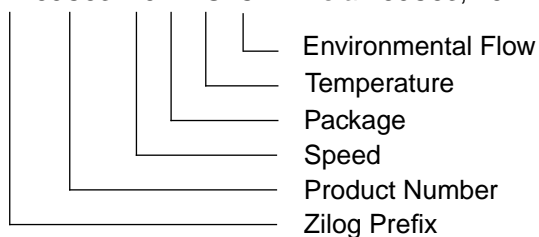

EEPW 电子产品世界 .com.cn