

# Low Noise Amplifiers

**NEW!**  
**ZQLSC-SERIES**

50Ω 600 to 2400 MHz



**BLUE CELL™**  
CASE STYLE: GZ1067

## Features

- high reliability balanced design
- noise figure, 0.6 dB typ.
- built-in alarm monitoring
- TTL alarm output, green/red alarm status LED
- voltage regulated/protected DC input

## Applications

- low noise receiver
- digital cellular base stations
- TDMA, CDMA, GSM
- DCS, PCS, UMTS

## Electrical Specifications (T<sub>AMB</sub>= 25°C)

MODEL NO.	FREQ. (MHz) f <sub>L</sub> - f <sub>U</sub>	GAIN (dB)				NOISE FIGURE (dB)		MAXIMUM POWER (dBm)			INTER-CEPT POINT IP3 dBm Typ.	VSWR (:1)		DC POWER		CASE STYLE	PRICE \$ QTY. (1-9)
		Typ.		Flatness		Typ.	Max.	Output (1 dB Comp.) Typ.	Input (no damage) Min.	Max.		In	Out	Volt <sup>1</sup> Typ.	Max. Current (mA)		
		Min.	Max.	Typ.	Max.												
ZQLSC-1100	600-824	20	17.5	±.75	±1.0	0.6	1.1	18.5	16	10	32.5	2.0	2.0	24	185	GZ1067	295.00
	824-849	19	17.5	±.15	±0.3	0.55	0.7	19	16	10	34	1.7	1.7	24	185		
	880-915	18.5	17	±0.2	±0.4	0.55	0.8	19	16	10	35	1.8	1.8	24	185		
	915-1100	17.5	15	±0.9	±1.2	0.6	1.0	19	16	10	35.5	1.8	1.8	24	185		
ZQLSC-2400	1400-1850	17	13.5	±1.0	±2.5	0.8	1.15	19	17	10	37	1.7	1.6	24	185	GZ1067	295.00
	1850-2000	15.6	12.5	±0.5	±1.0	0.9	1.25	20.5	17	10	35	1.5	1.6	24	185		
	2000-2400	13.2	10.5	±1.5	±2.0	1.1	1.65	20	17	10	34	1.6	1.9	24	185		

## Maximum Ratings

Operating Temperature	-40°C to 80°C case -40°C to 60°C ambient
Storage Temperature	-55°C to 100°C
DC Voltage	+18V min., 36V max.

<sup>1</sup> Other voltages available in the 6.5 to 60V range, please contact factory.

## Alarm Functions

Normal:	TTL low output (0 to 0.8V), green LED
Alarm:	TTL high output (4 to 5V), red LED
DC & alarm connector:	9-pin male D-sub

## Pin Connections

RF input	J1
RF output	J2
DC power input	5
TTL alarm output	1
Ground to test alarm, normally open	7*, 9*
No connection	3, 6, 8
Ground	2, 4

\*Grounding Pin 7 will sink 75mA of current through Pin 7 creating a high-current alarm condition inside the amplifiers. A red LED and TTL high output will occur. Pin 7 floats at +4.3V typ. when open.

\*Grounding Pin 9 will sink 2mA of current through pin 9 and creating a low-current alarm condition inside the amplifier. A red LED and TTL high output will occur. Pin 9 floats at about +0.6V typ. when open.

## Outline Drawing

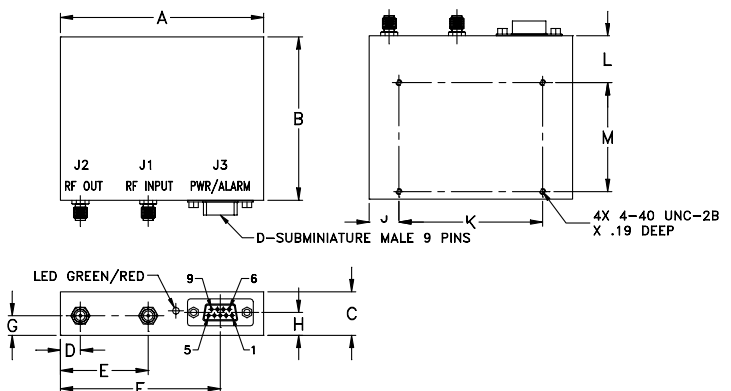

## Outline Dimensions (inch/mm)

A	B	C	D	E	F	G	H	J	K	L	M	wt.
3.75	3.00	.80	.37	1.62	2.95	.36	.42	.55	2.650	.86	2.000	grams
95.25	76.20	20.32	9.40	41.15	74.93	9.14	10.67	13.97	67.31	21.84	50.80	260

ZQLSC-1100

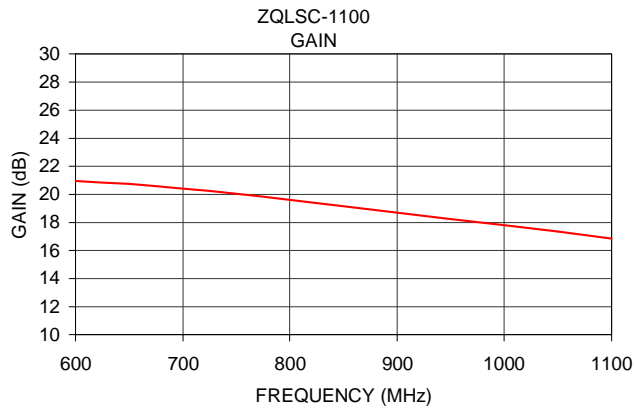

ZQLSC-2400

