

FEATURES

- Single Chip DVD Decoder Solution for DVD Player Designs
- Highest Certification for Dolby Digital Audio
- DTS and MPEG5.1 passthrough via S/PDIF output
- Patented Single 16Mbit SDRAM for Full Operation
- Picture Zoom Functionality
- Embedded Karaoke Capability
- 3D Audio Post-processing Capability
- Reverse Trickplays Including Smooth Reverse
- Dolby Digital, Pro-Logic, MPEG Audio Capability
- VCD/CD compatible
- Embedded 40 MIPS DSP
- 160 pin TQFP Package
- Less than 1W power consumption
- Integrated OSD processor

DESCRIPTION

The ZR36710 DVD decoder is targeted for third generation DVD products. The highly integrated ZR36710 is ideal for developing a high-quality DVD player. The product is based on Zoran's strong history in the DVD marketplace. Through the Standard-Plus™ design methodology, functions such as reverse trickplays and zoom capability are provided. The ZR36710, through its SiliconSoftware™ feature, has the capability to integrate key functions such as 3D audio and Karaoke.

Highest Quality Audio

The internal architecture of the ZR36710, which is based on Zoran's field proven audio DSP, enables the development of a DVD system which meets the highest quality audio standards. The ZR36710 DVD decoder includes an embedded 20-bit high-performance audio DSP which enables the Vaddis architecture to perform at audiophile quality for its audio output signals. Other solutions, which use 16-bit audio technology cannot attain this status. The high performance capability of the embedded audio DSP enables the implementation of additional audio processing algorithms such as Karaoke and 3D audio.

DVD Support

The ZR36710 handles all aspects of DVD decoding according to the DVD Specification. The single-chip device performs DVD authentication/decryption, demux and parsing, MPEG-2 or MPEG-1 video decode, sub-picture decode, highlight processing, audio/video synchronization, Dolby Digital decoding, Pro-Logic decoding and 3D audio. In addition, an on-screen display unit offers overlaid graphics and a closed caption modulator provides support for line 21 data.

At the heart of the Vaddis ZR36710 are two powerful processing units: the Demux/Video Processor (DVP unit) and the Audio Decode Processor (ADP unit), a user programmable, 40 MIPS, DSP engine. The DVP unit operates from downloadable micro-code to parse the bitstream and route data to the appropriate units. The Picture Reconstruction Unit completes the MPEG-2 or MPEG-1 video decode and passes the image to the Video Post Processing (VPU unit). The VPU unit performs vertical/horizontal scaling, decodes and blends Sub-picture data, inserts Line 21 (close caption) text and overlays On Screen Display data.

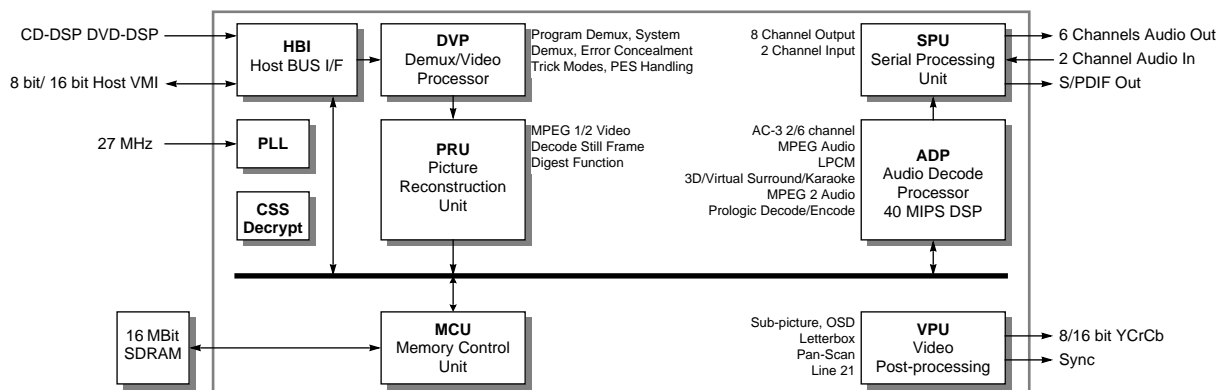

Figure 1. Vaddis III Block Diagram

KEY FEATURES

DTS and MPEG Multi-channel Passthrough

The ZR36710 incorporates the capability to provide a digital output of DTS or MPEG 5.1 through the S/PDIF output. This digital data is transmitted for use by an audio receiver for multi-channel decoding.

Karaoke

Karaoke is a popular feature for the Asia market. Karaoke features can be implemented in the ZR36710, thus eliminating the need for an external karaoke processor. Voice Canceling is a feature to eliminate the singer's voice on a CD by comparing left and right channels and filtering out the vocal content, allowing you to sing along. The echo function provides the effect of singing in a large auditorium and slightly modifies the singer's voice to enhance the sound. Key Control adjusts the pitch of the music by quarter tones to allow the pitch of the music to be shifted to match the pitch of the singer's voice.

Reverse Trickplay

Further adding to the video capability of the Vaddis, the ZR36710 incorporates reverse trickplay functionality to provide seamless reverse functions in addition to the standard trickplay

functions common to DVD players. The reverse trickplay provides smooth transitions for a viewer to single step or fast reverse through scenes.

Patented SDRAM Memory Usage

The ZR36710 uses a patented and proprietary implementation for DVD decoding with a single 16 Mbit SDRAM. This dramatically reduces the number of the chips and the size of the required memory, thereby lowering the power consumption and the overall cost of a DVD system.

A Solution for the Consumer DVD Player Market.

The Vaddis III ZR36710 can be used in a DVD Player design. High quality audio is a key feature of DVD and the Vaddis supports the highest quality Dolby Digital possible for a DVD player design. In addition, the functions of reverse trickplay and zoom capability enhance the video playback. Support for DTS passthrough enables the playback of video titles that are encoded with DTS audio tracks. Support for MPEG5.1 provides the same capability. In summary, the ZR36710 is ideally suited for developing a high quality, feature rich third generation DVD player design.

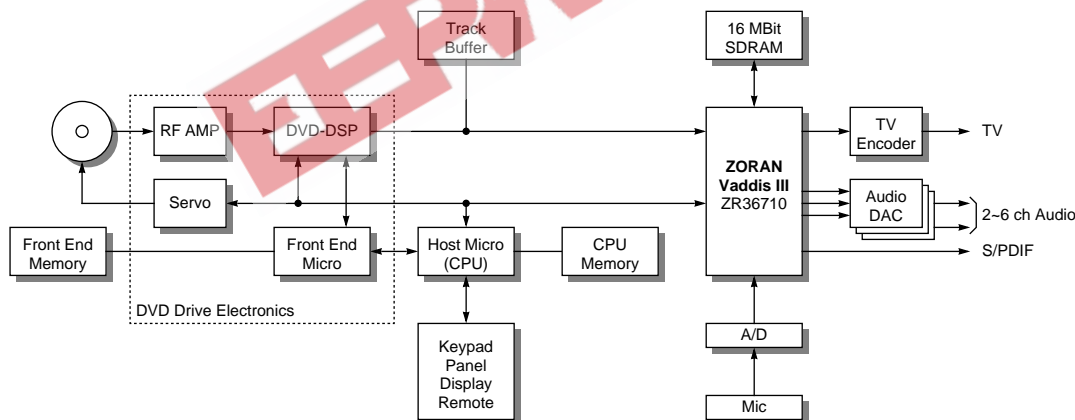

Figure 2. DVD Player Application Using the Vaddis III ZR36710

Vaddis is a trademark of Zoran Corporation. All other trademarks are property of their respective companies.

For More Information:

■ U.S. Headquarters

Zoran Corporation
3112 Scott Blvd.
Santa Clara, CA 95054 USA
Telephone: +1 (408) 919-4111
FAX: +1 (408) 919-4122

■ Israel Operations

Zoran Microelectronics, Ltd.
Advanced Technology Center
P.O. Box 2495
Haifa, 31024 Israel
Telephone: +972 4 8545-777
FAX: +972 4 8551-550

■ Japan

Zoran Japan Office
2-2-8 Roppongi, Minato-ku
Tokyo 106-0032, Japan
Telephone: +03-5574-7081
FAX: +03-5574-7156

■ China

Zoran China Office
Suite 1706, Grand Skylight Hotel
68 Central Shennan Rd.
Shenzhen, Guangdong, 518041, PR China
Telephone: +86 755-3363225
FAX: +86 755-3363256