

# ZMD31012

## RBic<sup>2</sup>Lite™

Two Low-cost Sensor Signal Conditioners  
ZMD31010 Chips in One Package

PRELIMINARY



## Features two ZMD31010

- Separate digital compensation of sensor offset, sensitivity, temperature coefficient and non-linearity
- Accommodates differential sensor signal spans from 1.2mV/V to 60mV/V for two inputs
- Dual ZACwire™ one-wire interface
- Internal temperature compensation reference via bandgap PTAT\*
- Optional sequential output of both temperature and bridge readings two ZACwire™ digital output
- Output options: ratiometric analog voltage, absolute analog voltage, digital one-wire-interface
- Supply voltage 2.7V to 5.5V, with external JFET 5.5V to 30V
- Current consumption 2mA
- Operation temperature -50°C to +150°C
- Fast response time: 1ms
- High voltage protection up to 30V with external JFET
- Chopper stabilized true differential ADC
- Buffered and chopper stabilize output DAC

\*Proportional to absolute temperature

- ZMD31010 Development Kit can be used
- Support for industrial mass calibration will be available
- Quick circuit customization possible for large production volumes

## Application Circuit

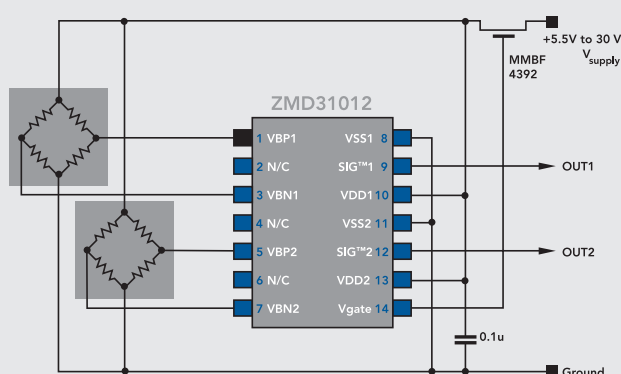

## Benefits

The ZMD31012 combines the benefits of two single ZMD31010.

- No external trimming components required
- PC-controlled configuration and calibration via one-wire interface – simple, low cost
- High accuracy ( $\pm 0.1\%$  FSO @ -25°C to 85°C;  $\pm 0.25\%$  FSO @ -40°C to 125°C)
- Single pass calibration – quick and precise

Due to the two independent channels the ZMD31012 provides a perfect fit for the following selected samples:

- Applications that require redundancy
- Measurement of differential pressure
- Flow Sensors

## Brief Description

The ZMD31012 consists of two ZMD31010 dies in a standard SSOP14 packages. ZMD31012 is a CMOS integrated circuit, which enables easy and precise calibration of resistive bridge sensors via EEPROM. When mated to a resistive bridge sensor, it will digitally correct offset and gain with the option to correct offset and gain coefficients and linearity over temperature. A second compensation can be enabled for temperature coefficients of gain or offset or bridge linearity. ZMD31012 communicates via ZMD's ZACwire™ serial interface to the host computer and is easily mass calibrated in a Windows® environment.

Once calibrated, the output SIG™ pin can provide selectable 0V to 1V, rail-to-rail ratiometric analog output, or digital serial output of bridge data with optional temperature data.

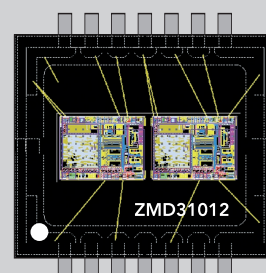

## Application Examples

### Appliances



- Filter Check
- Refrigerant
- Pressure Monitoring

### Industrial



- Process Control
- Dataloggers

### Automotive



- Airflow
- Differential Pressure
- Process Control
- Redundancy

### Consumer/Medical



- Blood Pressure Meters
- PDAs

## Ordering Code

Example:

ZMD31012BIF-T

ZMD Product Sales Name

Design Revision

- A = first design revision
- B = second design revision
- etc.

Target Application Area/  
Usual Operating Temperature Range\*

- I = Industrial (-40°C to +125°C)
- E = Extended automotive (-50°C to +150°C)

Delivery Form\*\*

- T = delivery in tube
- R = delivery in tape on reel
- S = special (e.g. sample box)

Die/Package Options

- B = tested dice on unsawn wafer
- C = tested dice on frame
- D = tested dice in waffle pack
- F = finished parts in plastic package
- G1 = finished parts in "green" plastic package (lead-free terminals – pure Sn)

\* only for serial parts; engineering samples don't have this character

\*\* only for finished parts in plastic package

Engineering samples can be marked with the additional characters "ES".  
Not all possible product versions are available. Please ask ZMD sales if and when a certain product version is available.

### For further information:

#### ZMD AG

Grenzstrasse 28  
01109 Dresden  
Germany  
Tel +49.351.8822.366  
Fax +49.351.8822.337  
sales@zmd.de

#### ZMD America, Inc.

201 Old Country Road, Suite 204  
Melville, NY 11747  
USA  
Tel +1.631.549.2666  
Fax +1.631.549.2882  
sales@zmda.com

#### ZMD Far East

1F, No. 14, Lane 268, Sec. 1 Guangfu Rd.  
HsinChu City 300  
Taiwan  
Tel +886.3.563.1388  
Fax +886.3.563.6385  
sales@zmd.de